

The Airtech 3AVN Series closed-coupled liquid ring vacuum pumps are an attractive option for many vacuum applications, offering low power requirements, compact design, and reliability.

The single-stage design incorporates valves, port cylinder, and a mechanical seal, facilitating capacity between 55 CFM and 125 CFM

- Up to 5 times the delivery of liquid as compared to conventional liquid ring vacuum pumps
- Stable suction capacity even when liquid is delivered
- No need for pre-separation
- Easy installation
- Regulated power consumption ensures minimal operating costs
- Extremely low noise levels
- Patented hydraulic and assembly system

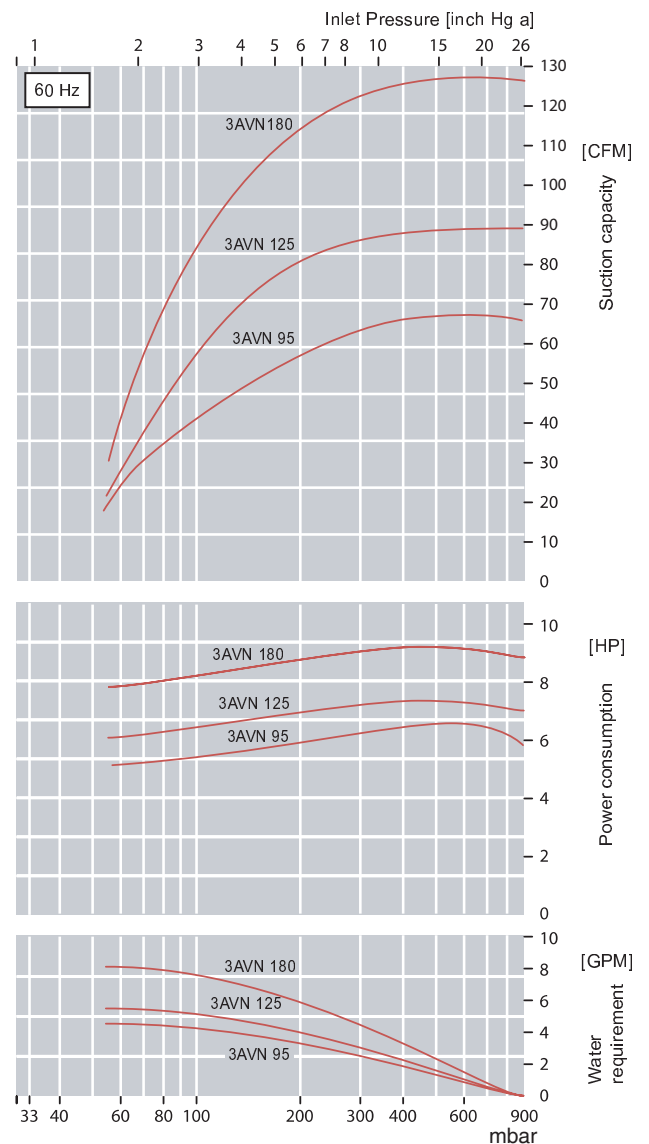

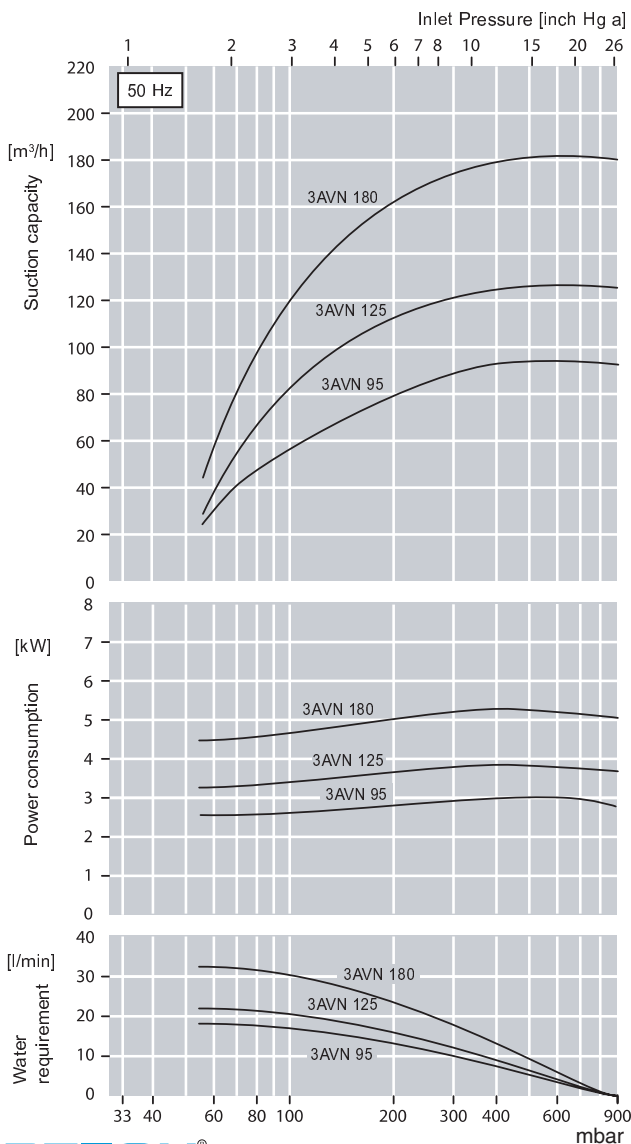
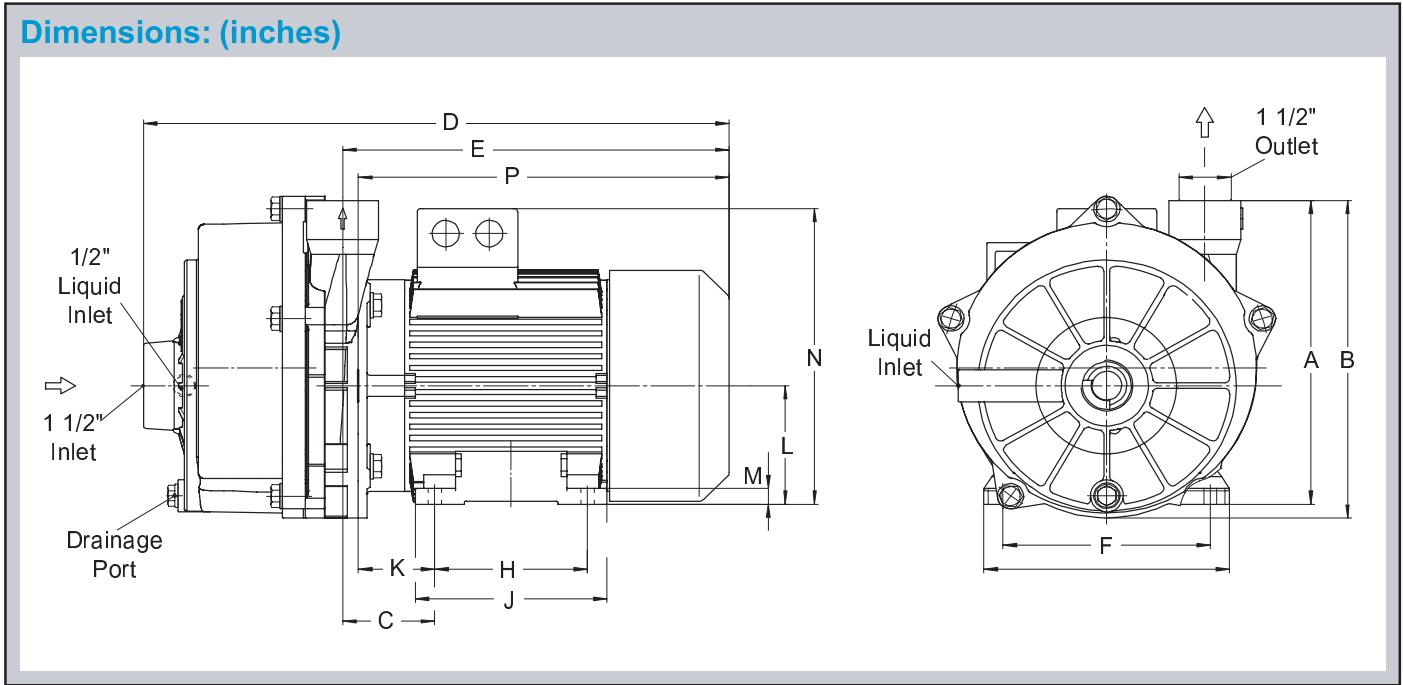

Model	A	B	C	D	E	F	G	H	J	K	L	M	N	P
3AVN 95	10.8	11.8	3.1	18.4	12.5	6.3	7.7	5.5	6.9	2.4	3.9	.5	8.9	12.0
3AVN 125	11.3	11.8	3.3	20.3	13.2	7.5	8.8	5.5	6.9	2.8	4.4	.6	11.0	12.5
3AVN 180	12.1	11.8	4.9	25.9	15.4	8.5	10.1	5.5	8.6	4.3	5.2	.7	12.6	16.7

Performance Data - Vacuum (60 Hz)

Model	Rated H.P.	CFM	Voltage Range	Max Amps	Seal Water (GPM)	Weight (lbs.)
3AVN 95	6.2	65	230/460	16/8	4	134
3AVN 125	8.9	90	230/460	22.5/11	5	159
3AVN 180	11	125	230/460	27/13.5	8	214

The characteristics are applicable for compression of 20° C (68° F) dry air from inlet pressure to atmospheric pressure (1013 mbar / 30 inch Hg a) for nominal speed and drive with three phase motors. Ring liquid is water at 15° C (59° F). The tolerance of the suction capacity is -10% and of the power consumption is +10%. With different operating conditions characteristic curves change (e.g. differing gas operating liquid conditions, conveying of additional liquids and/or pumping of gas-steam mixtures).