

REV	DESCRIPTION	ECN #	CHG BY	DATE	APP'D
A	CONVERTED TO 3D/UPDATED PART NUMBER, WAS CSL	16955	EZR	08/20/19	TAS

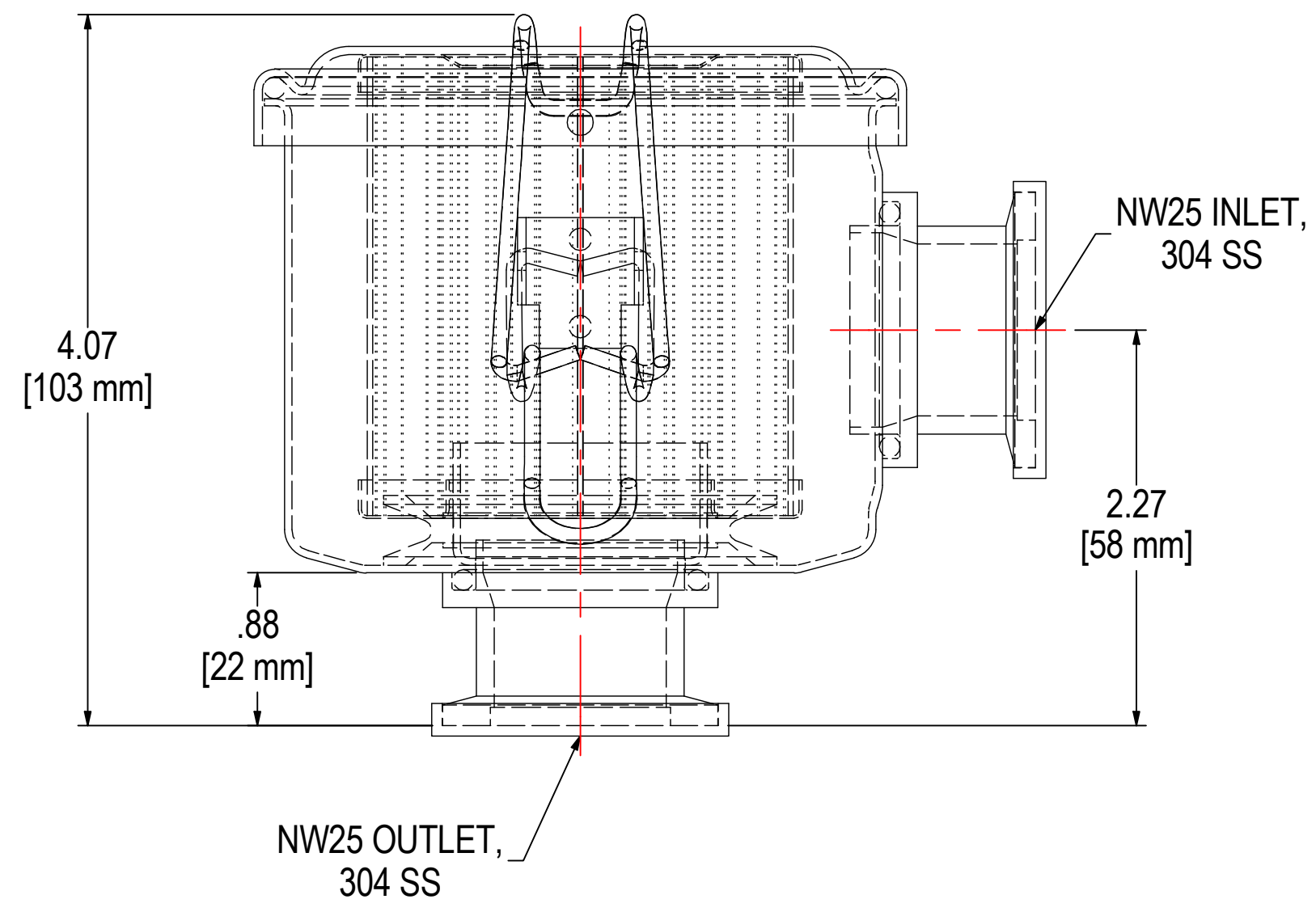
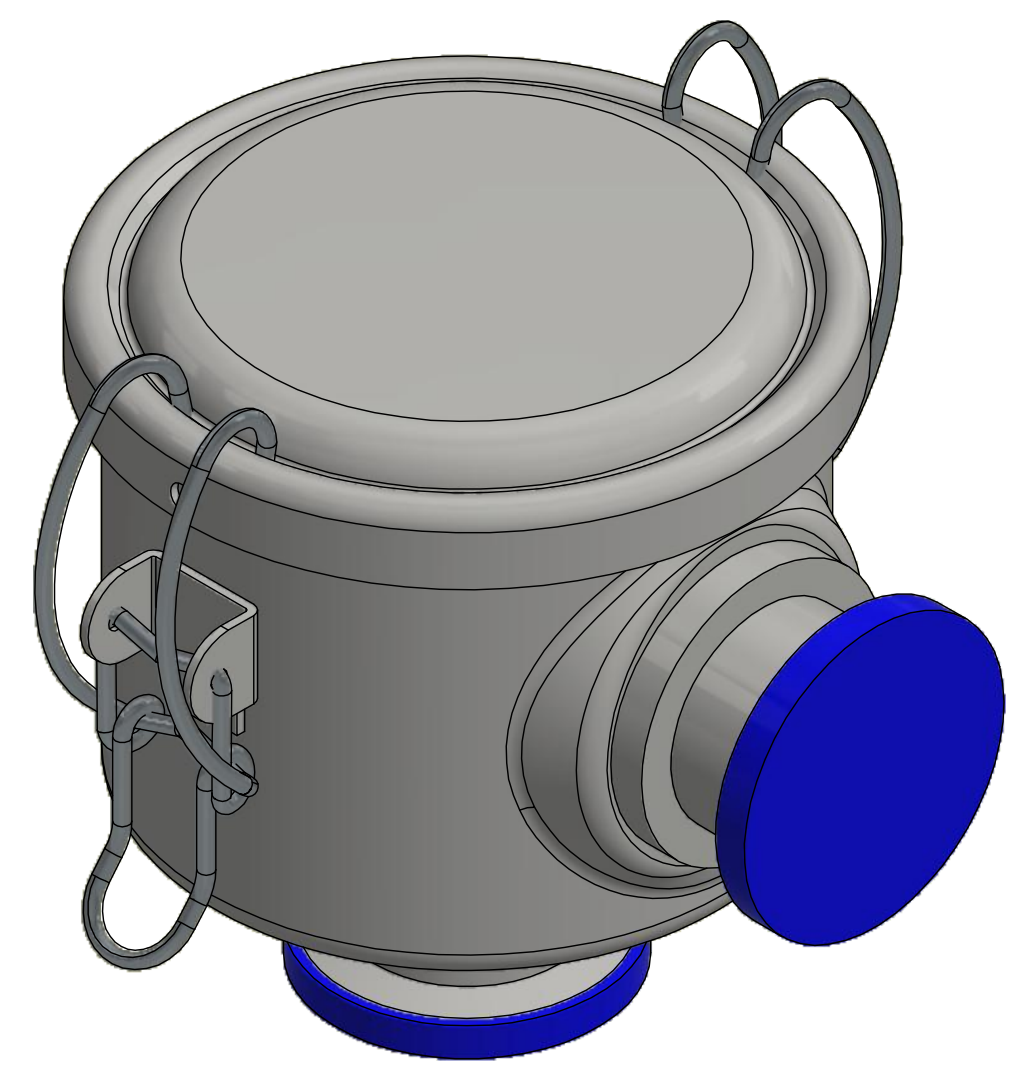
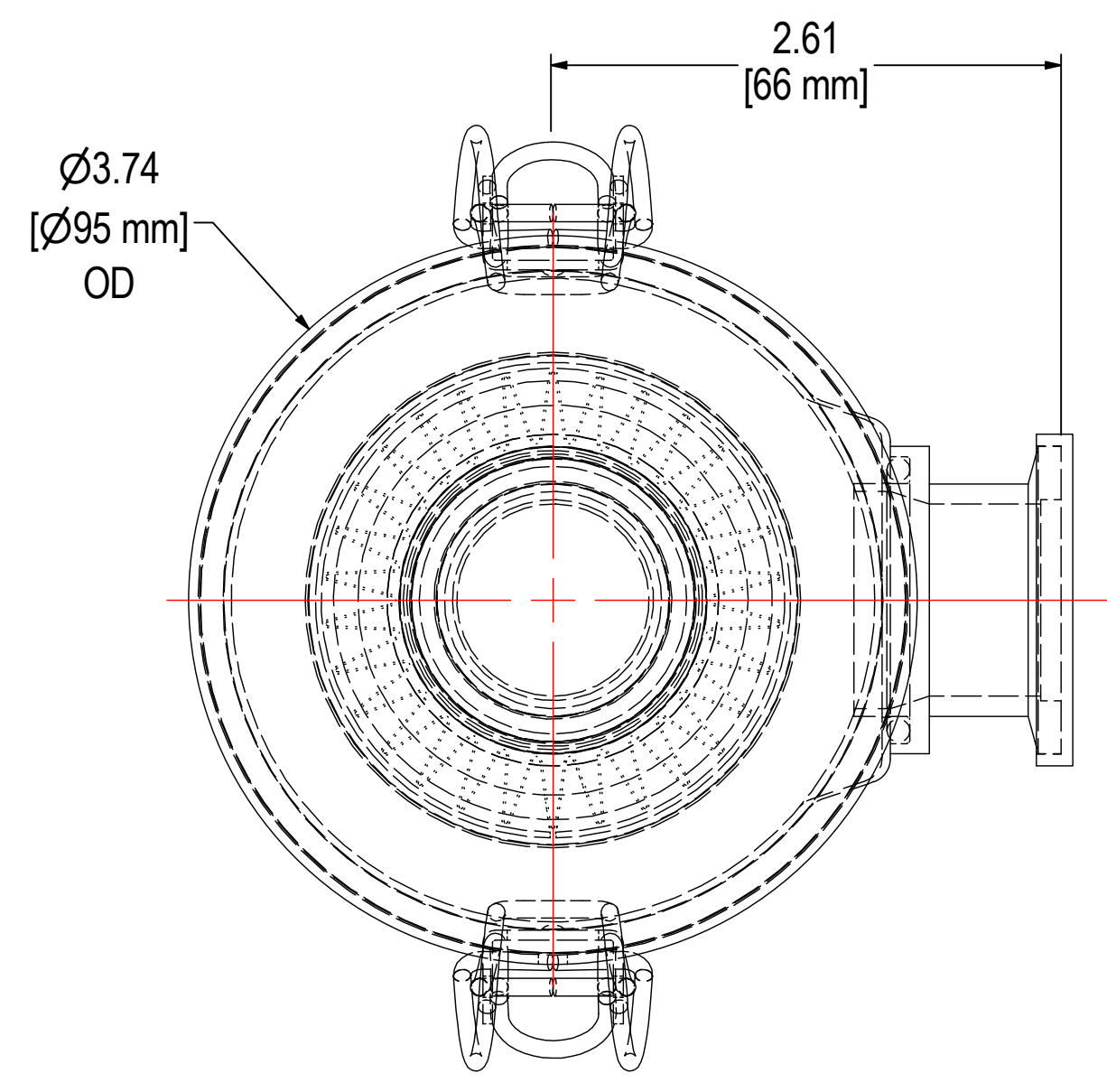

**NOTES & SPECIFICATIONS:**

1. FLANGES TO BE PROTECTED DURING PRODUCTION & SHIPMENT.
2. UNIT TO BE HELIUM LEAK TESTED TO  $1 \times 10^{-5}$  mbar L/s.

ELEMENT SPECS		
PART NUMBER	825	
MATERIAL	Polyester	
FLOW RATE	25 CFM	42 m <sup>3</sup> /hr
SURFACE AREA	0.4 ft <sup>2</sup>	0.0 m <sup>2</sup>
I.D.	1.50"	38mm
O.D.	2.50"	64mm
HEIGHT	2.69"	68mm

<b>MODEL #:</b> WL-825-NW25EN	<b>MATERIAL:</b> CARBON STEEL	<b>FINISH:</b> ELECTROLESS NICKEL	<b>SHEET:</b> 1 OF 1
<b>MODEL NUMBER:</b> WL-825-NW25EN			<b>REVISION:</b> A
<b>DESCRIPTION:</b> WL-825-NW25EN, ELECTROLESS NICKEL			
<b>PROJECT:</b> SD19010	<b>DRAWN BY:</b> EZR	<b>APPROVED BY:</b> CRW	<b>DATE:</b> 2/1/2013
	<b>DATE:</b> 2/1/2013	<b>DATE:</b> 2/1/2013	

**SOLBERG**  
Filtration • Separation • Silencing  
630.773.1363 • www.solbergmfg.com

THE INFORMATION CONTAINED HEREIN IS CONFIDENTIAL AND THE PROPERTY OF SOLBERG MANUFACTURING INC. AND IT IS FURNISHED TO YOU WITH THE EXPRESS UNDERSTANDING THAT IT WILL NOT BE REPRODUCED, COPIED IN ANY MANNER, LOANED OR OTHERWISE TRANSFERRED TO OTHERS ENTIRELY OR IN PART, NOR USED FOR ANY PURPOSE OTHER THAN FOR WHICH IT WAS FURNISHED. IT WILL BE RETURNED UPON REQUEST TO SOLBERG MANUFACTURING INC. THE ABOVE RESTRICTION IS IN ADDITION TO, AND DOES NOT IN ANY WAY ALTER, ANY OTHER RESTRICTIONS WHICH MAY APPLY TO THE INFORMATION CONTAINED HEREIN.

**TOLERANCES**  
DIMENSIONS ARE FOR REFERENCE ONLY. ALL DIMENSIONS ARE SUBJECT TO CHANGE UPON PRODUCTION.  
UNLESS OTHERWISE SPECIFIED:  
-DIMENSIONS ARE IN INCHES  
-REF: APPROXIMATE DIMENSIONS, NO TOLERANCES APPLY  
-FINISH: BREAK EDGES TO .005-.020 RADIUS/CHAMFER