

REV	DESCRIPTION	ECN #	CHG BY	DATE	APP'D
A	UPDATED STANDARD DRAWING LAYOUT	17661	TAS	11/11/19	NAD

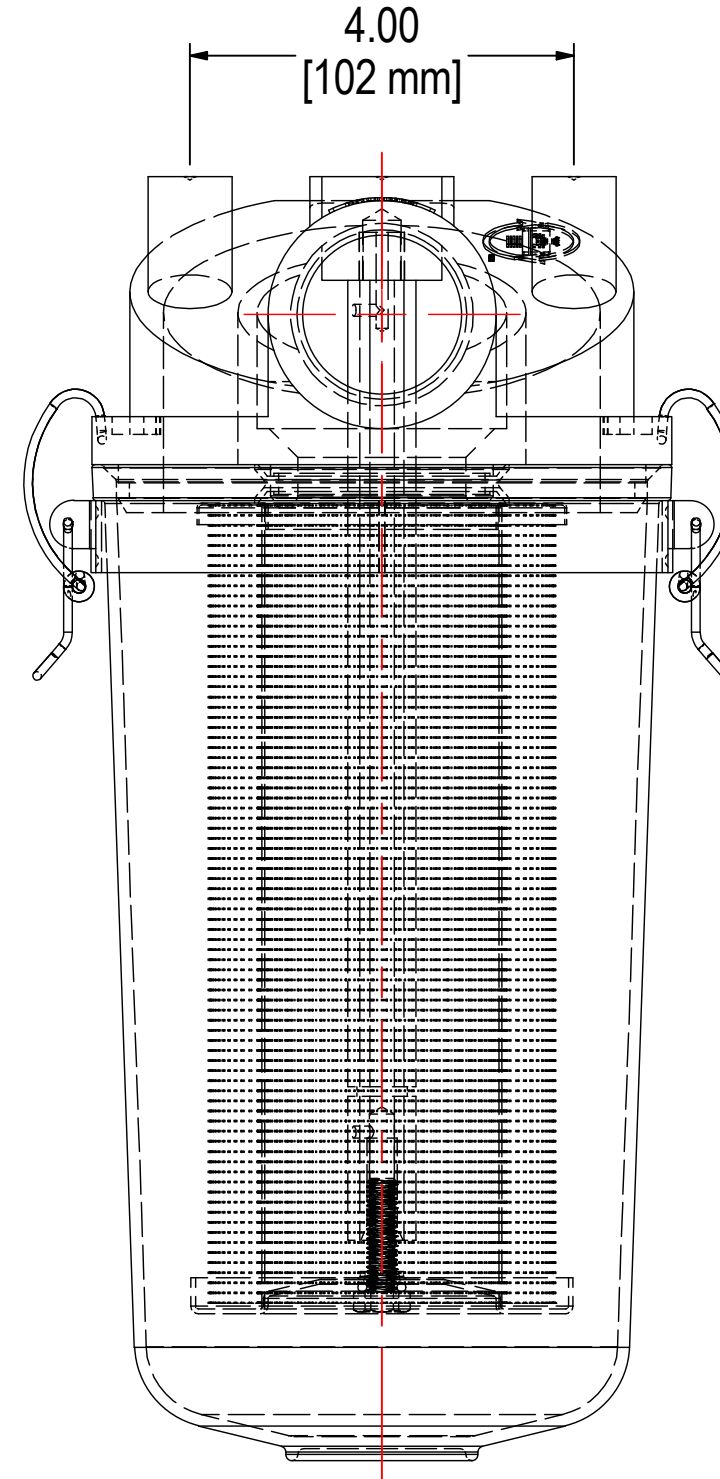
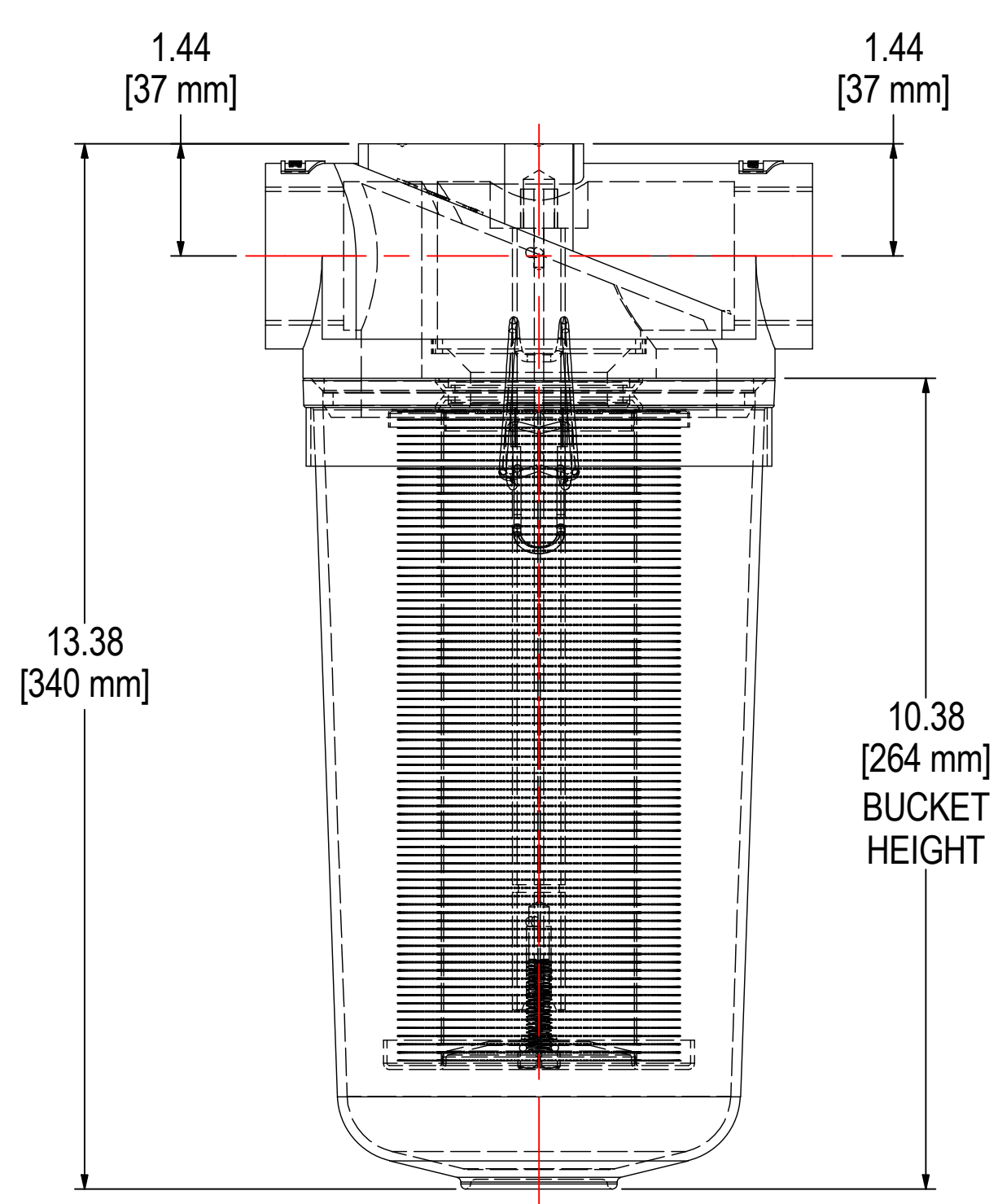
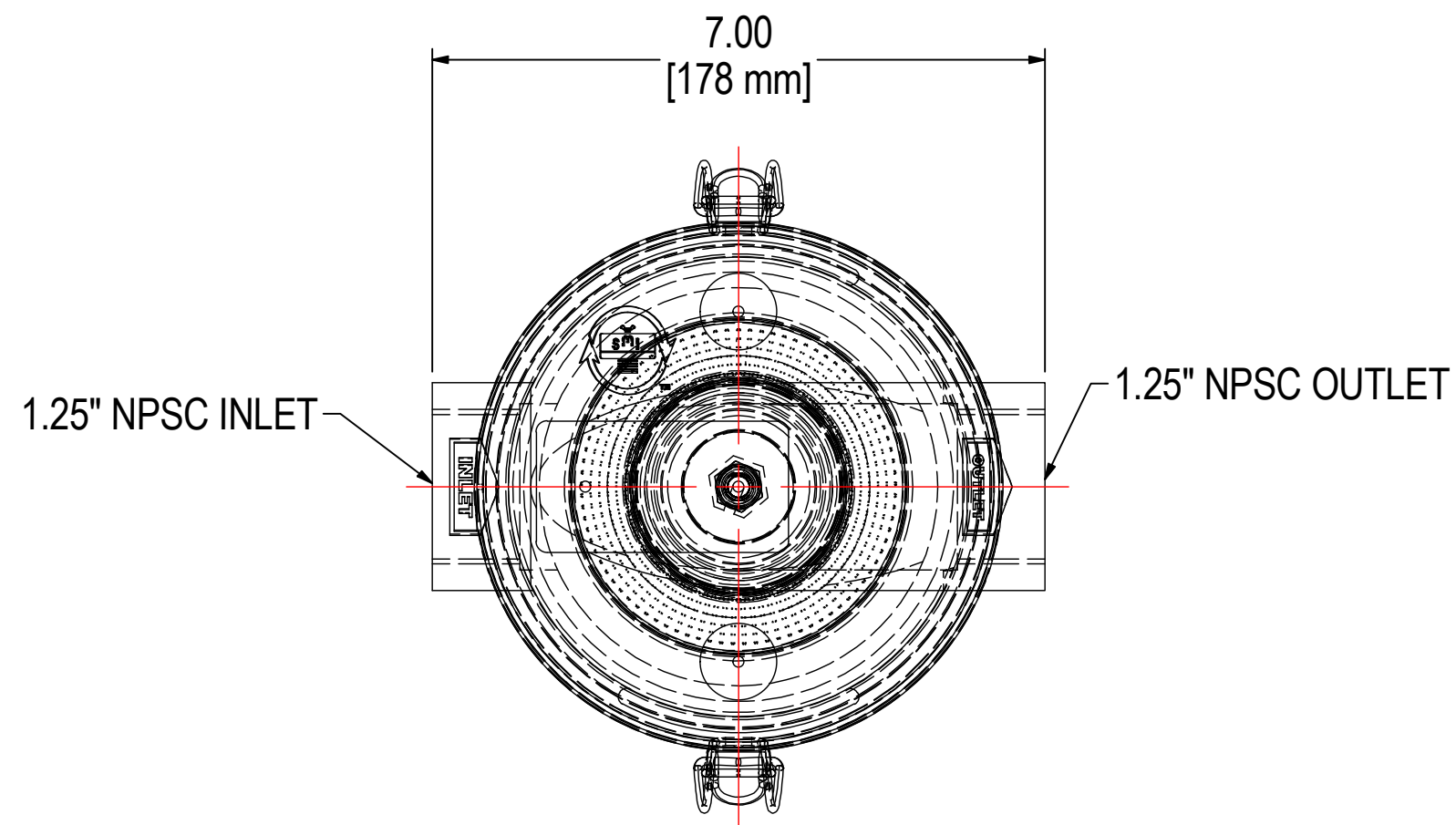

ELEMENT SPECS		
PART NUMBER	897	
MATERIAL	POLYESTER	
FLOW RATE	80 CFM	136 m <sup>3</sup> /hr
SURFACE AREA	2.1 ft <sup>2</sup>	0.2 m <sup>2</sup>
I.D.	2.38"	60mm
O.D.	3.98"	101mm
HEIGHT	8.44"	214mm

MODEL #: ST-897-125C	MATERIAL: CAST ALUM/POLYCARB	FINISH: NONE	SHEET: 1 OF 1
MODEL NUMBER: ST-897-125C	DESCRIPTION: ST-897-125C, CLEAR BUCKET		
PROJECT:	DRAWN BY: JCB	APPROVED BY: M.C.	REV: A
	DATE: 3/14/2012	DATE: 3/14/2012	

THE INFORMATION CONTAINED HEREIN IS CONFIDENTIAL AND THE PROPERTY OF SOLBERG MANUFACTURING INC. AND IT IS FURNISHED TO YOU WITH THE EXPRESS UNDERSTANDING THAT IT WILL NOT BE REPRODUCED, COPIED IN ANY MANNER, LOANED OR OTHERWISE TRANSFERRED TO OTHERS ENTIRELY OR IN PART, NOR USED FOR ANY PURPOSE OTHER THAN FOR WHICH IT WAS FURNISHED. IT WILL BE RETURNED UPON REQUEST TO SOLBERG MANUFACTURING INC. THE ABOVE RESTRICTION IS IN ADDITION TO, AND DOES NOT IN ANY WAY ALTER, ANY OTHER RESTRICTIONS WHICH MAY APPLY TO THE INFORMATION CONTAINED HEREIN.

**TOLERANCES**  
 DIMENSIONS ARE FOR REFERENCE ONLY. ALL DIMENSIONS ARE SUBJECT TO CHANGE UPON PRODUCTION.  
 UNLESS OTHERWISE SPECIFIED:  
 -DIMENSIONS ARE IN INCHES  
 -REF: APPROXIMATE DIMENSIONS, NO TOLERANCES APPLY  
 -FINISH: BREAK EDGES TO .005-.020 RADIUS/CHAMFER

**SOLBERG**  
 Filtration • Separation • Silencing  
 630.773.1363 • www.solbergmfg.com