

Specifications

Port Sizes	1/4", 3/8"
Thread Styles	NPT, BSPT, BSPP
Flow Capacity	20 SCFM @ 100 PSI
Filter Capacity	1.0 micron & larger
Differential Pressure	< 5.0 PSID at rated flow
Max. Temp./Pressure (Aluminum Bowl)	175 °F/200 PSIG
Max. Temp./Pressure (Polycarbonate Bowl)	125 °F/150 PSIG
Approx. Weight (lb.)	2.0
ISO Class	2 Particulate

For higher pressure applications, consult factory. Units equipped with differential pressure indicator have max. temperature and pressure of 125 °F and 150 PSIG, regardless of bowl material.



Water
Dirt
Oil
Oil Vapor
Odor

Replacement Parts & Accessories

Description	Part Number
A Replacement Element	3P-020
B Differential Pressure Indicator	N32-W1-DPI
B Blanking Cap (Cover for units without indicator)	N32-95-020
C Bowl Assembly: Metal Bowl, Manual Petcock Drain, O-ring	N32-95-178
C Bowl Assembly: Metal Bowl, Automatic Float Drain, O-ring	N32-95-950
D Bowl Assembly: Poly Bowl, Manual Petcock Drain, O-ring*	N32-15-159
D Bowl Assembly: Poly Bowl, Automatic Float Drain, O-ring*	N32-15-160
E Manual Petcock Drain	N32-95-182
F Automatic Float Drain	N32-95-973
G Bowl O-ring	N32-95-009
Mounting Bracket (Optional)	GPA-95-016

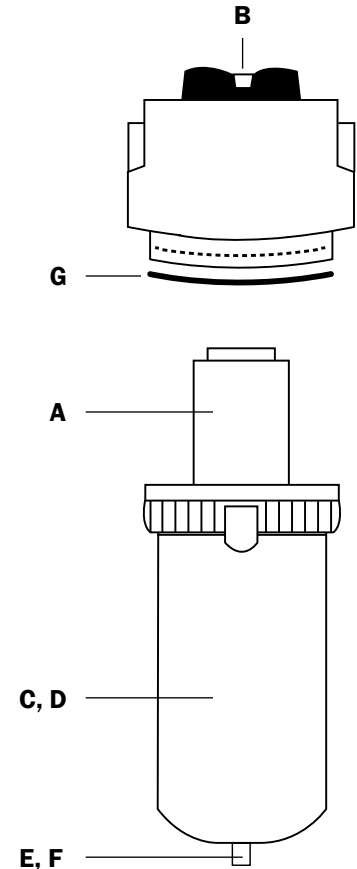

Order Guide

Drain Type	Port Size	Model Number		Dimensions (in.)		
		Metal Bowl	Poly Bowl	Height**	Width	Depth
Manual	1/4"	3P-020-M02-P	3P-020-P02-P	7.2	3.0	2.7
	3/8"	3P-020-M03-P	3P-020-P03-P	7.2	3.0	2.7
Automatic	1/4"	3P-020-M02-F	3P-020-P02-F	7.4	3.0	2.7
	3/8"	3P-020-M03-F	3P-020-P03-F	7.4	3.0	2.7

*Poly bowls come with metal bowl guard

**To add an indicator, add "i" to end of model number (Indicator adds about 1" to height)

Specifications

Port Sizes	1/4", 3/8", 1/2"
Thread Styles	NPT, BSPT, BSPP
Flow Capacity	35/60 SCFM @ 100 PSI
Filter Capacity	1.0 micron & larger
Differential Pressure	< 5.0 PSID at rated flow
Max. Temp./Pressure (Aluminum Bowl)	175 °F/200 PSIG
Max. Temp./Pressure (Polycarbonate Bowl)	125 °F/150 PSIG
Approx. Weight (lb.)	3.5
ISO Class	2 Particulate

For higher pressure applications, consult factory. Units equipped with differential pressure indicator have max. temperature and pressure of 125 °F and 150 PSIG, regardless of bowl material.



Water
Dirt
Oil
Oil Vapor
Odor

Replacement Parts & Accessories

Description	Part Number
A Replacement Element	3P-035/3P-060
B Differential Pressure Indicator	N32-W1-DPi
B Blanking Cap (Cover for units without indicator)	N32-95-020
C Bowl Assembly: Metal Bowl, Manual Petcock Drain, O-ring	N34-95-205
C Bowl Assembly: Metal Bowl, Automatic Float Drain, O-ring	N34-95-201
D Bowl Assembly: Poly Bowl, Manual Petcock Drain, O-ring*	N32-15-163
D Bowl Assembly: Poly Bowl, Automatic Float Drain, O-ring*	N32-15-165
E Manual Petcock Drain (Metal Bowl)	PC-02
E Manual Petcock Drain (Poly Bowl)	N32-95-182
F Automatic Float Drain (Metal Bowl)	N32-95-979
F Automatic Float Drain (Poly Bowl)	N32-95-973
G Bowl O-ring	N32-95-257
Mounting Bracket (Optional)	BK-1

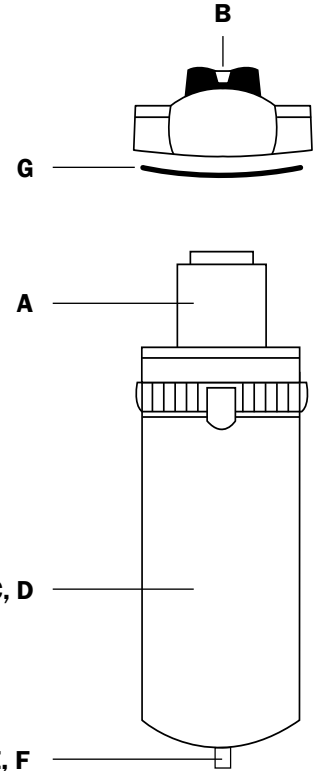

Order Guide

Drain Type	Port Size	Model Number				Dimensions (in.)	
		Metal Bowl		Poly Bowl		Height**	
		Low Flow	Med Flow	Low Flow	Med Flow	Metal	Poly
Manual	1/4"	3P-035-M02-P	3P-060-M02-P	3P-035-P02-P	3P-060-P02-P	10.0	11.0
	3/8"	3P-035-M03-P	3P-060-M03-P	3P-035-P03-P	3P-060-P03-P	Width	Depth
	1/2"	3P-035-M04-P	3P-060-M04-P	3P-035-P04-P	3P-060-P04-P	3.7	3.9
Automatic	1/4"	3P-035-M02-F	3P-060-M02-F	3P-035-P02-F	3P-060-P02-F	Height**	
	3/8"	3P-035-M03-F	3P-060-M03-F	3P-035-P03-F	3P-060-P03-F	Metal	Poly
	1/2"	3P-035-M04-F	3P-060-M04-F	3P-035-P04-F	3P-060-P04-F	10.0	11.0

*Poly bowls come with metal bowl guard

**To add an indicator, add "I" to end of model number (Indicator adds about 1" to height)

Specifications

Port Sizes	½", ¾", 1"
Thread Styles	NPT, BSPT, BSPP
Flow Capacity	90/150 SCFM @ 100 PSI
Filter Capacity	1.0 micron & larger
Differential Pressure	< 5.0 PSID at rated flow
Max. Temp./Pressure (Aluminum Bowl)	175 °F/200 PSIG
Max. Temp./Pressure (Polycarbonate Bowl)	125 °F/150 PSIG
Approx. Weight (lb.)	6.0
ISO Class	2 Particulate

For higher pressure applications, consult factory. Units equipped with differential pressure indicator have max. temperature and pressure of 125 °F and 150 PSIG, regardless of bowl material.



Water
Dirt
Oil
Oil Vapor
Odor

Replacement Parts & Accessories

Description	Part Number
A Replacement Element	3P-090/3P-150
B Differential Pressure Indicator	N32-W1-DPI
B Blanking Cap (Cover for units without indicator)	N32-95-020
C Bowl Assembly: Metal Bowl, Manual Petcock Drain, O-ring	N34-15-180
C Bowl Assembly: Metal Bowl, Automatic Float Drain, O-ring	N34-15-178
D Bowl Assembly: Poly Bowl, Manual Petcock Drain, O-ring*	N32-15-167
D Bowl Assembly: Poly Bowl, Automatic Float Drain, O-ring*	N32-15-035
E Manual Petcock Drain (Metal Bowl)	PC-03
E Manual Petcock Drain (Poly Bowl)	N32-95-182
F Automatic Float Drain (Metal Bowl)	N32-95-979
F Automatic Float Drain (Poly Bowl)	N32-95-973
G Bowl O-ring	N32-95-256
Mounting Bracket (Optional)	N32-95-734

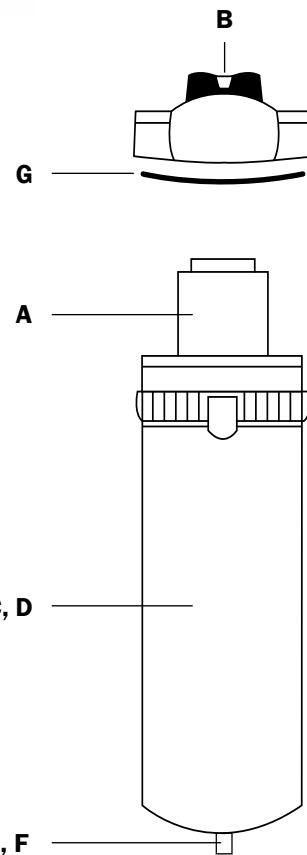

Order Guide

Drain Type	Port Size	Model Number				Dimensions (in.)	
		Metal Bowl		Poly Bowl		Height**	
		Low Flow	Med Flow	Low Flow	Med Flow	Metal	Poly
Manual	½"	3P-090-M04-P	3P-150-M04-P	3P-090-P04-P	3P-150-P04-P	17.0	14.0
	¾"	3P-090-M06-P	3P-150-M06-P	3P-090-P06-P	3P-150-P06-P	Width	Depth
	1"	3P-090-M08-P	3P-150-M08-P	3P-090-P08-P	3P-150-P08-P	4.6	4.8
Automatic	½"	3P-090-M04-F	3P-150-M04-F	3P-090-P04-F	3P-150-P04-F	Height**	
	¾"	3P-090-M06-F	3P-150-M06-F	3P-090-P06-F	3P-150-P06-F	Metal	Poly
	1"	3P-090-M08-F	3P-150-M08-F	3P-090-P08-F	3P-150-P08-F	17.0	15.0

*Poly bowls come with metal bowl guard

**To add an indicator, add "i" to end of model number (Indicator adds about 1" to height)