

8 7 6 5 4 3 2 1

THIS DRAWING & SPECIFICATIONS ARE PROPERTY OF MORGANTON PRESSURE VESSELS AND MAY NOT BE COPIED, REPRODUCED, OR USED IN WHOLE OR PART, AS A BASIS FOR DESIGN MANUFACTURE OR SALE WITHOUT PRIOR PERMISSION FROM MORGANTON PRESSURE VESSELS.

DESIGN INFORMATION	
SPECIFICATION	VALUE
DIAMETER (O.D.)	12.000"
MAWP	200 PSI AT 650°F
MDMT	-20°F AT 200 PSI
CAPACITY	APPROX 15 GALLONS
APPROX. WEIGHT	45 LBS

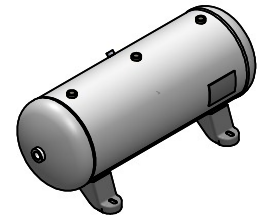
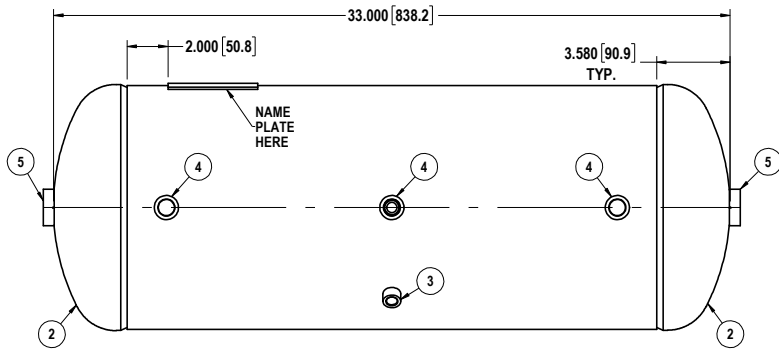
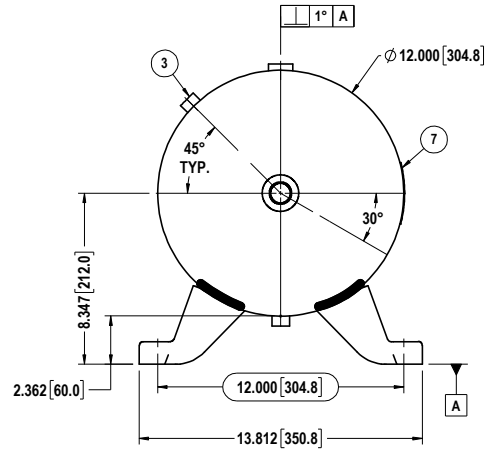
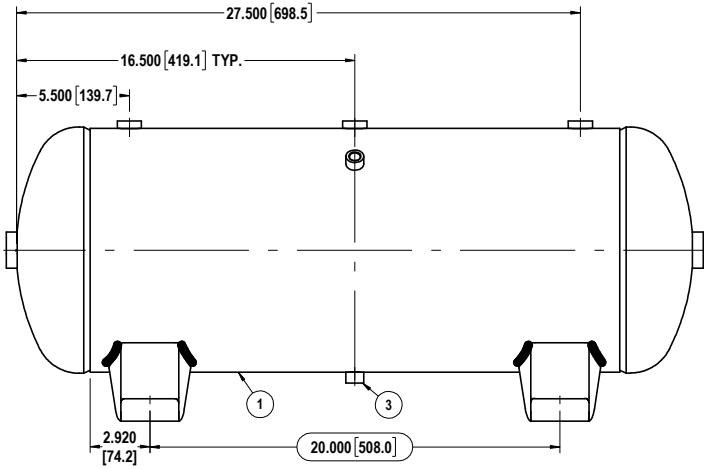

ITEM#	DESCRIPTION	QTY.	PART #
7	NAME PLATE	1	LAB00038
6	LEG	4	LEG00058
5	3/4" NPT COUPLING	2	SOK00289
4	1/2" NPT COUPLING	3	SOK00286
3	1/4" NPT COUPLING	2	SOK00313
2	HEAD	2	HEA00441
1	SHELL	1	PSV03517

	TOLERANCES, IF NOT INDICATED, ACCORDING TO: C-G SE 03.03 / 3
	DWG. NO. <b>VES0010061</b>
	REV. 0

NOT FOR PRODUCTION USE

8 7 6 5 4 3 2 1