

REV	DESCRIPTION	ECN #	CHG BY	DATE	APP'D
A	ADDED ITEM 23, 2" BIOHAZARD LABEL	PJCT288	JR	07/29/15	CRW
B	DRAIN WAS 1/4" NPT BRASS; UPDATED CASTING DESIGN	16367	NAS	06/03/19	EZR
C	NOTE WAS NPSC, CASTING IS NPT	-	NAD	06/18/19	TAS
D	UPDATED DRAIN, WAS SS, ADDED LABEL/NOTES	21416	EZR	03/08/21	TAS

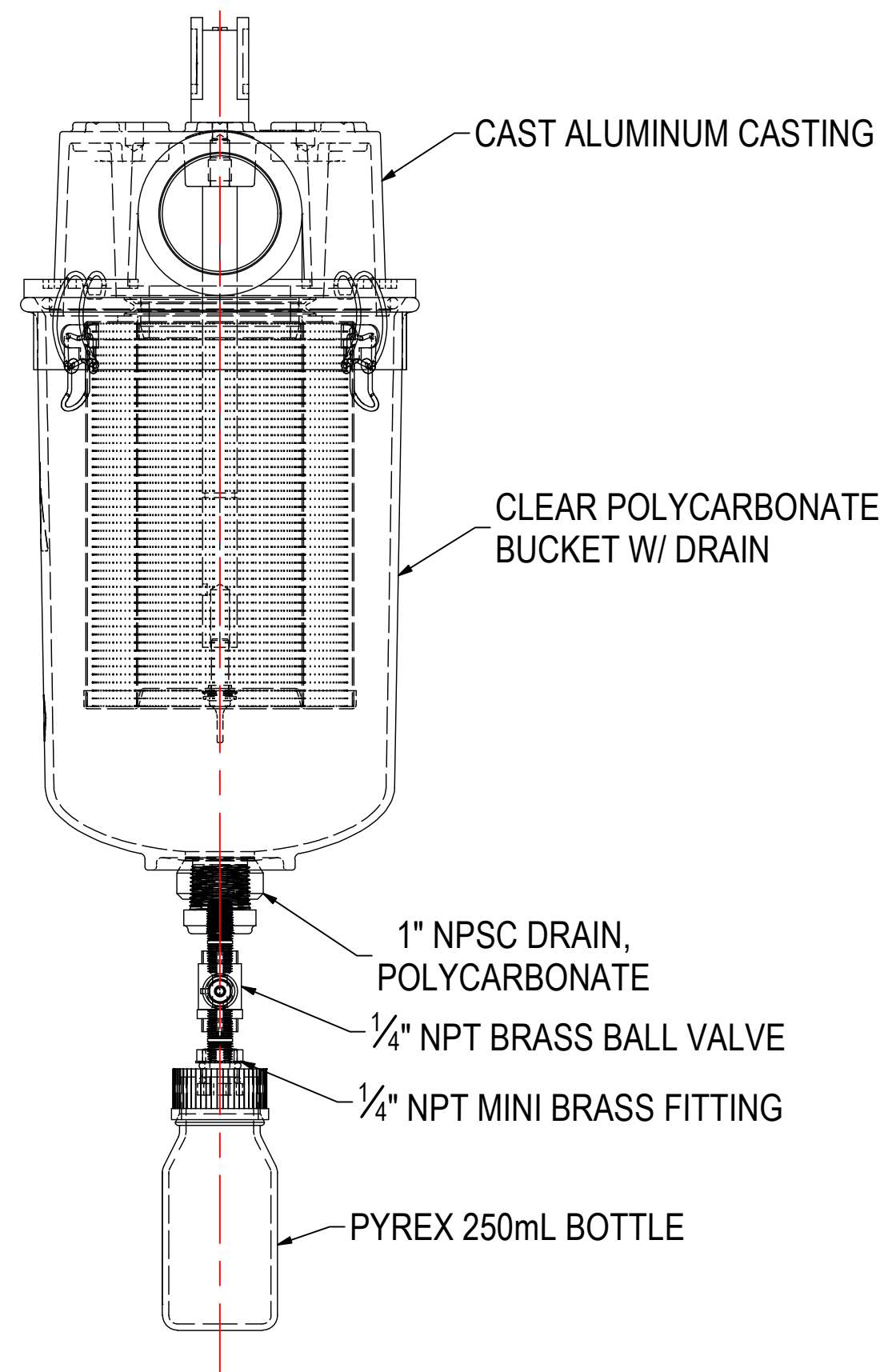

ELEMENT SPECS		
PART NUMBER	UL850/1	
MATERIAL	ULPA	
FLOW RATE	129 CFM	219 m ³ /hr
SURFACE AREA	13.1 ft ²	1.2 m ²
I.D.	3.50"	89mm
O.D.	5.88"	149mm
HEIGHT	8.58"	218mm

MODEL #: HV-UL850/1-250C	MATERIAL: VARIOUS	FINISH: VARIOUS
MODEL NUMBER: HV-UL850/1-250C		SHEET: 1 OF 2
DESCRIPTION: HV-UL850/1-250C, BOTTLE, BALL VALVE, PD GAUGE		
PROJECT:	DRAWN BY: CRW	APPROVED BY:
	DATE: 4/6/2015	DATE:
		REV: D

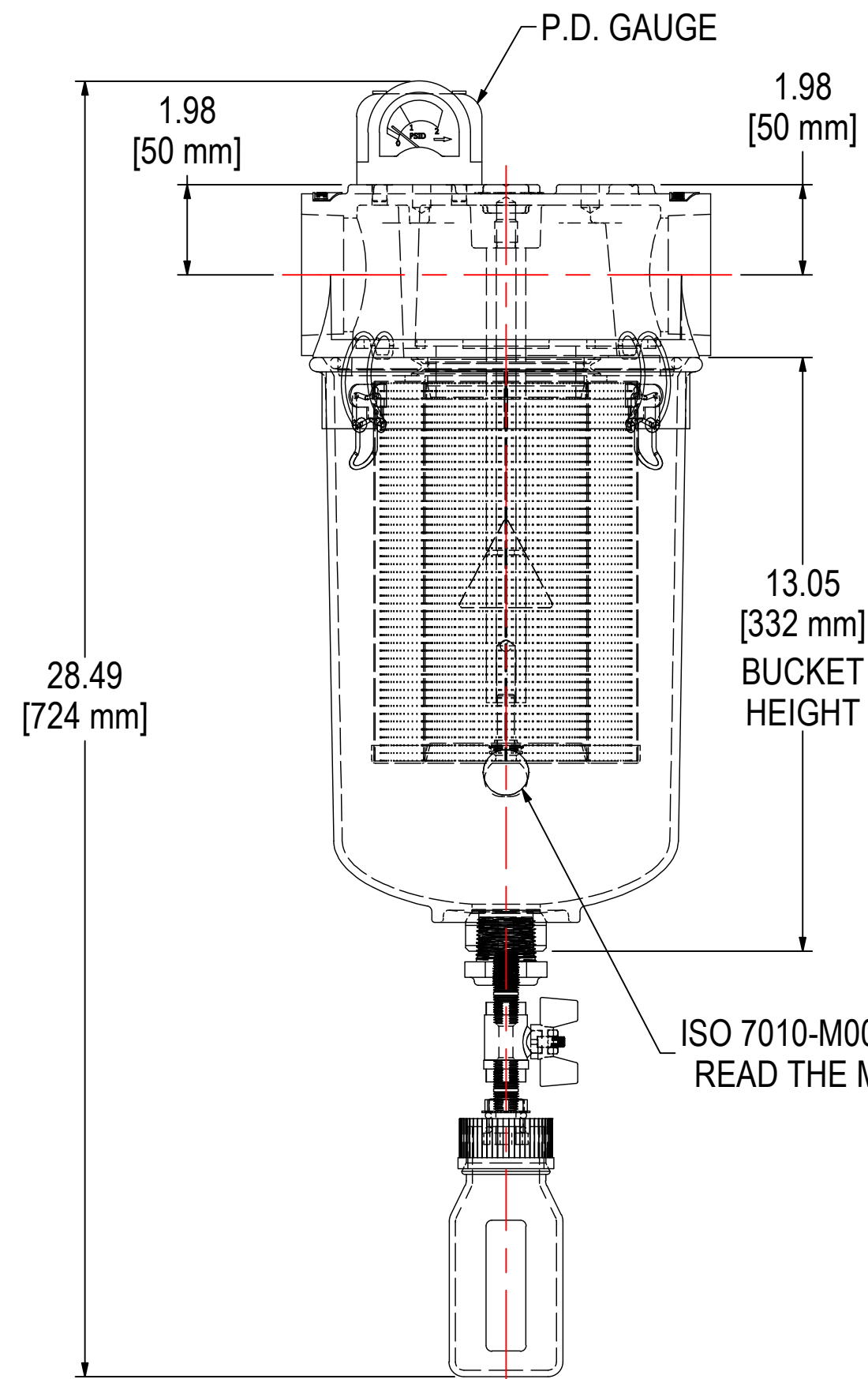
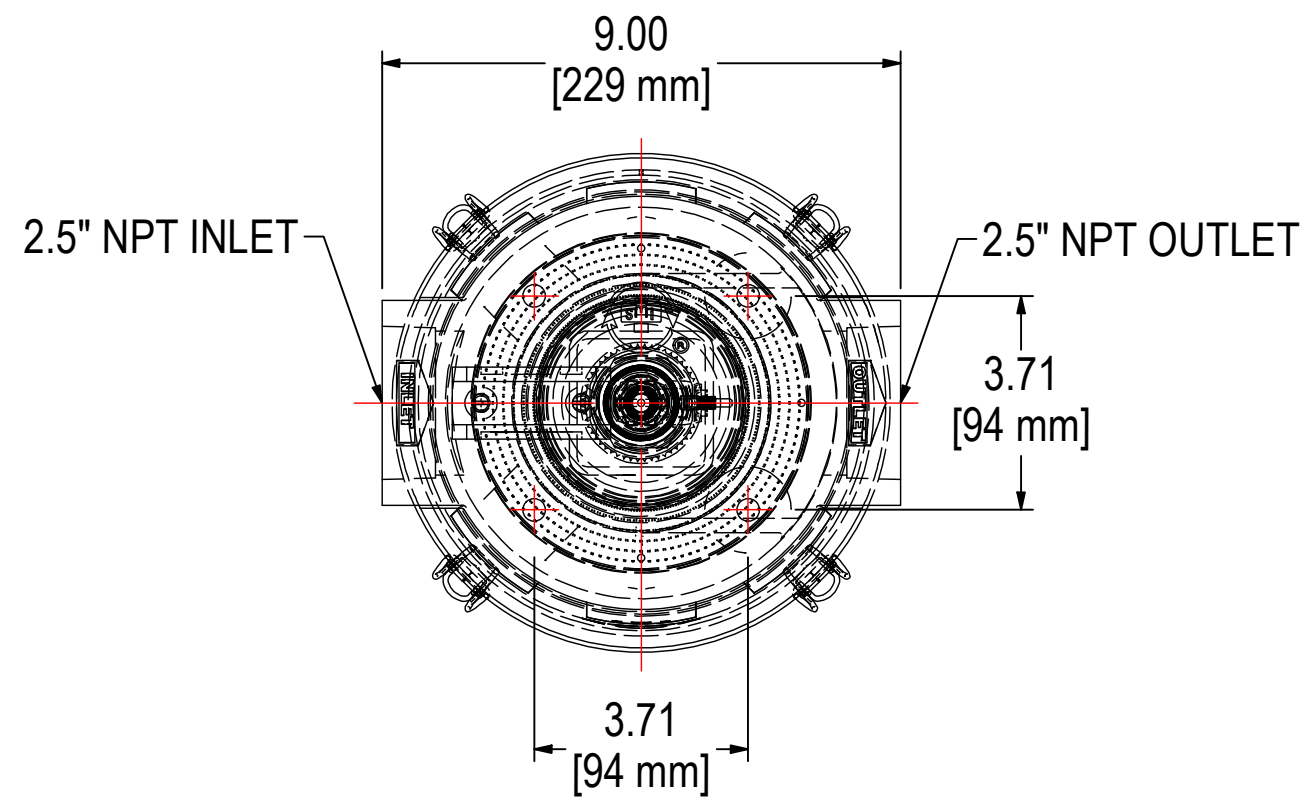

THE INFORMATION CONTAINED HEREIN IS CONFIDENTIAL AND THE PROPERTY OF SOLBERG MANUFACTURING INC. AND IT IS FURNISHED TO YOU WITH THE EXPRESS UNDERSTANDING THAT IT WILL NOT BE REPRODUCED, COPIED IN ANY MANNER, LOANED OR OTHERWISE TRANSFERRED TO OTHERS ENTIRELY OR IN PART, NOR USED FOR ANY PURPOSE OTHER THAN FOR WHICH IT WAS FURNISHED. IT WILL BE RETURNED UPON REQUEST TO SOLBERG MANUFACTURING INC. THE ABOVE RESTRICTION IS IN ADDITION TO, AND DOES NOT IN ANY WAY ALTER, ANY OTHER RESTRICTIONS WHICH MAY APPLY TO THE INFORMATION CONTAINED HEREIN.

TOLERANCES
 DIMENSIONS ARE FOR REFERENCE ONLY. ALL DIMENSIONS ARE SUBJECT TO CHANGE UPON PRODUCTION.
 UNLESS OTHERWISE SPECIFIED:
 -DIMENSIONS ARE IN INCHES
 -REF: APPROXIMATE DIMENSIONS, NO TOLERANCES APPLY
 -FINISH: BREAK EDGES TO .005-.020 RADIUS/CHAMFER