

4

3

2

1

MODEL	DIMENSIONS													CONNECTIONS <ANSI FLANGE>	INLET AIR FLOW <scfm>	NET WEIGHT <lbs>	POWER SUPPLY	REFRIGERANT
	A	B	C	D	E	F	G	H	I	J	K	L	M					
HGEN800	31.10 {790}	21.10 {536}	10.00 {254}	26.77 {680}	28.35 {720}	37.40 {950}	41.34 {1050}	59.83 {1519.6}	22.11 {561.6}	28.35 {720}	3.35 {85}	6.12 {155.5}	35.22 {894.5}	3"	800	695	460V/3PH/60Hz	R407c

NOTE: PRIMARY DIMENSIONS ARE INCHES
& DIMENSIONS IN BRACES ARE METRIC

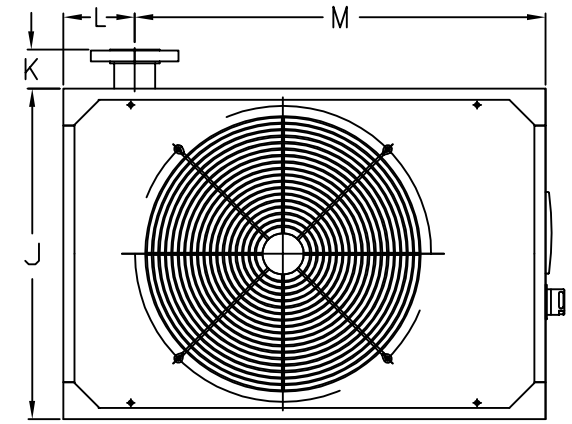

SERVICE :
COMPRESSED AIR

OPERATING CONDITIONS :
 RATED INLET AIR PRESSURE- 100 PSIG
 MAXIMUM INLET AIR PRESSURE- 232 PSIG
 MINIMUM INLET AIR PRESSURE- 43.5 PSIG
 RATED INLET AIR TEMPERATURE- 100°F
 MAXIMUM INLET AIR TEMPERATURE- 120°F
 MINIMUM INLET AIR TEMPERATURE- 45°F
 RATED AMBIENT AIR TEMPERATURE- 86°F
 MAXIMUM AMBIENT AIR TEMPERATURE- 109°F
 MINIMUM AMBIENT AIR TEMPERATURE- 37°F

SPECIFICATIONS:
 CONDENSER TYPE- AIR COOLED
 DRAIN TYPE -ELECTRONIC AUTO DRAIN VALVE
 EXPANSION DEVICE- CONSTANT PRESSURE EXPANSION VALVE

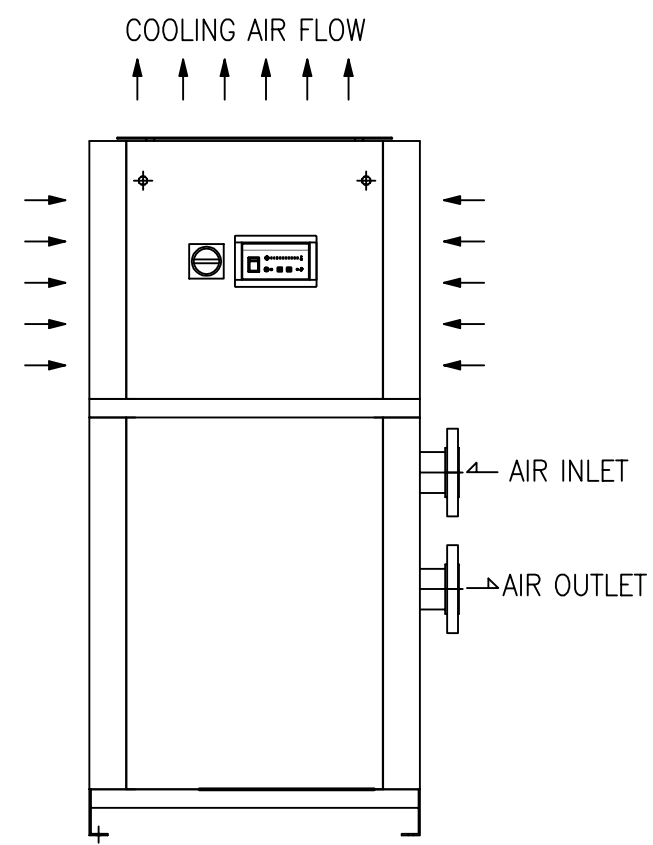
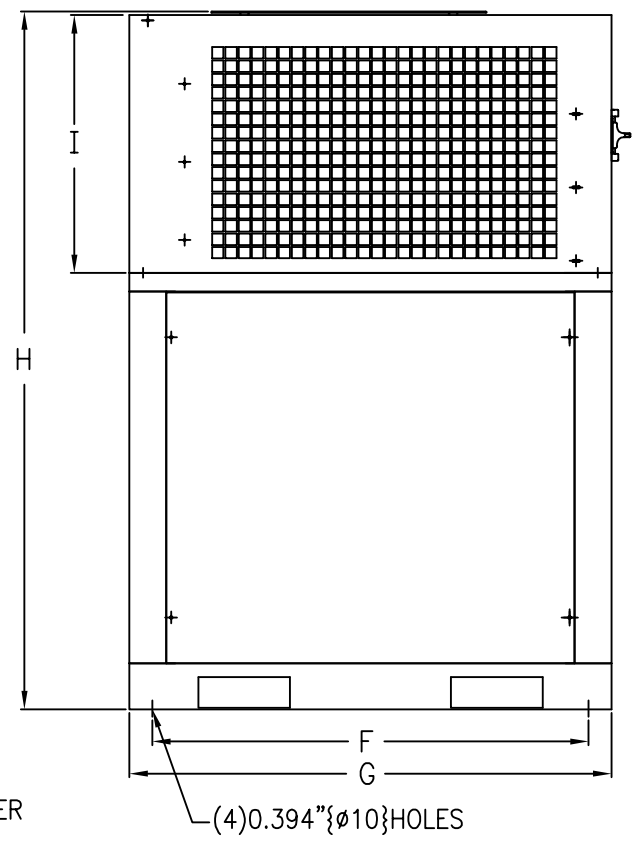
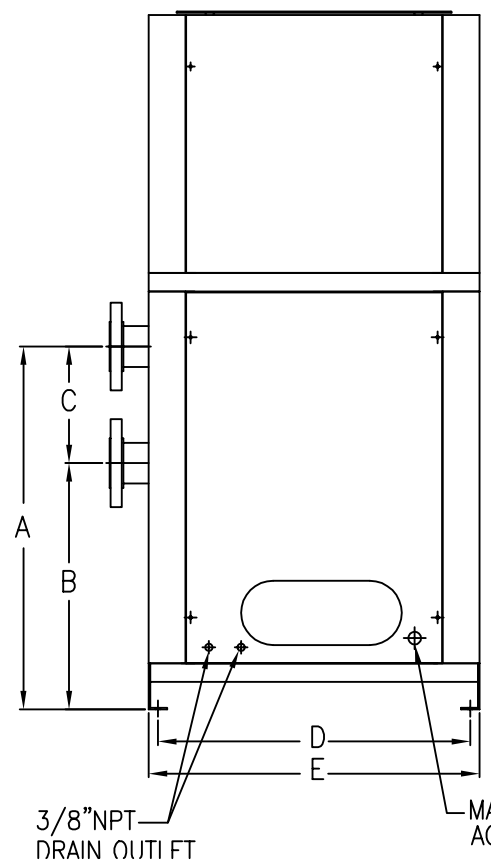

REV.	DESCRIPTION	BY	DATE	APPROVED
REVISION HISTORY (Δ INDICATES LATEST REVISION)				

UNLESS OTHERWISE SPECIFIED
 DIMENSIONS ARE IN INCHES
 TOL. ON FRACTIONS: $\pm 1/16$
 TOL. ON DECIMALS: $\pm .03$ (2 PLACE)
 TOL. ON DECIMALS: $\pm .015$ (3 PLACE)
 TOL. ON ANGLES: ± 1.5

THIRD ANGLE PROJECTION

DRAWN BY: NLC
 DATE: 1/26/17

CHECKED BY: NLC
 DATE: 1/26/17

APPROVED BY: NLC
 DATE: 1/26/17

GENERAL ASSEMBLY
 HGEN 800- AIR COOLED

SIZE B

DWG. NO. GA03DEL-0057

SCALE: NONE EST. WT. SHEET 1 OF 1

4

3

2

1