

ZONE		REV	DESCRIPTION	CHG BY	CHK BY	APP BY	REL BY	DATE
-	A		REVISED DETAIL "A".	SDM	DEH	DEH	SDM	11/24/04
-	B		CHANGED FILTER PACKAGES.	SDM	DEH	DEH	SDM	10/16/06
-	C		REMOVED UNNEEDED DETAIL A	DL	DEH	DEH	SDM	02/16/07
-	D		CHANGED ASME RELIEF VALVE	LLS	SDM	SDM	SDM	02/19/08
-	E		CHANGE ELECTRICAL PANEL & VALVE	CPG	SDM	SDM	SDM	03/22/10
-	F		REMOVED FRONT, BACK & INNER ANGLES OF DRYER RELOCATED HEATER MTG BRKT & INSTRUMENTS	NSD/BEC	DEH	DEH	NSD/BEC	04/10/18
B-4	G		ADDED SINGLE PROBE DUAL RTD/THERMOCOUPLE	SOM/BEC	KL	DEH	SOM/BEC	05/31/19

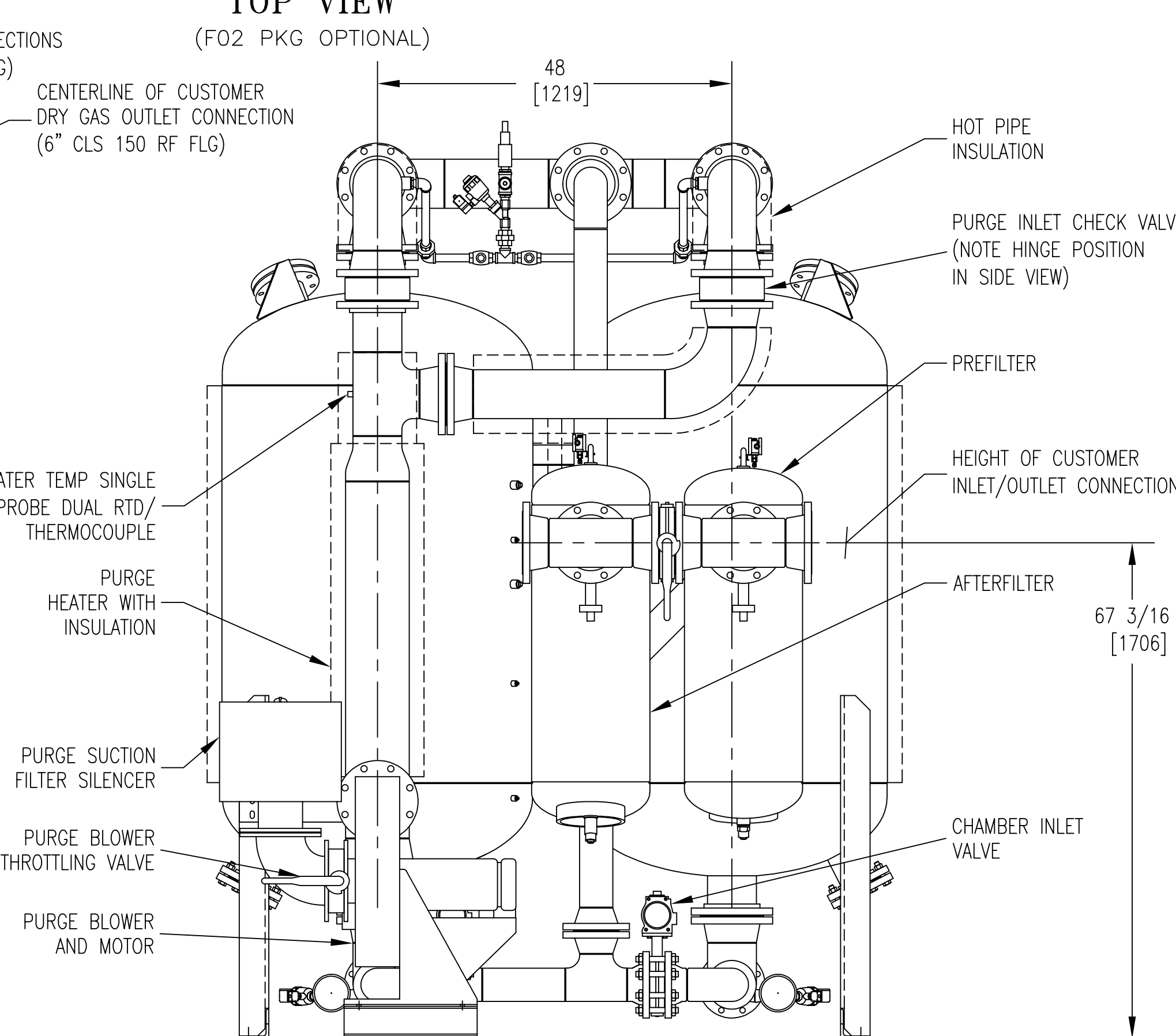
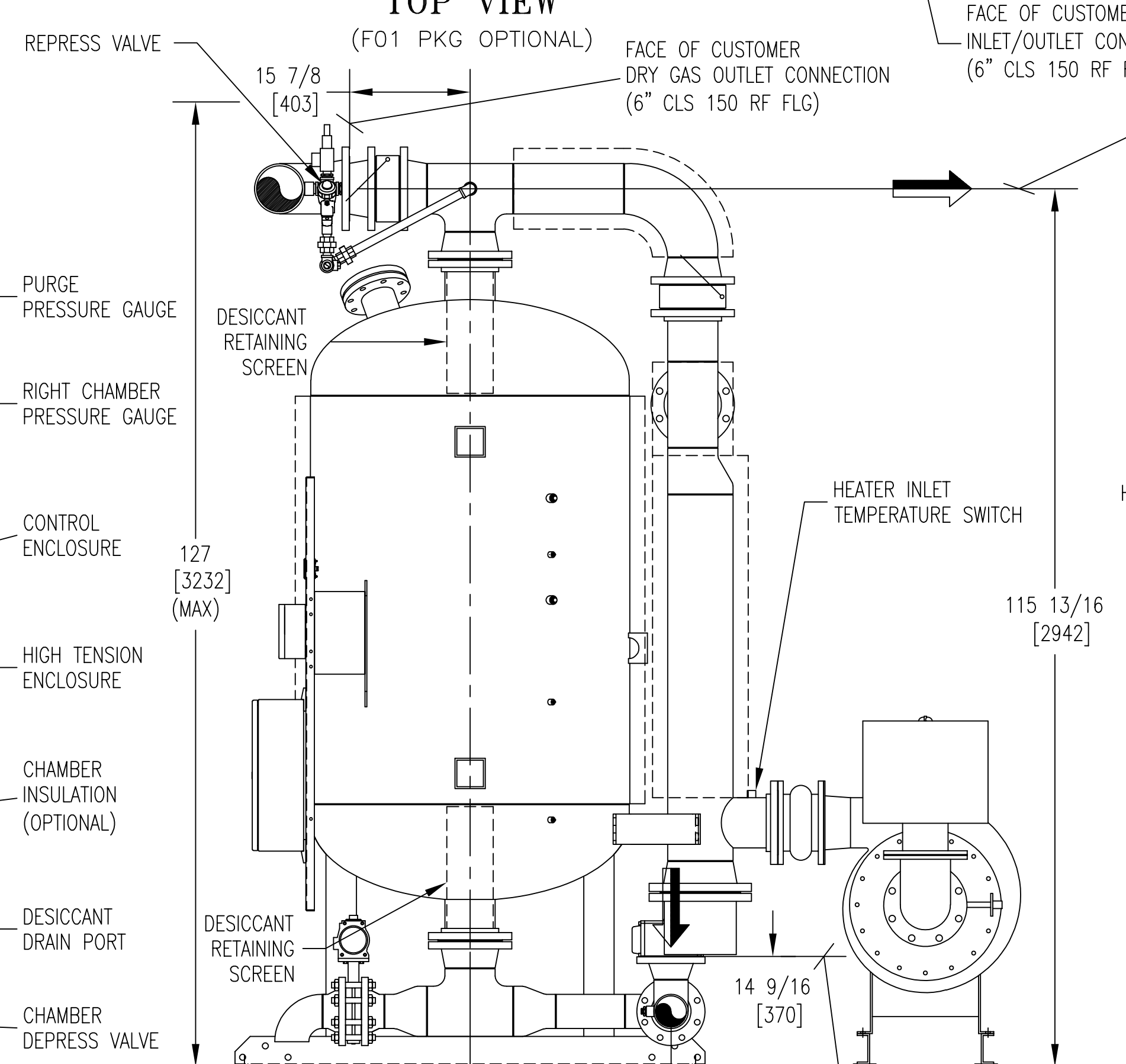
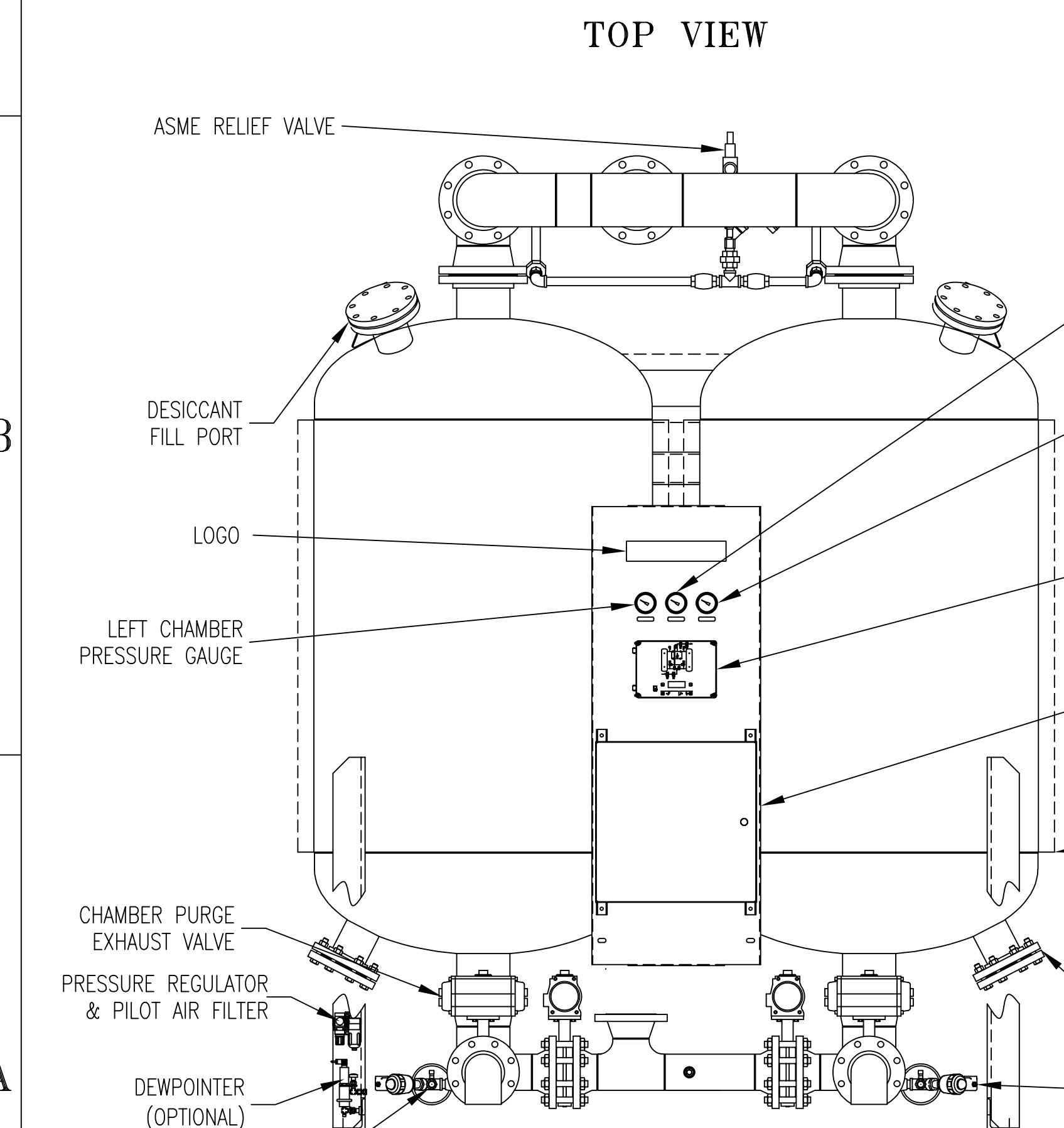
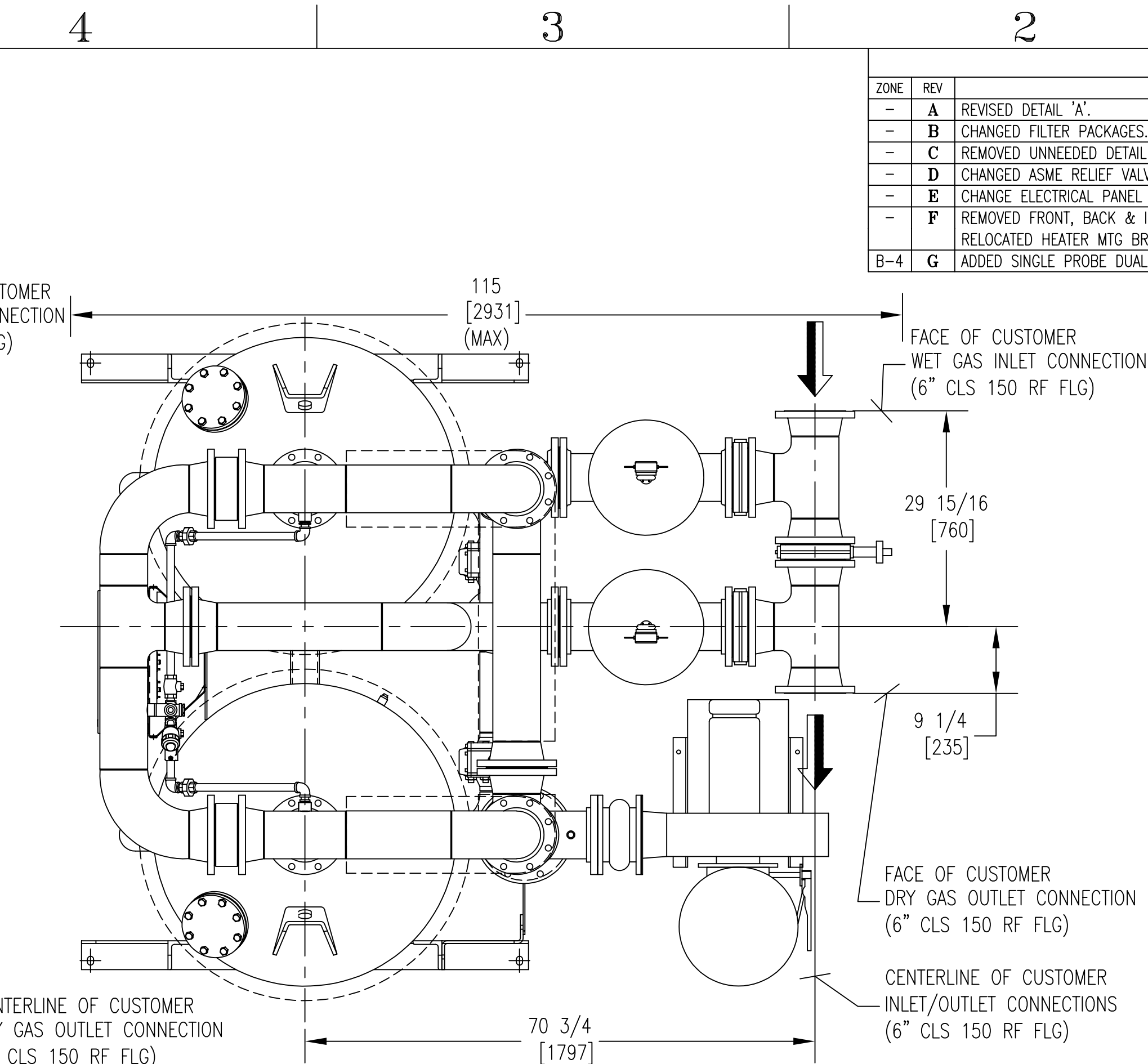
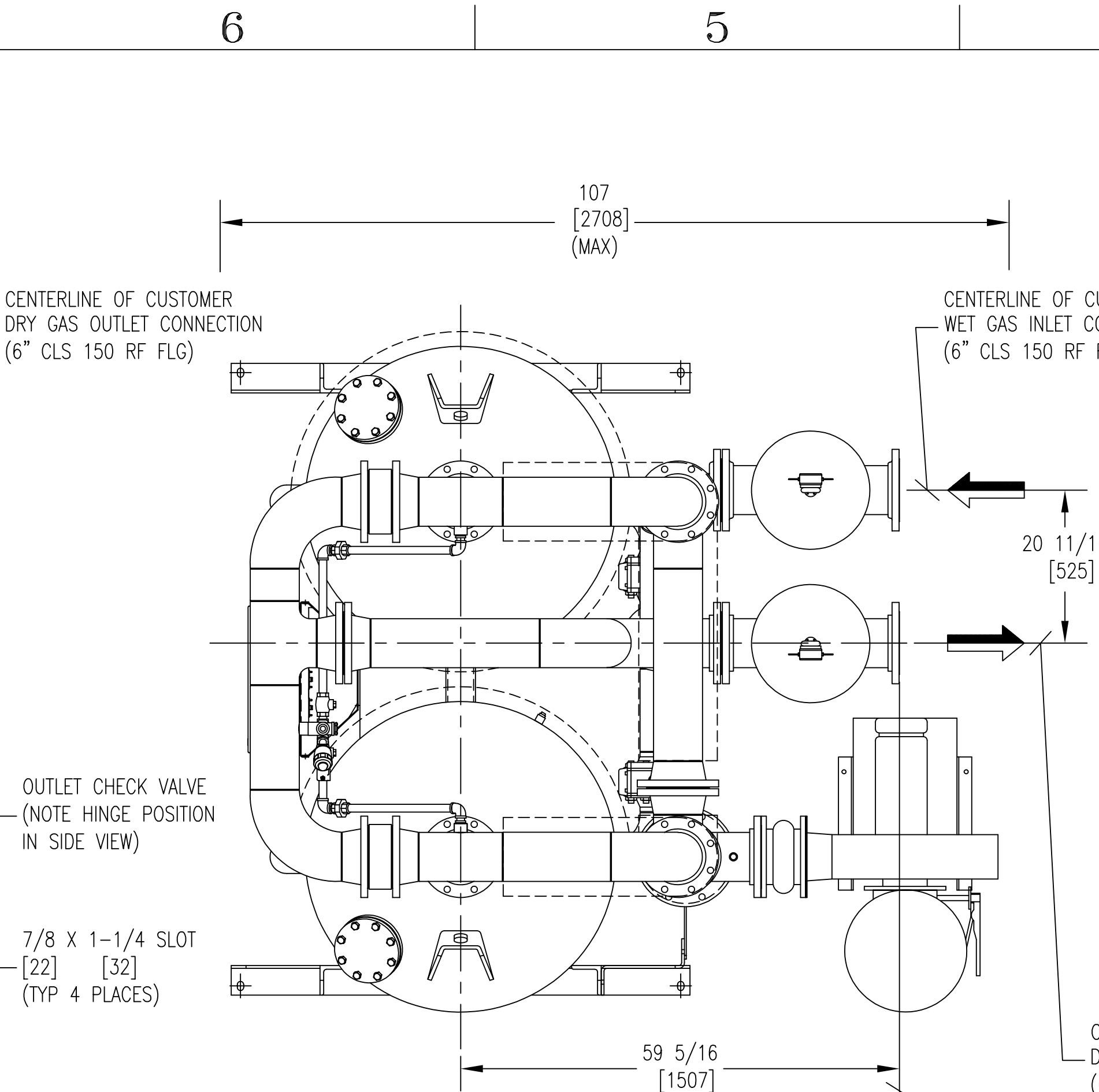
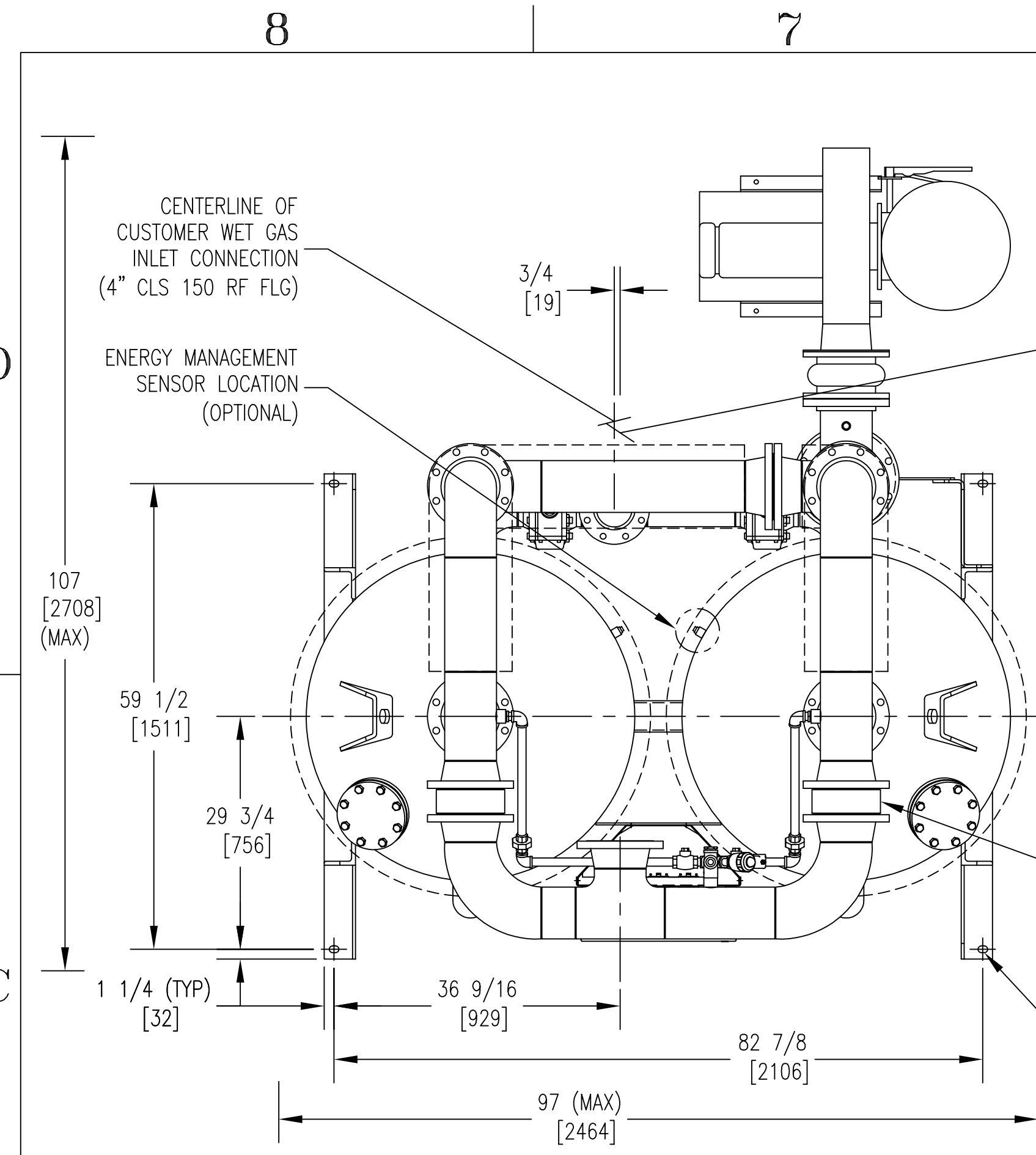

- NOTES:**
- THIS DRAWING, TOGETHER WITH THE P&ID AND SPECIFICATION SHEET, PROVIDES OPERATING CONDITIONS, SPECIFICATIONS, INSTALLATION, MOUNTING AND CONNECTION REQUIREMENTS.
 - PRESSURE VESSELS ARE DESIGNED AND BUILT IN ACCORDANCE WITH THE CURRENT EDITION AND ADDENDA OF SECTION VIII, DIV. I, OF THE A.S.M.E. CODE FOR UNFIRED PRESSURE VESSELS.
 - ELECTRICAL CONSTRUCTION IS IN ACCORDANCE WITH THE NATIONAL ELECTRICAL CODE.
 - ANCHOR BOLTS ARE TO PROJECT A MINIMUM OF 2" ABOVE THE FOUNDATION. ANCHOR BOLTS SHOULD BE INSTALLED IN SLEEVES TO ALLOW SOME ADJUSTMENT AT TIME OF INSTALLATION.
 - FOR MAINTENANCE PURPOSES, RECOMMENDED CLEARANCE AROUND DRYER IS 4 FT [1220 MM].
 - IF THE EQUIPMENT IS TO DRY (OR REACTIVATE) WITH A GAS OTHER THAN AIR, THE OUTLETS OF THE SAFETY VALVE, REACTIVATION GAS OUTLET LINE, BLOWDOWN VALVES, ETC. SHALL BE PIPED AWAY TO A SAFE LOCATION (BY PURCHASER). IN PIPING AWAY GAS, DO NOT PIPE UPWARD WITHOUT ADEQUATE ARRANGEMENTS TO PREVENT TRAPPING CONDENSATION.
 - WEIGHTS: SHIPPING WEIGHT 8,963 LBS. (APPROX.)
OPERATING WEIGHT 8,963 LBS. (APPROX.)
4,066 KGS
4,066 KGS
 - WHEN FILTER OPTION IS SUPPLIED, REMOVE FILTER AND FILTER PIPING FOR SHIPPING.

UNLESS OTHERWISE SPECIFIED:		NAME	DATE	UNAUTHORIZED USE, MANUFACTURE, OR REPRODUCTION IN WHOLE OR IN PART IS PROHIBITED. DRAWING DESIGN AND OTHER DISCLOSURES ARE PROPERTY OF:
DIMENSIONS ARE IN: INCHES/MM		DWN BY	SDM	11/08/04
SURFACE FINISH: N/A ✓		ENG BY	DEH	11/08/04
TOL.		CHK BY	SDM	11/08/04
X.		APP BY	DEH	11/08/04
.XX		REL BY	SDM	11/08/04
.XXX				
FRACT: ±1/2	ANG: ±2°	MAT NO.	----	SIZE DWG. NO.
SCALE: 1/16	WT: N/A			D 0017108-3200
				REV. SHEET
				G 1/1

Deltech
* DO NOT SCALE. DIMENSIONS ONLY *

GENERAL ARRANGEMENT
ZP 3200