



nano



membrane compressed air dryers

flow capacity: 3.2 to 74.2 scfm (5.5 to 126 Nm³/hr)

“Class 4 air is acceptable for 95% of our plant, but a few processes needed drier air. The M¹ is the perfect solution.”

a research laboratory - southwestern US

Clean, dry compressed air is essential in every efficient and profitable manufacturing operation worldwide.

Ambient air contains high levels of moisture, dust, hydrocarbons and other contaminants and, when left untreated, the results can be corrosion, bacteria, mold growth and freezing water within your compressed air lines. This contamination can cause damage to downstream equipment and lead to increased maintenance, downtime and product spoilage.

While compressed air filters will remove solid particulate, liquids and aerosols, they cannot remove the moisture that remains in the form of vapor. This vapor condenses into liquid water throughout your compressed air system as the pressure and temperature of the compressed air changes.

nano M¹ membrane compressed air dryers

- removal of water vapor by lowering the pressure dew point of your compressed air stream from 100°F to 55°F to ensure a continuous supply of dry air
- low pressure drop and reduced purge air use lower the costs of producing dry air
- designed for the most demanding applications the M¹ membrane dryer is suitable for a broad range of installations and operating conditions

technologically
advanced



BENEFITS

energy efficient

- designed for minimal pressure drop and optimized for the highest drying efficiency

choice of performance

- with seven model sizes and two grades of membrane available, the M¹ membrane dryer has a wide performance range to offer you the exact level of dry air required to meet your needs



designed for demanding applications

- provides clean, dry compressed air in environments with strict safety or environmental requirements such as low flow environments, noise and corrosion sensitive areas, areas without electrical supply and locations with explosion proof requirements.
- the perfect design for environments with space restrictions, widely fluctuating temperatures or high vibration areas

easy to install

- with 2 grades of inlet filtrations included and multiple installation orientation possibilities the M¹ is ready for your installation

safe & reliable

- requiring no electrical power for operation, the M¹ membrane dryer is suitable for installation in hazardous areas

easy to maintain

- with no moving or wearing parts the M¹ membrane dryer only requires that the inlet filters be serviced over its life



HOW IT WORKS

A membrane compressed air dryer consists of thousands of hollow fibers sealed inside a hollow tube. The membranes have an innovative surface coating that allows for water to permeate through the fibers while the compressed air remains. The air stream is consequently dried because the water escapes. This dry air will have a dew point that is lowered up to 100°F compared to the original membrane dryer inlet dew point conditions. The membrane is able to work continuously by using a portion of the dried air to purge the moisture removed out of the system through the exhaust vents.

A after being purified by the included inlet filters the wet air enters the bottom endcap through one of the (2) available inlet connections

B air then travels through the membrane bundle

C as wet compressed air passes through the membrane bundle water vapor permeates through the membrane wall while the air remains inside the membrane tubes

D the straight path through the tubes ensures a minimal pressure drop and proprietary membrane coating minimizes air leakages

E as the dry air exits the membrane tube bundle a small portion of the air is used to purge the water from the membrane

F the purge air passes by the outside of the membrane tubes removing the moisture

G the wet purge air then exits the dryer through the 2 exhaust vents

H dry air ready for use

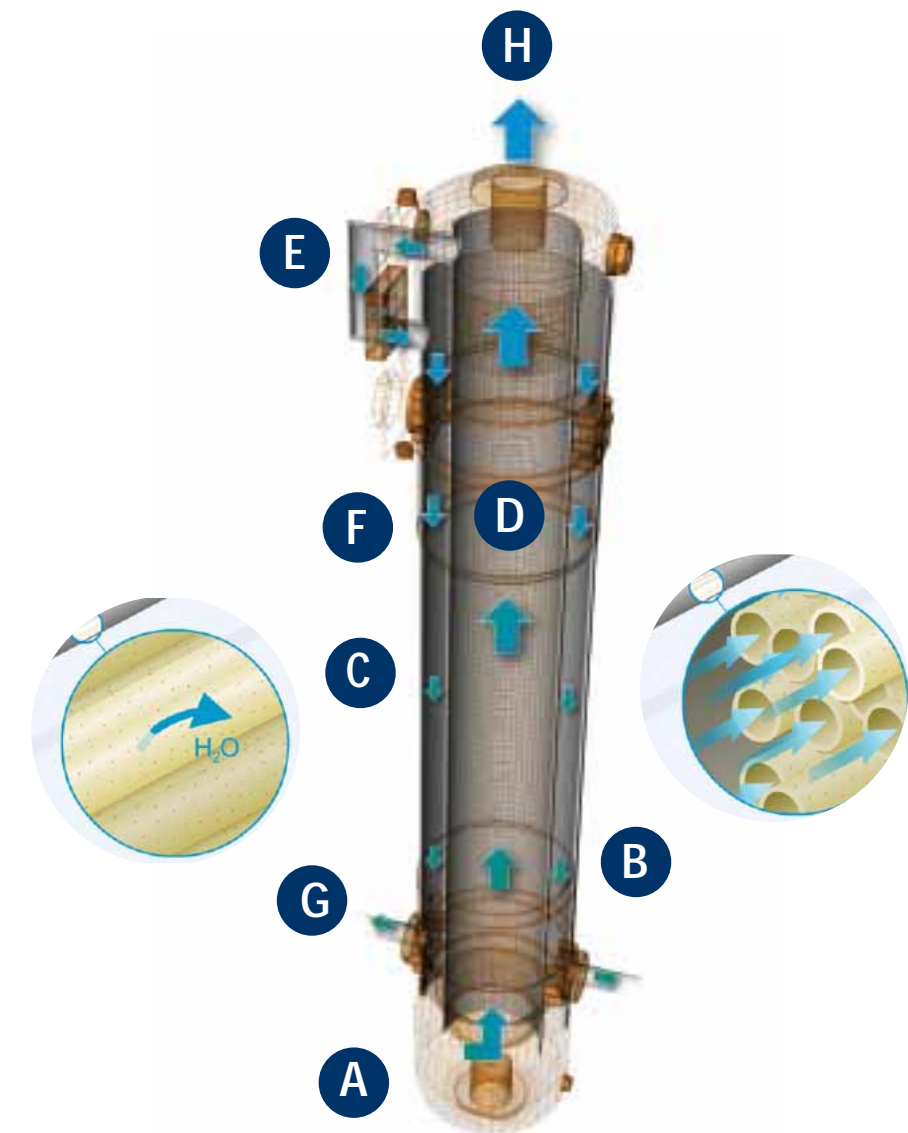

FEATURES

full range gives you exact air type required

- the 55F range ensures suppression of 55°F, producing an outlet air dew point of 40°F which is similar to refrigerated air dryers at reference conditions
- for even dryer air the 100F range lowers the inlet dew point by 100°F, producing sub freezing pressure dew points at the reference conditions

advanced fiber technology

- thousands of hollow fibers with a unique inner coating increases separation efficiency between the water vapor and air, giving unprecedented low air leakage and lowest purge air loss

optimal inlet air quality

- two pre-filters with all interconnection components included as standard

versatile for maximum flexibility

- inlet and outlet caps allow filters and dryer to be mounted horizontally or vertically

requires no electrical power

- can be easily installed in remote or mobile applications
- the product can be installed in areas with hazardous classifications

options

- purge air stop saves purge when no air consumption is present
- wall mounting kits for ease of installation



SPECIFICATIONS

dryer model	pressure dew point suppression	inlet & outlet NPT (F)	rated flow ⁽¹⁾		dimensions (inches)			approx. weight lbs	filtration ⁽²⁾ pre filters
	°F		scfm	Nm ³ /h	A	B	C		
DHM 0005 55F	57.6	½"	6.4	10.8	5.8	2.2	20.9	6.6	NF 0050 M1/M01
DHM 0010 55F	57.6	½"	10.6	18	5.8	2.2	20.9	6.6	NF 0050 M1/M01
DHM 0020 55F	57.6	½"	19.1	32.4	6.8	3.1	28.9	8.8	NF 0050 M1/M01
DHM 0030 55F	57.6	½"	29.7	50.4	6.8	3.1	28.9	9.3	NF 0050 M1/M01
DHM 0040 55F	57.6	½"	40.3	68.4	7.6	3.9	27.9	11.7	NF 0050 M1/M01
DHM 0050 55F	57.6	½"	53	90	7.6	3.9	27.9	12.6	NF 0050 M1/M01
DHM 0075 55F	57.6	½"	74.2	126	8.6	4.9	28.8	17.4	NF 0070 M1/M01
DHM 0003 100F	99	½"	3.2	5.4	5.8	2.2	28.1	6.6	NF 0050 M1/M01
DHM 0007 100F	99	½"	7.4	12.6	5.8	2.2	40.2	7.1	NF 0050 M1/M01
DHM 0013 100F	99	½"	12.7	21.6	6.8	3.1	42.4	10.4	NF 0050 M1/M01
DHM 0019 100F	99	½"	19.1	32.4	6.8	3.1	42.4	10.4	NF 0050 M1/M01
DHM 0028 100F	99	½"	27.5	46.8	7.6	3.9	42.4	13.4	NF 0050 M1/M01
DHM 0036 100F	99	½"	36	61.2	7.6	3.9	42.4	13.4	NF 0050 M1/M01
DHM 0055 100F	99	½"	55.1	93.6	8.6	4.9	43.8	21.4	NF 0070 M1/M01

specifications	standard
minimum / maximum operating pressure range	53 to 203 psig
minimum / maximum ambient temperature	33.8 to 150.8°F
minimum / maximum inlet temperature	33.8 to 150.8°F

- rated flow capacity: compressed air dryer inlet: 101.5 psig and 95°F; ambient air temperature: 77°F; 100% RH. For all other conditions consult sizing program or contact support@n-psi.com
- dryer includes M1 and M01 pre filters as standard (shipped loose with mounting fittings)
- technical specifications subject to change without notice. Direct inquiries to support@n-psi.com or contact 704.897.2182

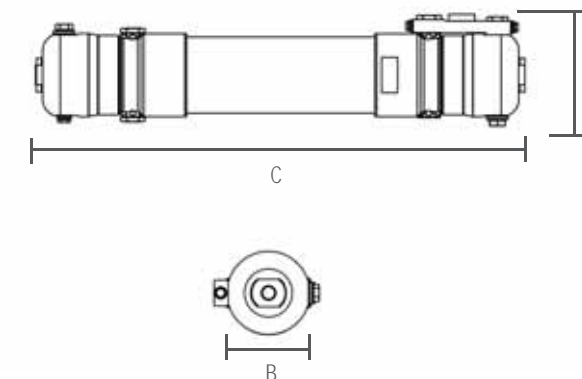

EXPERIENCE. CUSTOMER. SERVICE.

Leading edge technology and hundreds of years of *experience*...nano-purification solutions, your world-class manufacturer of state-of-the-art compressed air and gas solutions to industry.

Our commitment at nano is to work alongside our *customers* and provide unique solutions with the highest quality products to solve your specific challenges.

A wealth of experience and leading edge products are only part of the equation. nano recognize that world-class customer *service* is the most important component to any successful business.



DESIGN

Our experienced team of design engineers are always looking for new and unique technologies and products to bring you the highest level of performance and lowest overall operating cost.

RESEARCH & DEVELOPMENT

Our R&D team endeavor to provide solutions that go beyond developing an existing product. They are continually researching new technologies which can provide unique advantages over competitive offerings.



MANUFACTURE

The reliable and energy saving nano M¹ range of membrane air dryers are manufactured to the highest standards of build quality to ensure equipment reliability and high levels of performance.

ENVIRONMENTALLY FRIENDLY

Through both product development and manufacturing, we strive to produce high quality products compliant to both local and global environmental legislation. Reduction of carbon footprint through energy saving products and use of environmentally friendly components are our commitment to you.



nano-purification solutions
charlotte, north carolina
united states

nano-purification solutions
new bethlehem, pennsylvania
united states

nano-purification solutions
st. catharines, ontario
canada

nano-purification solutions
gateshead, tyne and wear
united kingdom

nano-purification solutions
erkelenz, germany

tel: 704.897.2182
fax: 704.897.2183
email: support@n-psi.com
web: www.n-psi.com

