

REVISIONS					
ZONE	REV	ECN	DESCRIPTION	DATE	APPROVED
	A	2564896	ORIGINAL RELEASE	2025JAN30	C.JEFF B.CHARLES
	B	2564896	WINDCHILL REVISION, UPDATED DIGITAL DISPLAY	2025JUN03	C.JEFF B.CHARLES

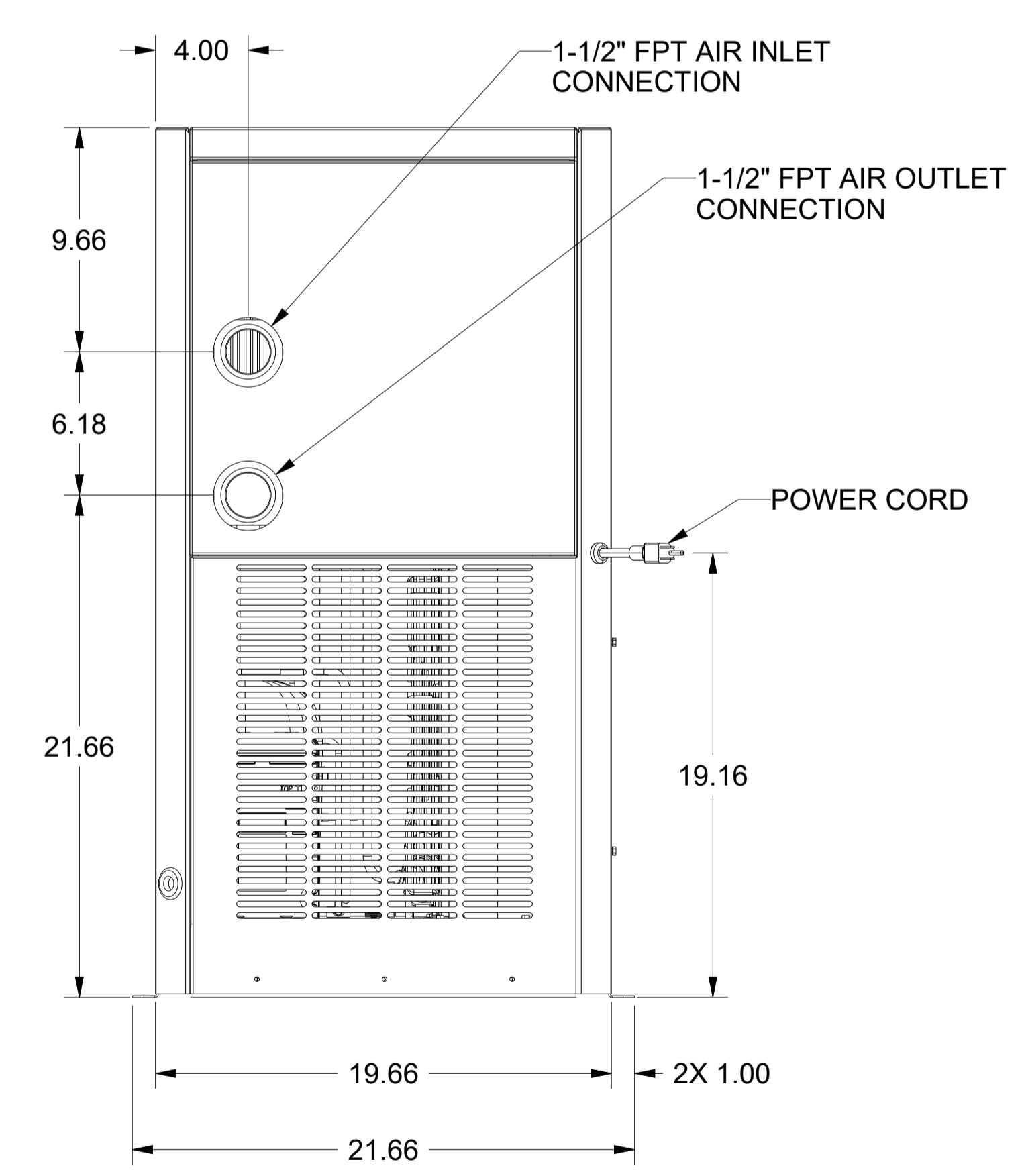
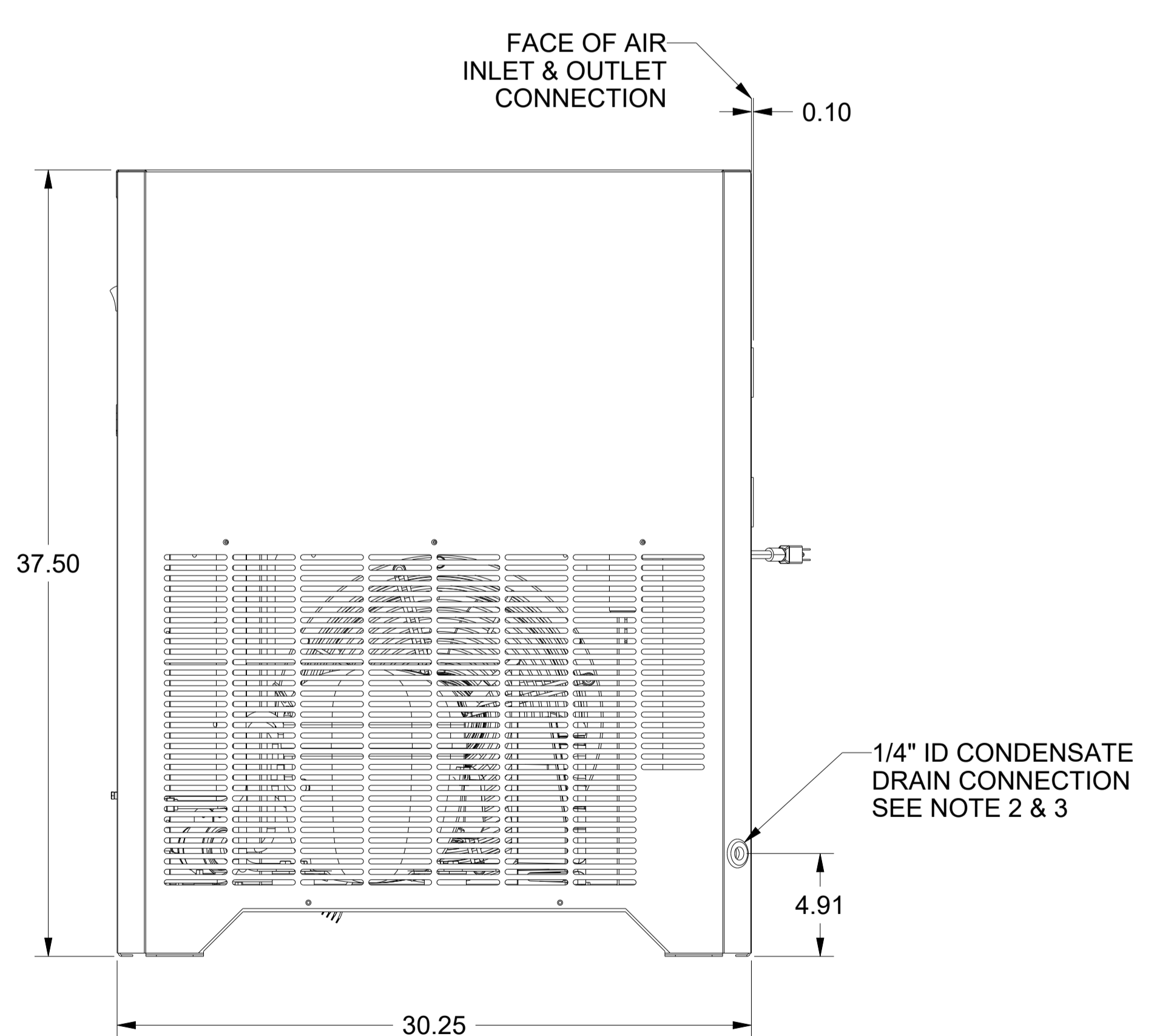
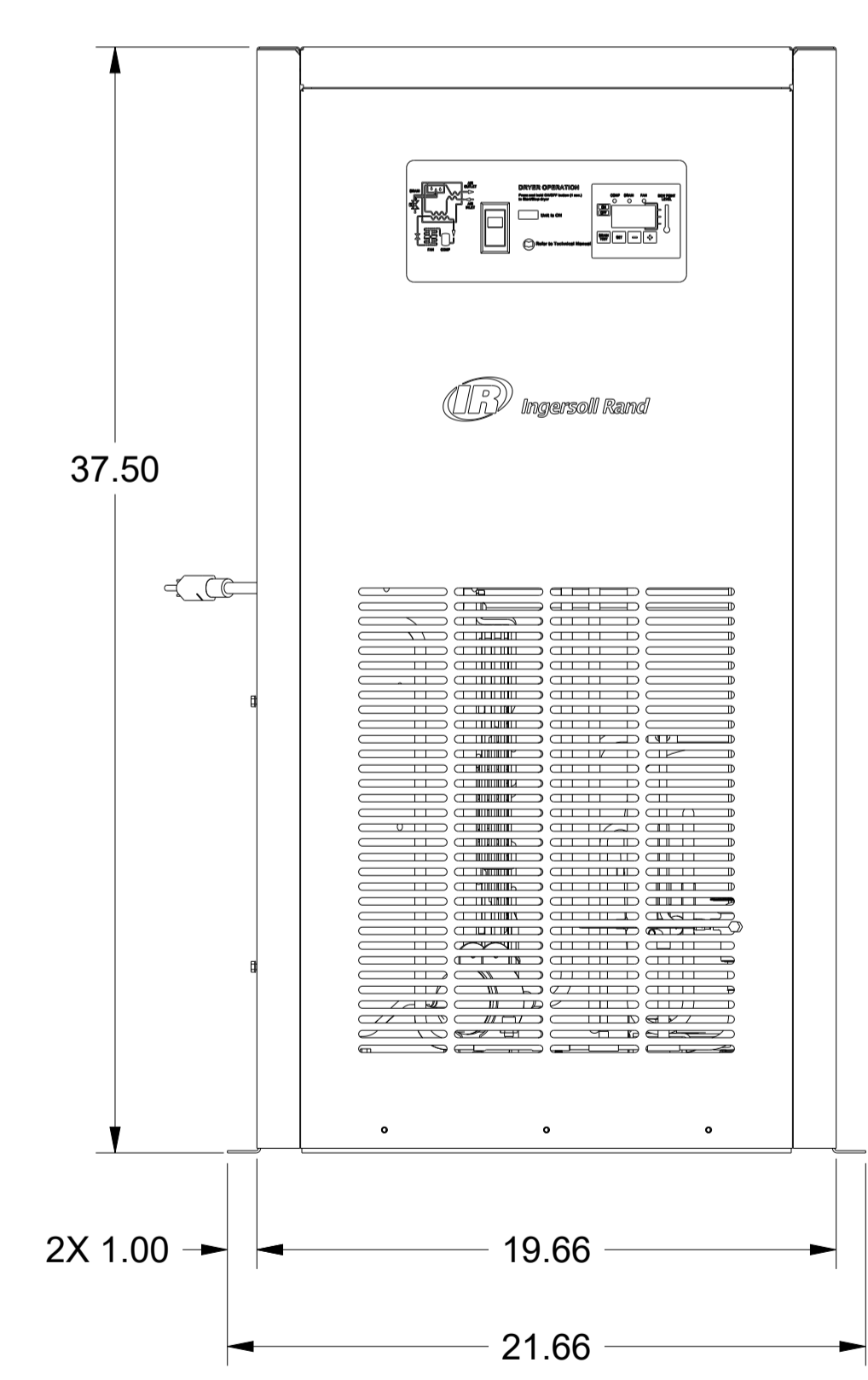
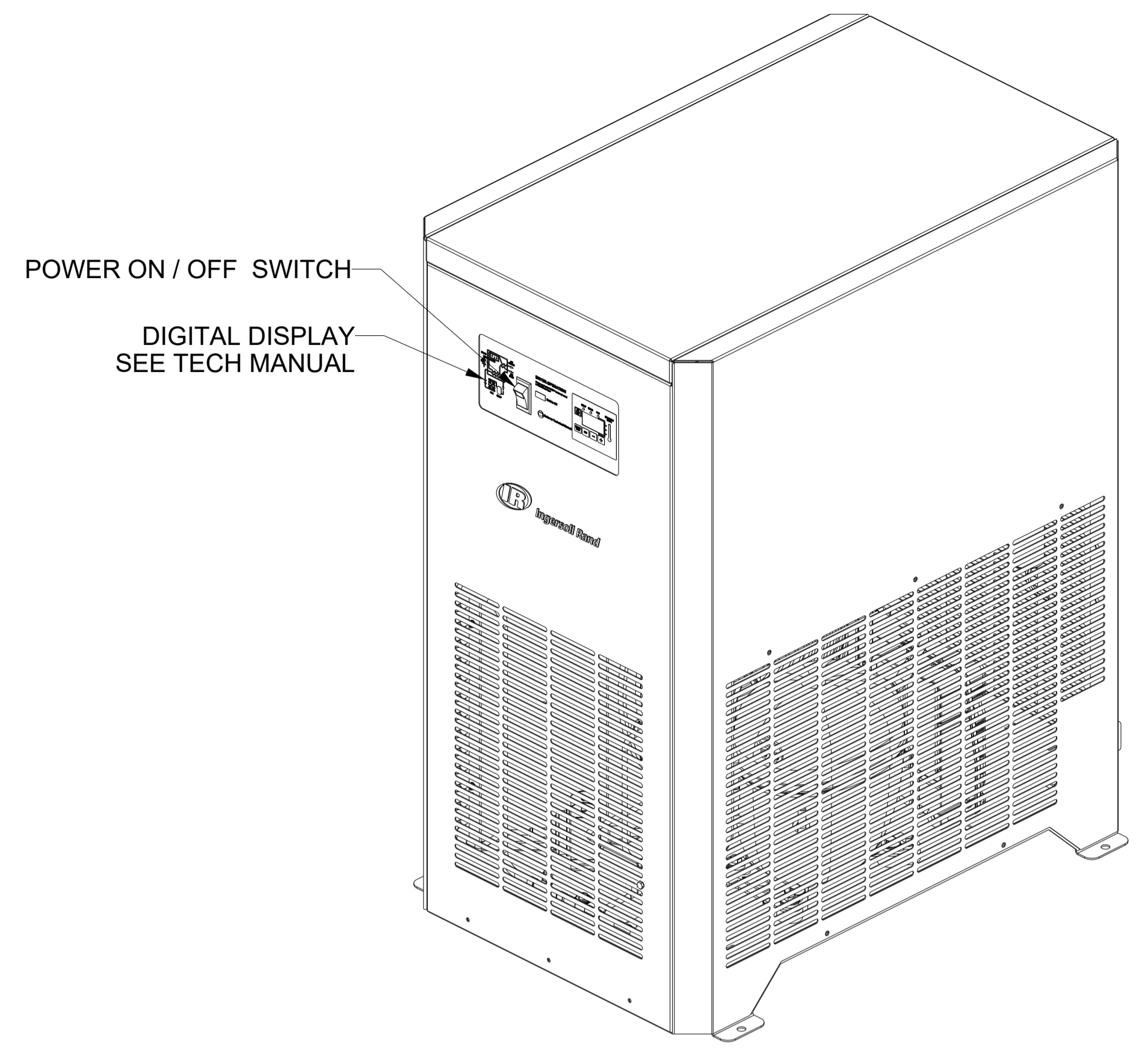
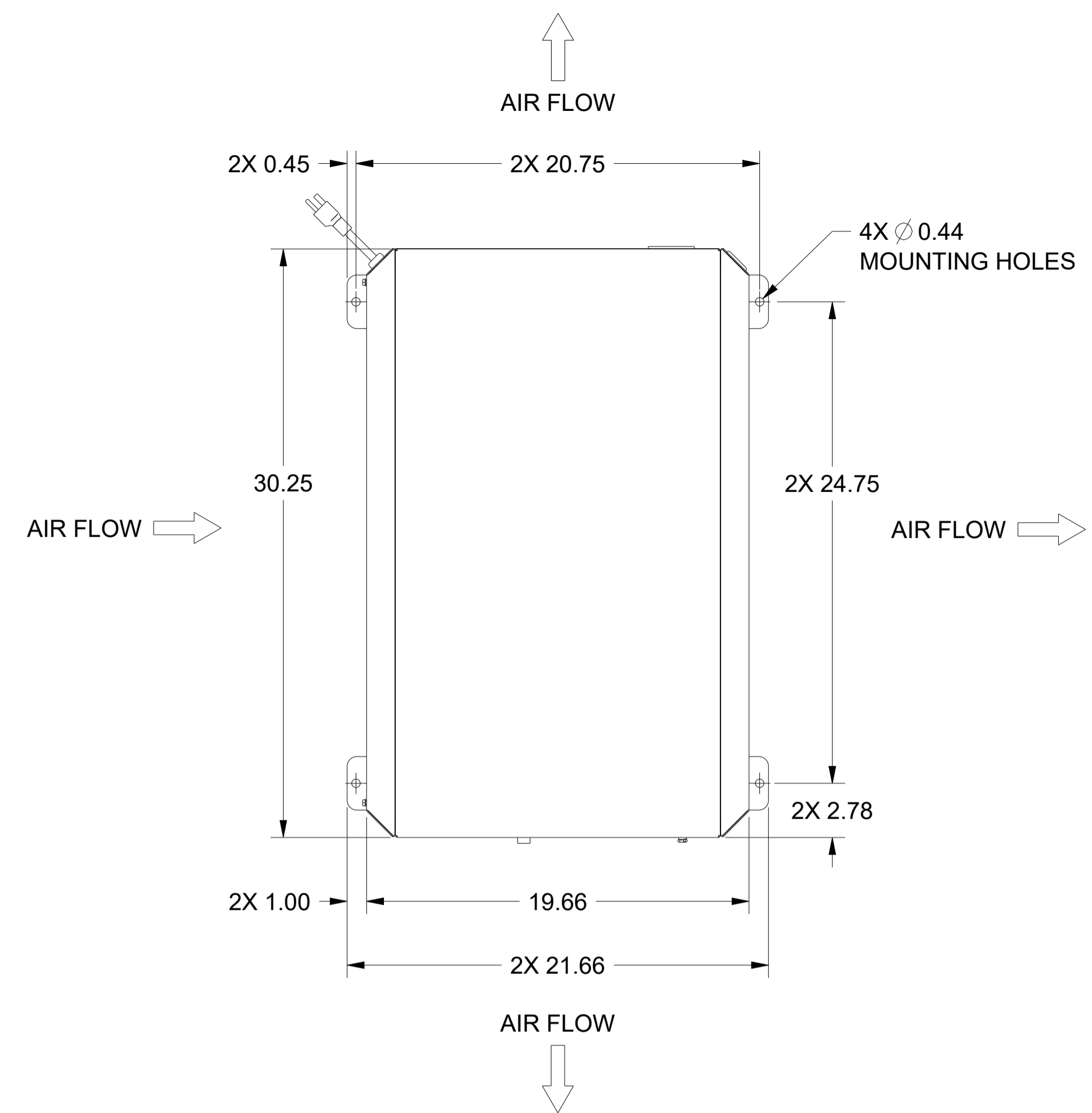

- NOTES:**
1. DRYER MUST BE POWERED BY A DEDICATED CIRCUIT.
 2. INSTALL DRAIN HOSE TO (UNPRESSURIZED) DRAIN.
 3. FULL LENGTH DRAIN HOSE NOT SHOWN FOR CLARITY.
 4. PREFILTER AND AFTERFILTER SHIP LOOSE AND ARE NOT ATTACHED TO DRYER. CUSTOMER RESPONSIBLE FOR CONNECTING PROCESS PIPING.

GENERAL ARRANGEMENT TOLERANCES

ALL DIMENSIONS ARE IN INCHES

UNSPECIFIED TOLERANCES:

X : ± .25

ANGLES : ± 1°

Ingersoll-Rand Industrial Technologies

WARNING: THE EXPORT OR REEXPORT OF THIS DRAWING OR A PRODUCT PRODUCED BY THIS DRAWING IS SUBJECT TO U.S. EXPORT ADMINISTRATION REGULATIONS & OTHER APPLICABLE GOVERNMENT RESTRICTIONS OR REGULATIONS.

Proprietary Notice: THIS DRAWING CONTAINS CONFIDENTIAL AND TRADE SECRET INFORMATION, IS THE PROPERTY OF THE COMPANY, AND IS GIVEN TO THE RECEIVER IN CONFIDENCE. THE RECEIVER BY RECEPTION AND RETENTION OF THE DRAWING ACCEPTS THE DRAWING IN CONFIDENCE AND AGREES THAT, EXCEPT AS AUTHORIZED IN WRITING BY THE COMPANY, IT WILL (1) NOT USE THE DRAWING OR ANY COPY THEREOF OR THE CONFIDENTIAL OR TRADE SECRET INFORMATION THEREIN; (2) NOT COPY THE DRAWING; (3) NOT DISCLOSE TO OTHERS EITHER THE DRAWING OR THE CONFIDENTIAL OR TRADE SECRET INFORMATION THEREIN; AND (4) UPON COMPLETION OF THE NEED TO RETAIN THE DRAWING, OR UPON DEMAND, RETURN THE DRAWING, ALL COPIES THEREOF, AND ALL MATERIAL COPIED THEREFROM.

DO NOT SCALE DRAWING
DRAWING CONFORMS TO

CAD GENERATED DRAWING,
NO MANUAL REVISIONS ALLOWED

UNLESS OTHERWISE SPECIFIED:
- REMOVE ALL BURRS AND SHARP CORNERS
- WELD SYMBOLS TO BE IN ACCORDANCE WITH ANSI/AWS A2.4

COPYRIGHT © 2025
ALL RIGHTS RESERVED

DRAWING TYPE	
General Arrangement Drawing	NOMENCLATURE

IR Ingersoll Rand

GENERAL ARRANGEMENT
DB255INA-340INA

SIZE A1	ESTIMATED WEIGHT (KG UNLESS OTHERWISE SPECIFIED)	PART NO. 47897455 001	REVISION B
SCALE	MODEL	DB255IN-340IN	SHEET 1 of 1