

REVISIONS			DATE	DRAWN	APPROVED
ZONE	REV	ECN	DESCRIPTION		
	A	1490265	ORIGINAL RELEASE	2025JAN30	B.BASAVARAJ P.NICK

- NOTES:
- PLEASE REFER TO TECHNICAL MANUAL AND ENGINEERING DATA SHEET FOR TECHNICAL DETAIL, INSTALLATION DETAIL, AND OPERATION INFORMATION.
 - UNIT INSTALLATION MUST BE ON FLAT SURFACE.
 - REFER TO MANUAL FOR CONTROLLER INFORMATION.

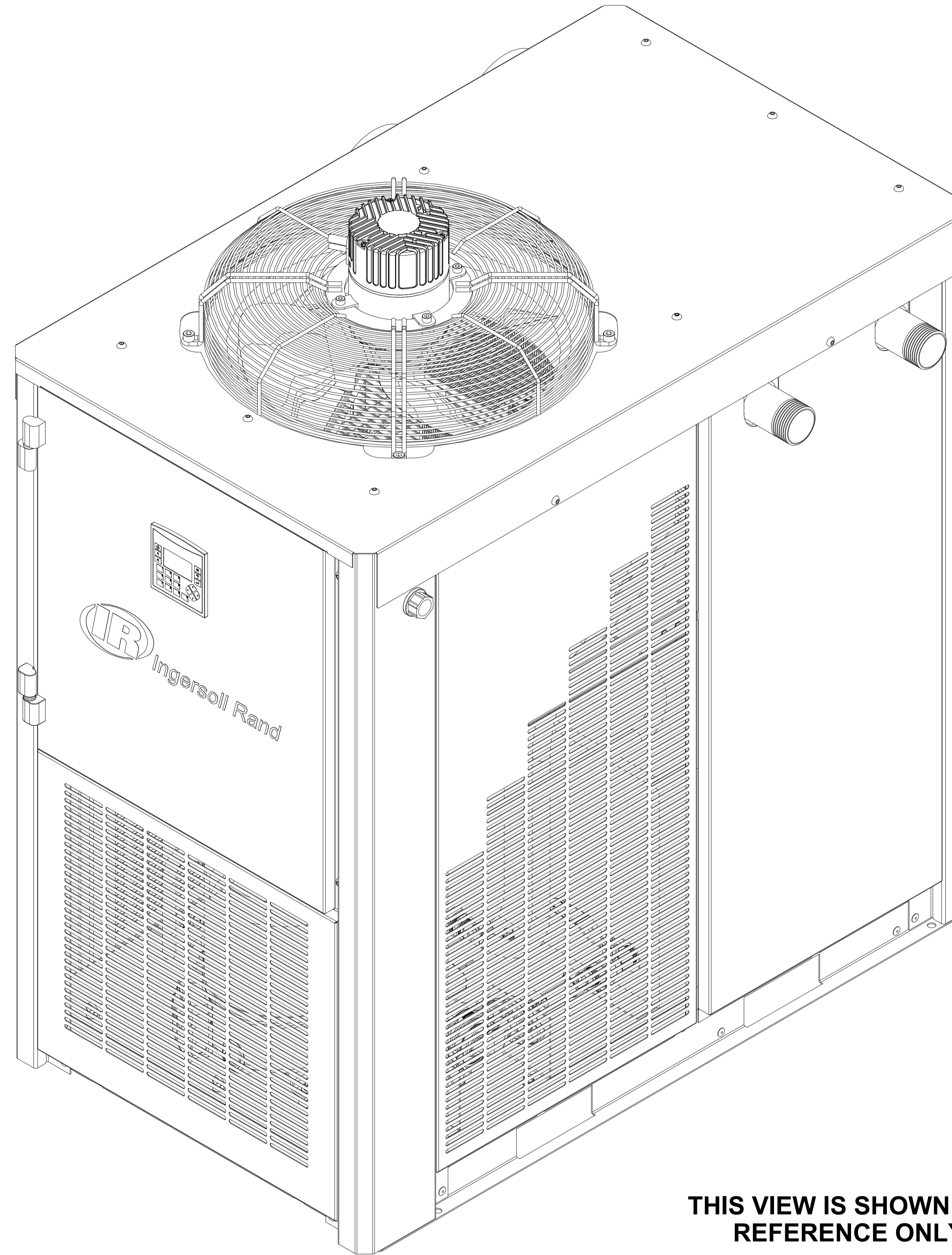

THIS VIEW IS SHOWN FOR REFERENCE ONLY

STANDARD TOLERANCES	
ALL DIMENSIONS ARE IN INCHES [MILLIMETERS (IF SHOWN)]	
UNSPECIFIED TOLERANCES:	
ONE PLACE : (.X) = N/A	
TWO PLACE : (.XX) = ± .25	
THREE PLACE : (.XXX) = N/A	
ANGLES : (.X) = ± 2.5°	
Ingersoll-Rand Industrial Solutions	

WARNING: THE EXPORT OR REEXPORT OF THIS DRAWING OR A PRODUCT PRODUCED BY THIS DRAWING IS SUBJECT TO U.S. EXPORT ADMINISTRATION REGULATIONS & OTHER APPLICABLE GOVERNMENT RESTRICTIONS OR REGULATIONS.

COMPANY: **Ingersoll Rand**

PROPRIETARY NOTICE: THIS DRAWING CONTAINS CONFIDENTIAL AND TRADE SECRET INFORMATION. IS THE PROPERTY OF THE COMPANY., AND IS GIVEN TO THE RECEIVER IN CONFIDENCE. THE RECEIVER BY RECEPTION AND RETENTION OF THE DRAWING ACCEPTS THE DRAWING IN CONFIDENCE AND AGREES THAT, EXCEPT AS AUTHORIZED IN WRITING BY THE COMPANY, IT WILL (1) NOT USE THE DRAWING OR ANY COPY THEREOF OR THE CONFIDENTIAL OR TRADE SECRET INFORMATION THEREIN; (2) NOT COPY THE DRAWING; (3) NOT DISCLOSE TO OTHERS EITHER THE DRAWING OR THE CONFIDENTIAL OR TRADE SECRET INFORMATION THEREIN; AND (4) UPON COMPLETION OF THE NEED TO RETAIN THE DRAWING, OR UPON DEMAND, RETURN THE DRAWING, ALL COPIES THEREOF, AND ALL MATERIAL COPIED THEREFROM.

DO NOT SCALE DRAWING
DRAWING CONFORMS TO ASME Y14.5M - 1994

CAD GENERATED DRAWING. NO MANUAL REVISIONS ALLOWED

UNLESS OTHERWISE SPECIFIED:
- REMOVE ALL BURRS AND SHARP CORNERS
- WELD SYMBOLS TO BE IN ACCORDANCE WITH ANSI/AWS A2.4

COPYRIGHT © 2025
ALL RIGHTS RESERVED
Ingersoll Rand

THIRD ANGLE PROJECTION	
DRAWN	DATE
B.BASAVARAJ	2025JAN30
CHECKED	DATE
P.NICK	2025JAN30
APPROVED	DATE
P.NICK	2025JAN30
DRAWING TYPE	
General Arrangement Drawing	
NOMENCLATURE	

GA DA510-680NVC, AC			
SIZE	ESTIMATED WEIGHT (NO UNLESS OTHERWISE SPECIFIED)	PART NO.	REVISION
A1	728.8 pound	47822402 001	A
SCALE	MODEL	SHEET	1 of 2
0.20	HARP IV		

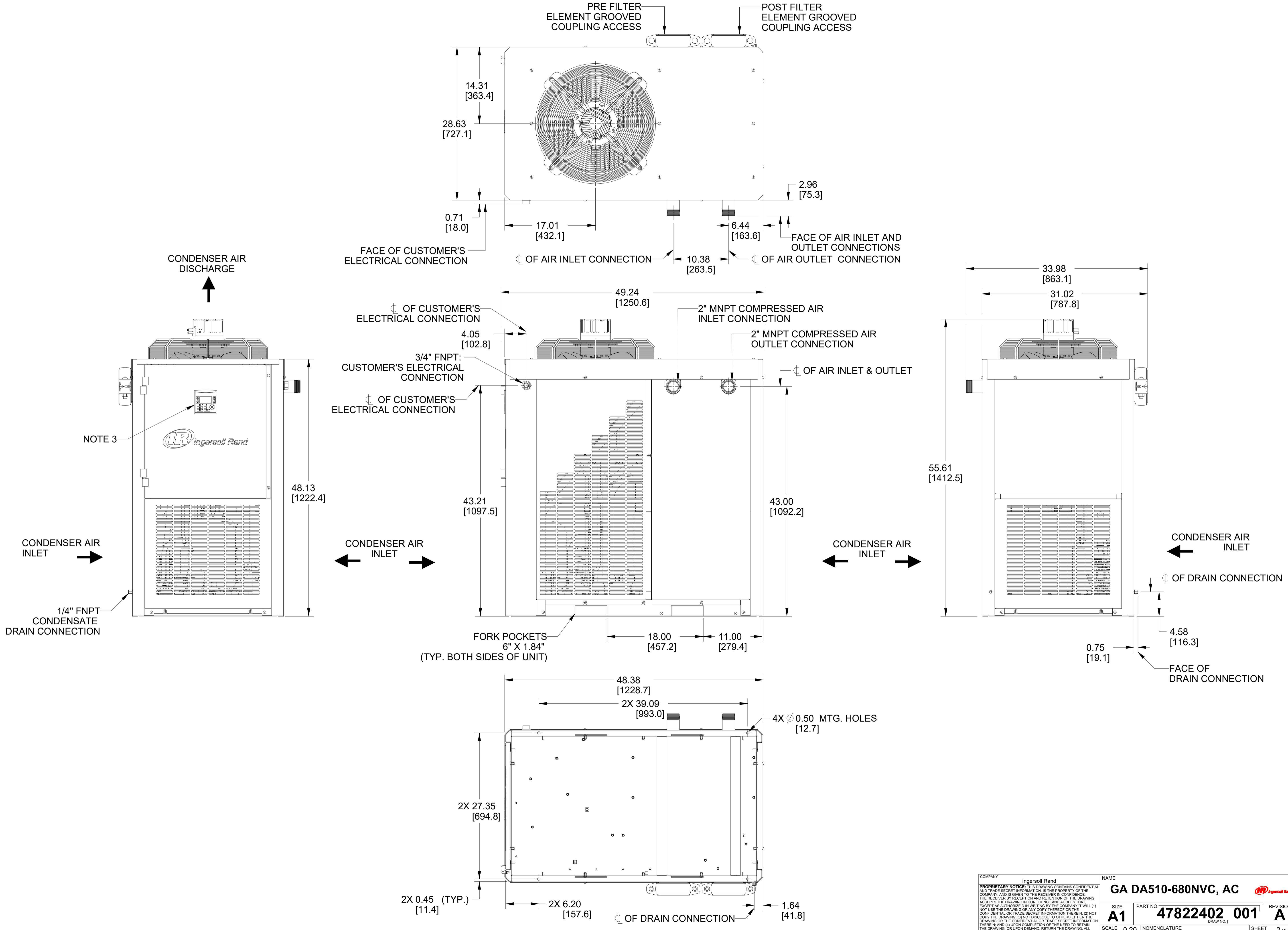

COMPANY Ingersoll Rand		NAME GA DA510-680NVC, AC	
<small>PROPRIETARY NOTICE: THIS DRAWING CONTAINS CONFIDENTIAL AND TRADE SECRET INFORMATION IS THE PROPERTY OF THE COMPANY AND IS GIVEN TO THE RECEIVER IN CONFIDENCE. THE RECEIVER BY RECEPTION AND RETENTION OF THE DRAWING ACCEPTS THE DRAWING IN CONFIDENCE AND AGREES THAT EXCEPT AS AUTHORIZED IN WRITING BY THE COMPANY IT WILL (1) NOT USE THE DRAWING OR DISCLOSE TO OTHERS EITHER THE CONFIDENTIAL OR TRADE SECRET INFORMATION THEREIN, (2) NOT COPY THE DRAWING, OR (3) DISCLOSE TO OTHERS EITHER THE DRAWING OR THE CONFIDENTIAL OR TRADE SECRET INFORMATION THEREIN. AND (4) UPON COMPLETION OF THE NEED TO RETAIN THE DRAWING OR UPON DEMAND, RETURN THE DRAWING, ALL COPIES THEREOF, AND ALL MATERIAL COPIED THEREFROM.</small>			
SIZE A1	PART NO. 47822402 001	REVISION A	
SCALE 0.20	NOMENCLATURE	SHEET 2 OF 2	