

REV	DESCRIPTION	ECN #	CHG BY	DATE	APP'D
A	UPDATED CASTING DESIGN		EZR	04/17/19	MJC

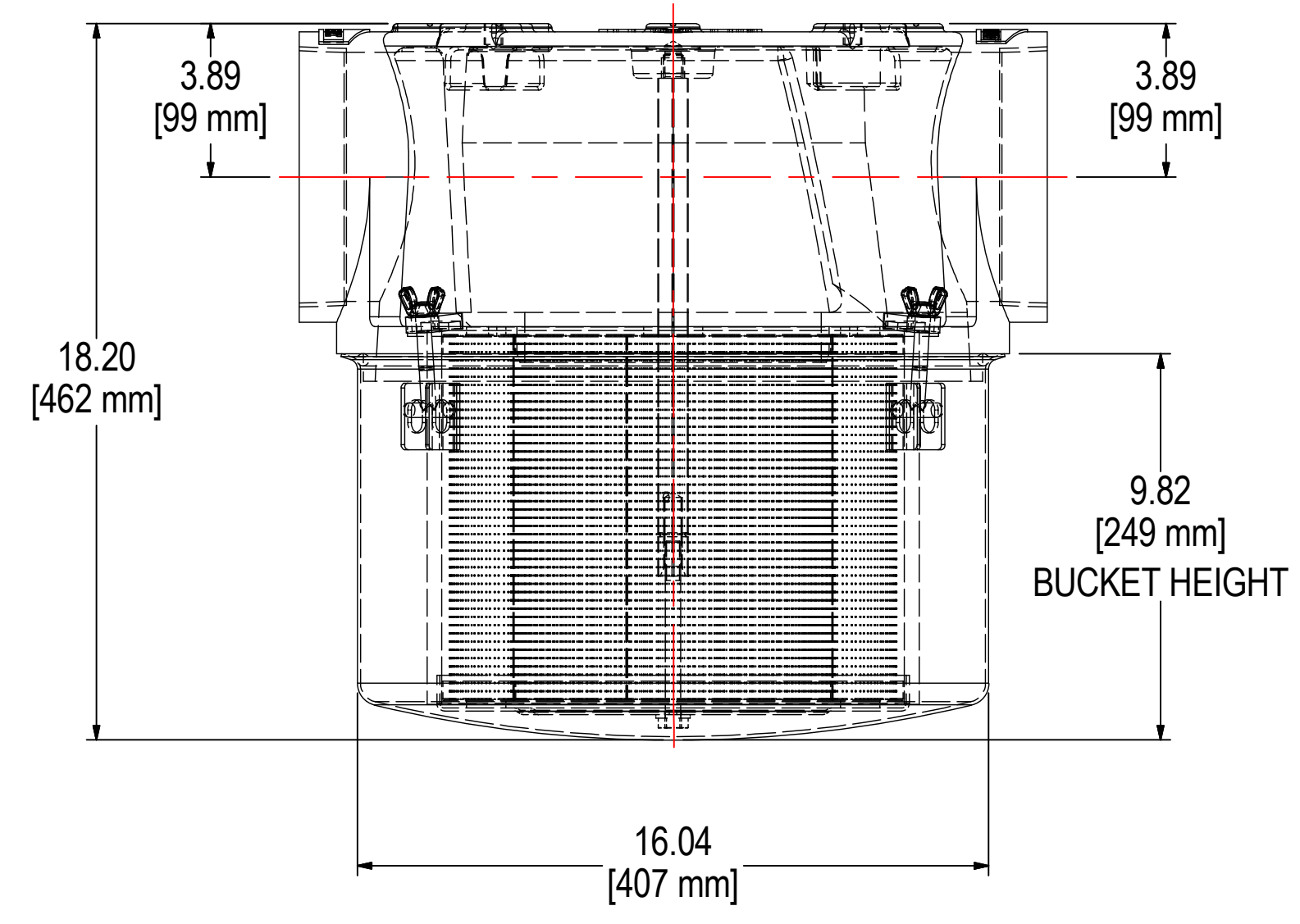
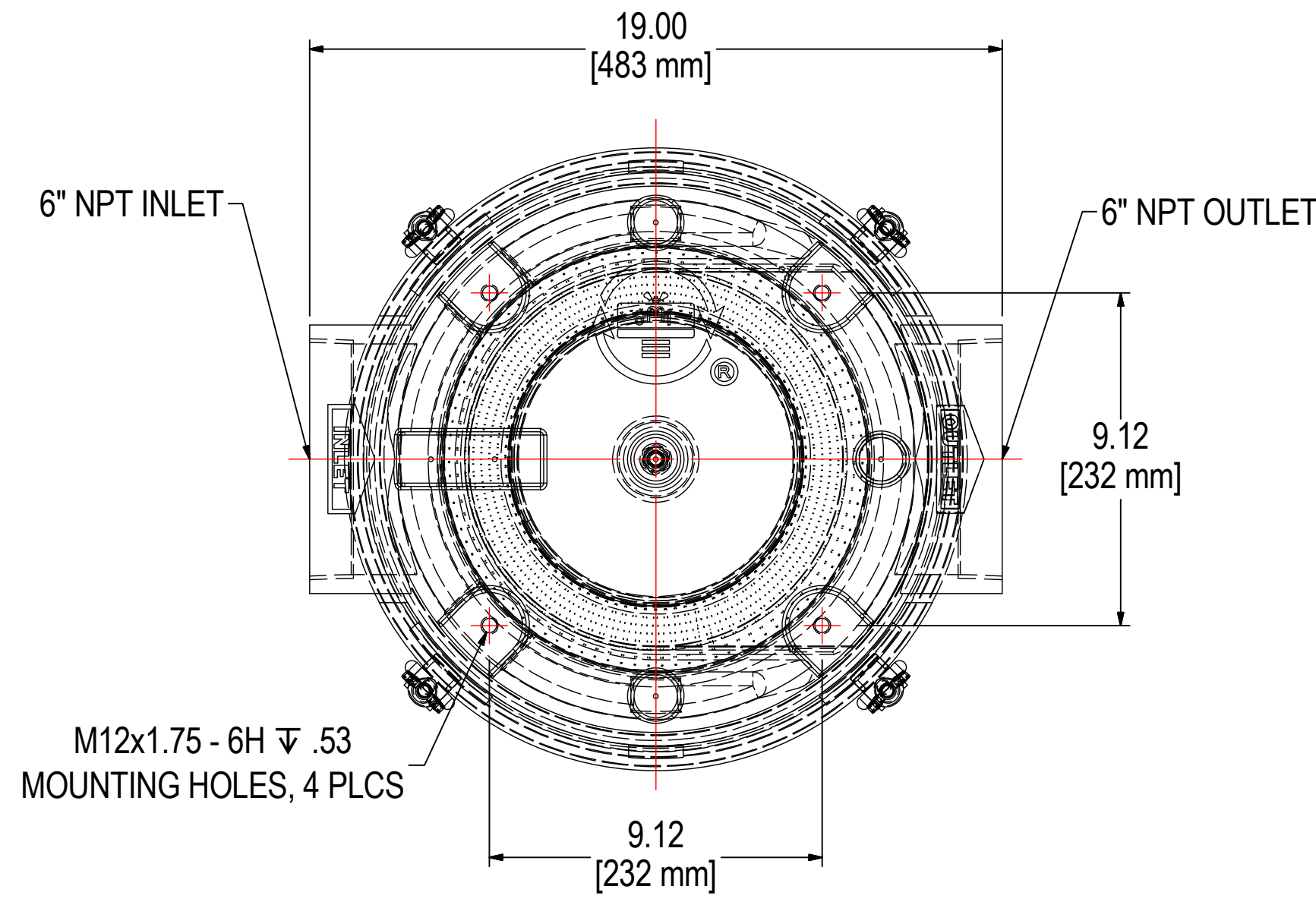

ELEMENT SPECS		
PART NUMBER	275P	
MATERIAL	Polyester	
FLOW RATE	1100 CFM	1869 m <sup>3</sup> /hr
SURFACE AREA	19.0 ft <sup>2</sup>	1.8 m <sup>2</sup>
I.D.	8.00"	203mm
O.D.	11.75"	298mm
HEIGHT	9.63"	245mm

<b>MODEL #:</b> CT-275P-600C	<b>MATERIAL:</b> CAST ALUMINUM/CARBON STEEL	<b>FINISH:</b> NONE/BLACK PAINT	<b>SHEET:</b> 1 OF 1
<b>MODEL NUMBER:</b> CT-275P-600C			
<b>DESCRIPTION:</b> CT-275P-600C, BLACK			
<b>PROJECT:</b>	<b>DRAWN BY:</b> CRW	<b>APPROVED BY:</b> M.C.	<b>REV:</b> A
	<b>DATE:</b> 3/30/2016	<b>DATE:</b> 3/30/2016	

**SOLBERG**  
Filtration • Separation • Silencing  
630.773.1363 • www.solbergmfg.com

THE INFORMATION CONTAINED HEREIN IS CONFIDENTIAL AND THE PROPERTY OF SOLBERG MANUFACTURING INC. AND IT IS FURNISHED TO YOU WITH THE EXPRESS UNDERSTANDING THAT IT WILL NOT BE REPRODUCED, COPIED IN ANY MANNER, LOANED OR OTHERWISE TRANSFERRED TO OTHERS ENTIRELY OR IN PART, NOR USED FOR ANY PURPOSE OTHER THAN FOR WHICH IT WAS FURNISHED. IT WILL BE RETURNED UPON REQUEST TO SOLBERG MANUFACTURING INC. THE ABOVE RESTRICTION IS IN ADDITION TO, AND DOES NOT IN ANY WAY ALTER, ANY OTHER RESTRICTIONS WHICH MAY APPLY TO THE INFORMATION CONTAINED HEREIN.

**TOLERANCES**  
DIMENSIONS ARE FOR REFERENCE ONLY. ALL DIMENSIONS ARE SUBJECT TO CHANGE UPON PRODUCTION.  
UNLESS OTHERWISE SPECIFIED:  
-DIMENSIONS ARE IN INCHES  
-REF: APPROXIMATE DIMENSIONS, NO TOLERANCES APPLY  
-FINISH: BREAK EDGES TO .005-.020 RADIUS/CHAMFER