



DESCRIPTION	PAGE
INTRODUCTION	2
RECEIVING & INSPECTION	
INSTALLATION	3
INSTALLATION GUIDE	4
DRYER CONTROLS	5
SAFETY SHUTDOWNS	6
START UP	
INITIAL RUN PROCEDURE	7
MAINTENANCE PROCEDURES	
HOW THE AIR DRYER WORKS	8
DESCRIPTION OF COMPONENTS	9
TROUBLE SHOOTING GUIDE	10
TECHNICAL SPECIFICATION	11-12
ELECTRICAL SCHEMATICS	13
CONTACT INFO	14

**IMPORTANT:** READ THIS MANUAL CAREFULLY. IT CONTAINS INFORMATION ABOUT SAFETY AND THE SAFETY OF OTHERS. ALSO BECOME FAMILAR WITH THE PROPER INSTALLATION AND CONTROLS OF THE AIR DRYER BEFORE OPERATING. ONLY QUALIFIED, TRAINED AND LISCENSED PERSONAL SHOULD SERVICE OR OPERATE THIS EQUIPMENT. RECORD THE INFORMATION BELOW AND SAVE THIS MANUAL. IF SERVICE IS NEEDED THE INFORMATION BELOW WILL BE NEEDED.

**CAUTION:** THIS MACHINE CONTAINS HIGH PRESSURE GAS AND ELECTRICITY.

**NOTE:** Please record the information below and keep this manual. If you need service on this dryer you will need this information.

Use [QR Code](#) to register your new Attec AIR Refrigerated Air Dryer

Model # \_\_\_\_\_  
 Serial # \_\_\_\_\_  
 Voltage \_\_\_\_\_

Purchased from: \_\_\_\_\_



## **INTRODUCTION**

Thank you for selecting an DX Series energy savings refrigerated air dryer from Altec AIR.

The refrigerated air dryer is specifically designed and manufactured for drying and purifying compressed air generated by an air compressor.

Please read this instruction manual carefully before using the air dryer and pay attention to the precautions in transportation, installation and operation that are listed in this manual.

Please use the dryer according to our application guide and be sure to perform the proper preventative maintenance as recommended in this manual. Failure to perform the preventative maintenance will void the air dryer warranty.

Refrigeration used in this air dryer is environmentally friendly R134a or R404a and is available at local refrigeration wholesalers.

Direct any questions not covered in this manual to your distributor or call Altec AIR @ 1-800-521-5351. Before calling with questions always have the air dryer model #, serial # and pressure gauge readings.

Service and maintenance can be obtained from your distributor. If you do not know your distributor please contact the factory. Authorization must be obtained from Altec AIR before any parts or dryers are returned to the factory. Altec AIR will not be responsible for anything returned without authorization.

## **RECEIVING AND INSPECTION**

**The dryer cannot be tilted on its side or upside down during shipping.**

**Use forklift from the bottom of the dryer when installing or moving.**

- Dryers are shipped F.O.B. factory. Immediately upon arrival check the dryer for possible damage. If damage is found, report it to the carrier and file a damage claim. Check dryer data label to be sure you have the right dryer. Check the data labels voltage and amperage to be sure it is correct and the one you ordered. Check the refrigeration gauges for pressure.

**If the gauges read 0 PSIG, STOP.**

- Do not start the dryer. Contact Altec AIR or your local distributor for service. This could mean there is a leak in the refrigeration system.

### **Data Label**

- The data label is affixed to the outside of the cabinet.
- This label identifies the air dryer's model and serial numbers and important technical data.
- Before installing the dryer check all of the information on the data label for the correct model and voltage.

**If the model number and voltage are incorrect do not install or power ON the dryer.**

**Contact Altec AIR or your local distributor immediately.**

DATA LABEL	
Model	UA200A-2
Serial #	
Date of MFG.	1/8/2016
Voltage	230v-1ph-60hz
Voltage Range	253-187
RLA	7
LRA	41
Min Circuit Ampacity	9.9
Max Fuse Size	15
Maximum Inlet Air Temp - F	110
Min/Max. Ambient Temp - F	110/45
Ref. System Design - PSI	350/150
Suction/Discharge - PSI	30/120
Maximum Pressure (PSIG)	232
Ref. Compressor HP	1
Refrigerant Type	R134A
Refrigerant Charge	CF
MADE IN USA	
DISCONNECT POWER SUPPLY BEFORE SERVICING	

## **INSTALLATION**

### **DRYER LOCATION / VENTILATION**

Install dryer only in a well-ventilated, clean, dry area and keep at least 3 feet between the dryer, other equipment and the walls. Dust and dirt particles will clog the air-cooled condenser and will reduce the performance of the dryer and will eventually cause damage to it.

Do not install the dryer outside. The air dryer must not be exposed to direct sunlight, rain or snow.

### **AMBIENT TEMPERATURES**

Suitable ambient temperature for the refrigerant dryer is a MIN of 45°F to a Max of 110°F. The performance of the dryer will be significantly decreased when the air dryer is subject to temperatures higher than 110°F.

For installations with ambient temperatures higher than 110°F it is recommended to use a water-cooled condenser on the dryer. Contact Altec AIR or your local distributor for details

### **INLET & OUTLET CONNECTIONS**

Do not mix the air inlet and outlet air flow. Pipe diameter should be sized according to air flow requirements. It is recommended that a vibration absorber be installed on the dryer inlet and outlet to eliminate vibration from the compressor. Do not use the inlet and outlet of the air dryer to support the weight of the air piping.

### **FILTRATION, BYPASS VALVES, & CONDENSATE DRAINS**

Appropriate pre and post filtration should be installed to protect the air dryer as well as the compressed air system.

Isolation or 3-valve bypass should be installed on the air dryer outlet and inlet ports to allow for bypassing, depressurizing, proper maintenance, and servicing of the air dryer.

Condensate drains must be properly piped from the dryer to prevent moisture re-entrainment. The dryer is equipped with an automatic drain valve that controls the discharge of the condensate. The user must run a drain line to an environmentally approved condensate collection/disposal system.

### **ELECTRICAL INSTALLATION**

The dryer Data Label lists the electrical power requirements for the air dryer. The user must confirm that the line voltage matches the voltage listed on the data label. (Warning – Operating the air dryer with improper line voltage will void the warranty). Provide the proper size wire, disconnect switches and fuses in accordance with applicable codes. Field wiring must comply with local and national fire safety and electrical codes. Standard dryer's enclosures and controls are designed to meet NEMA 1 Type 1 electrical standards.

Connect power leads as indicated in the electrical schematic. Ground the frame properly.

**IMPORTANT NOTE:** DX series dryers that are 460v-3ph-60hz and 230v-3ph-60hz voltages have Scroll Refrigerant Compressors. These compressors must be wired for proper rotation with the proper phases L1, L2, L3. To check if dryer is wired properly turn dryer on and observe the REFRIGERANT SUCTION PRESSURE GAUGE, immediately after the dryer is switched ON the pressure on this gauge should drop. If after 30-45 seconds the pressure does not drop switch the dryer OFF. This could mean the dryer is wired wrong. Switch any 2 leads and repeat.

**MAXIMUM WORKING PRESSURE** - 232 psig.

### **BREATHING AIR APPLICATIONS**

This dryer has not been tested for breathing air applications. The owner is advised to do its own testing and use for breathing air applications at own's risk.

# **INSTALLATION GUIDE**

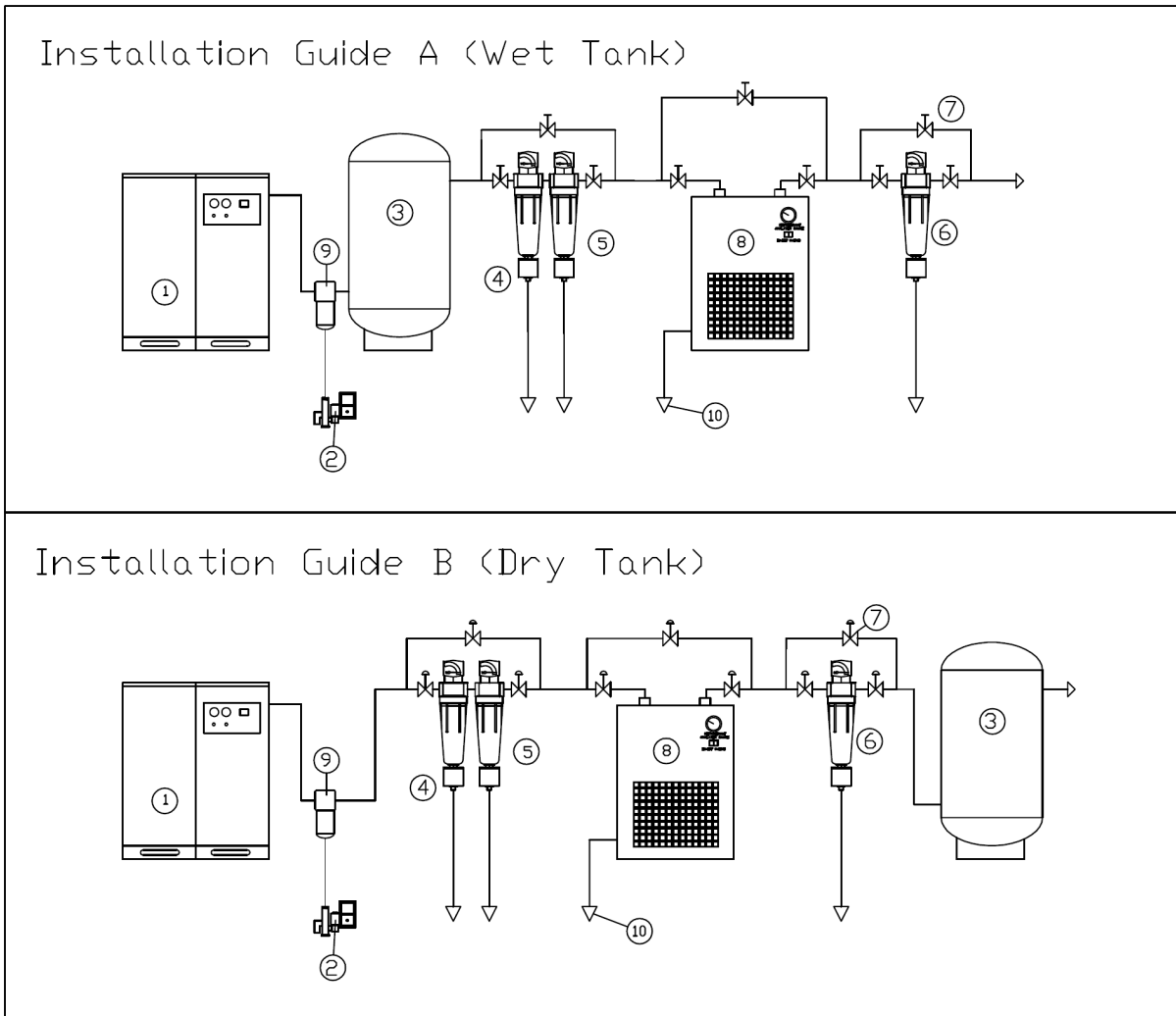

- (1) Air Compressor
- (2) ADF Series Drain Valve
- (3) Air Receiver Tank
- (4) AC Series X5 Pre-filter
- (5) AC Series X1 Pre-filter

- (6) AC Series XA After filter
- (7) 3 Valve Bypass
- (8) DX Series Air Dryer
- (9) AW Series Water Separator
- (10) Centrifugal separator

INSTALLATION A: Recommended for systems that consume less than or equal to the maximum capacity of the air compressor.

INSTALLATION B: Recommended for systems that consume more than the maximum capacity of the air compressor.

## DRYER CONTROLS

### CLD CONTROLLER

Is a closed-loop digital controller that precisely monitors the refrigeration system high side and low side pressures, cycles the condenser fan motors on and off, loads and unloads the digital scroll compressor based on the current heat load (Air flow) going through the dryer.

- Refrigerant Suction Pressure readout
- Refrigerant Discharge Pressure readout
- Condenser fan ON/ OFF indicators

NOTE: The CLD controller is pre-set at the factory. No adjustments are necessary or should be made.

UPPER DISPLAY	LOWER DISPLAY	ICONS
Suction temperature or pressure	Discharge temperature or pressure	-Active loads -Measurement unit



Figure 6 – Controller Display

Table 5 – Icon Legend

LED	FUNCTION	MEANING
°C	ON	Celsius degrees
°F	ON	Fahrenheit degrees
bar	ON	bar displaying
PSI	ON	PSI displaying
kPa	ON	KPA displaying
[1]	ON	Copeland Scroll Digital compressor on
[1]	Flashing	Digital compressor is waiting to start (flash once per second) or digital input alarm for DIGITAL COMPRESSOR (flash twice per second) or DIGITAL COMPRESSOR in maintenance status.
[2]	ON	Compressor 2 on
[2]	Flashing	Compressor 2 is waiting to start (flash once per second)
[3]	ON	Fan 1 on
[3]	Flashing	Fan 1 is waiting to start (flash once per second)
[4]	ON	Fan 2 on
[4]	Flashing	Fan 2 is waiting to start (flash once per second)
[⊞]	ON	The digital solenoid valve coil is energized

## **SAFETY SHUTDOWNS**

### **HOW TO MAKE MINOR REFRIGERANT SUCTION PRESSURE ADJUSTMENTS**

Keep dryer running under a no load by turning off or bypassing the compressed air.

Remove dryer top and locate the Hot Gas Bypass Valve. Remove cap on Hot Gas Bypass Valve and using an Allen wrench turn valve counter clockwise to decrease the suction pressure and clockwise to increase the suction pressure.

Make ½ turn adjustments and wait 2 to 3 minutes for suction pressure to stabilize. Make more adjustments if needed.



### **HIGH PRESSURE SHUTDOWN WITH MANUAL RESET**

Shuts the dryer down in the event of a dirty condenser, fan motor failure or excessively high ambient temperatures (Installed on UA150/MHT100 and above)

### **LOW PRESSURE SHUTDOWN**

Shuts the dryer down in the event of low ambient conditions or if there is a leak in the refrigeration system.



### **INTERNAL OVERLOAD**

The internal overload is a bi-metal switch that will open and stop the compressor if the temperature of the compressor is too high. The switch will re-set itself when the compressor cools to a lower temperature.

## **START UP**

The following procedure must be followed to start your air dryer. Failure to follow this start up procedure will void your warranty. If problems occur during start up, contact Altec AIR or your local distributor.

1. Turn the ON/OFF switch to the OFF position.
2. Verify the main electrical supply voltage matches the voltage specified on the data label.
3. Check the proper connection and support of the compressed air lines to the dryer: check dryer bypass and isolation valve system.
4. Confirm that the inlet and ambient air temperature, pressure and flow to the dryer meet the specified requirements.
5. Confirm that the condensate drain lines from the separator are properly piped to an environmentally approved disposal system
6. Check the refrigeration pressure on the Suction Pressure Gauge. If pressure is at 0 psig, DO NOT attempt to start the dryer. Call Altec AIR or your local distributor for assistance.

## **INITIAL RUN PROCEDURE**

After start up and checks are complete and after the main electrical power to the dryer has been connected, follow the procedure below to put the dryer in operation:

1. Turn ON the dryer ON/OFF switch.
2. Let the dryer run for 15 minutes.  
IMPORTANT NOTE: All 230/460/575 VAC, 3 Phase motors MUST be wired for proper rotation. After the air dryer is turned ON, the suction pressure should DECREASE (pull down) instantly. If the suction pressure does not pull down TURN OFF THE AIR DRYER IMMEDIATELY and contact your local distributor or Altec AIR for assistance
3. Check the Refrigerant Suction Pressure Gauge: (65 psig to 90 psig) Pressures will fluctuate due to loading and unloading of the digital scroll compressor.
4. Check the Refrigerant Discharge Pressure Gauge: (170 psig to 270 psig) Pressures will fluctuate due to loading and unloading of the digital scroll compressor.
5. Check the Dewpoint Temperature Indicator. After 15 min, the indicator should read 35F to 39F.
6. Slowly, allow compressed air to flow through the dryer.
7. Confirm that condensate is discharging from the condensate drain. This may take 30-60 minutes.
8. Make sure bypass valves are closed and 100% of the air from the compressor is flowing through the dryer.

## **HOW TO SET THE CONDENSATE DRAIN OPEN & CLOSED TIME**

The OPEN (ON) time is adjustable from 0.5 sec to 10 sec. Drains are set at factory to open for 6 sec. When drain opens the on light will light. Push the TEST button to manually open the drain valve.

The CLOSED (OFF) time is adjustable 0.5 min to 45 min. Drains are set at factory to stay closed for 10 min. When drain is closed the off light will light. You may increase or decrease this based on moisture levels in the air.

### TO CLEAN VALVE

1. Close isolation valve
2. Push the push to test button to release the pressure
3. Remove strainer/filter and screen.
4. Clean screen and replace.

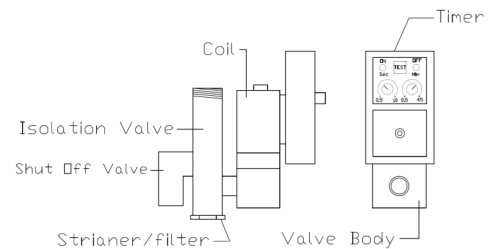

## **MAINTENANCE PROCEDURES**

### **Weekly Maintenance (or as Required)**

- Check the operation of the automatic drain valves at least once during each eight hour shift.
- Check Dew point Indicator to make sure it is the proper range. (UA10 to UA55 & MHT25)
- Check Suction Pressure Gauge to make sure it is the proper range. (UA75/MHT40 and larger)
- Check Discharge Pressure Gauge to make sure it is the proper range. (UA400/MHT200 and larger)
- Make sure condenser coil is clean and unobstructed. Clean Air Cooled Condenser Coil if necessary.  
**WARNING** - DRYER FAILURE DUE TO A DIRTY CONDENSER IS NOT COVERED UNDER WARRANTY

### **Monthly Maintenance**

- Clean Air Cooled Condenser Coils - Blow off all dust and dirt that is on the condenser with a compressed air maintenance gun. While cleaning the condenser fins do not damage fins.
- Clean Automatic Drain Valve - Close Isolation Valve; Push the Test Button to release the pressure; Remove strainer/filter and screen; Clean screen and replace.
- Check Compressed Air Filter Differential - Replace Elements if necessary

### **Yearly Maintenance**

- Replace Elements of Pre and Post Filtration - Replace per Filter Instructions annually or as required due to high differential.



## **HOW THE AIR DRYER WORKS - DX SERIES**

The DX Series air dryer featuring a digital scroll refrigeration compressor and capacity modulation control is the only type of air dryer that will respond during periods of lower compressed air usage by unloading the refrigeration compressor thereby reducing the power consumption of the dryer down to 10% of its typical full power (watts) running requirements.

The beauty of this technology is its inherent simplicity. The standard Scroll has a unique feature called axial compliance. This allows the fixed scroll to move slightly in the axial direction to ensure that the fixed and orbiting scrolls are always engaged together with the optimal force. This optimal force, which holds the two Scrolls together at all operating conditions, ensures high efficiency of Scroll.

The Digital Scroll operation builds on this principle. A piston is fixed to the top scroll to ensure that when the piston moves up, the top scroll also moves up. There is a modulation chamber at the top of the piston that is connected to the discharge pressure through a bleed hole of diameter 0.6 mm.

An external solenoid valve connects the modulation chamber with the suction side pressure. When the solenoid valve is in the closed position, the pressure on either side of the piston is discharged and a spring force ensures that the two scrolls are loaded together. When the solenoid valve is energized, the discharge gas in the modulation chamber is relieved to the low pressure. This causes the piston to move up and consequently the top scroll also moves up. This action separates the scrolls and results in no mass flow through the scrolls.

At this point the power consumption is reduced by 90%. De-energizing the external solenoid valve again loads the compressor fully and the compression is resumed.

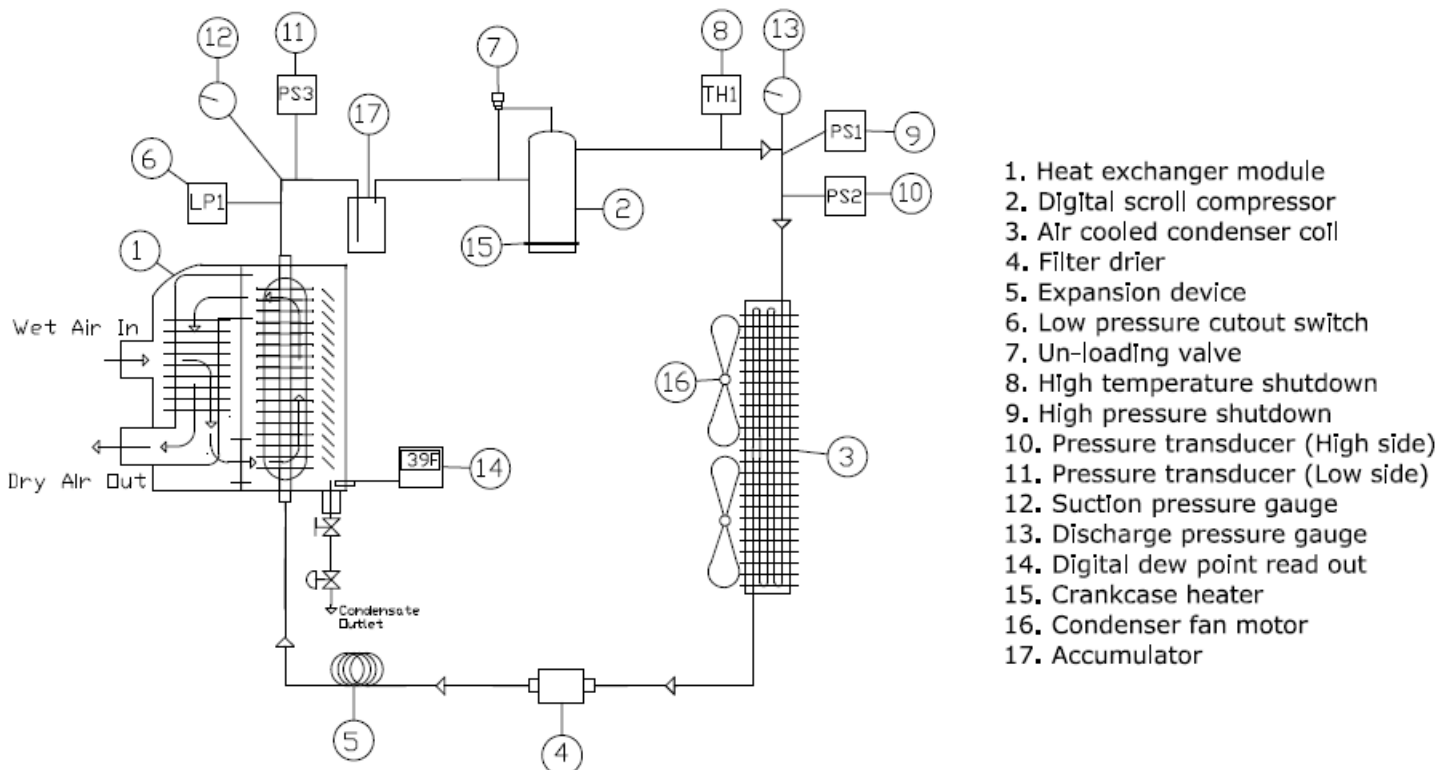



## **DESCRIPTION OF COMPONENTS - DX SERIES**

- 1. HEAT EXCHANGER MODULE:** The compact aluminum module contains the air to air heat exchanger the air to refrigerant heat exchanger and the moisture separator
- 2. DIGITAL SCROLL REFRIGERANT COMPRESSOR:** The main function of the compressor is to circulate the refrigerant. The compressor pumps refrigerant to the other components in the system so they can perform heat transfer functions. The compressor also separates the high pressure from the low pressure side of the refrigeration system.
- 3. AIR-COOLED CONDENSER:** One of the main functions of the condenser is to condense the high pressure and high temp refrigerant vapor to liquid. A heavy duty fan moves ambient air across the condenser coils removing heat from the refrigerant vapor. As the heat is removed the refrigerant vapor the temperature change causes the refrigerant to change state from a vapor to a liquid. The condenser is made from aluminum fins attached to copper tubes.
- 4. FLTER-DRIER:** Adsorbs and filters out any moisture or debris that maybe in the refrigeration system. Moisture can cause freeze ups and dirt particles can plug capillary tubes causing system malfunctions.
- 5. EXPANSION DEVICE:** The metering device meters liquid refrigerant from the liquid line to the evaporator. The capillary tube is a restriction that separates the high pressure side from the low pressure side in the refrigeration system.
- 6. LP1 - LOW PRESSURE SAFETY CUT OUT –** Prevents damage to the refrigerant compressor in the event of a refrigerant leak or low refrigerant pressure.
- 7. UN-LOADING VALVE –** respond to changes in suction pressure. As the air flow (Or heat load) on the dryer changes the suction pressure will change. An increase in air flow causes an increase in suction pressure a decrease in air flow causes a decrease in suction pressure. During periods of low air flow the HGBV meters hot gas from the hot gas line of the high side to the inlet of the air to ref
- 8. (TH1) HIGH TEMPERATURE SHUTDOWN:** Shuts off compressor if discharge gas temperature exceeds 290°F.
- 9. (PS1)HIGH PRESSURE SAFETY SHUTDOWN w/MANUAL RESET:** Prevents damage to the refrigerant compressor and other components in the event of high refrigerant pressure due to fan motor failure, dirty condenser or over capacity. CUT OUT: (R404A 405 PSIG)
- 10. (PS2)PRESSURE TRANSDUCER(HIGH SIDE):** Cycles the condenser fan motor on and off to maintain the proper condensing pressure dryer periods of fluctuating loads and ambient conditions. Fan#1 On 170psig, Fan #2 On 270 psig.
- 11. (PS3)PRESSURE TRANSDUCER(LOW SIDE):** Monitors evaporator pressure. Set to maintain an average 70 psig evaporator pressure. Under low loads the evaporator pressure will drop below 70 psig. The CLD controller will open the un-loading valve and stop the scroll compressor from pumping. When the suction pressure increases the valve will close and the compressor will resume pumping.
- 12. SUCTION PRESSURE GAUGE:** Continuously monitors the refrigerant suction or low side refrigeration system pressure. The suction pressure will fluctuate between 60 and 90 psig as the un-loading valve opens and closes. DX series dryers use R404a
- 13. REFRIGERATION DISCHARGE PRESSURE:** Continuously monitors the refrigerant discharge or high side pressure. The Discharge pressure will fluctuate between 170 and 270 psig.
- 14. DIGITAL DEWPOINT READOUT:** Continually monitors the lowest air temperature or dew point air temperature of the compressed air in the heat exchanger module.
- 15. DIGITAL SCROLL REFRIGERANT COMPRESSOR:** Semi – hermetic compressor continually pumps refrigerant through the refrigerant circuit.
- 16. CONDENSER FAN MOTORS:** Drives ambient air over condenser coils. Fan motors will cycle on and off based on the high side refrigeration pressure. One fan cycles on at 170 psig the other cycles on at 270 psig.

## **TROUBLE SHOOTING GUIDE**

<b>Problem</b>	<b>Cause</b>	<b>Solution</b>
Excessive pressure loss in system	Bypass valve not completely open	Open completely
	Pipe diameter too small	Increase diameter
	Piping system has too many tie ins	Redesign pipe system
	Leaks in piping system	Fix leaks
	In line filter element clogged	Replace filter element.
Water downstream of dryer	Bypass valve not completely closed	Close bypass valve
	Air not going through dryer	Open inlet valve completely
	Under high flow conditions pressure drops significantly	Redesign compressed air source and check pipe diameter.
	Auto drain plugged or not working.	Clean drain or replace
	Dryer too small for inlet air flow	Replace dryer or reduce inlet flow.
	No pre filter in system	Install pre filter
Evaporator pressure is too high or too low.	Inlet air temp is too high	Check air compressor after cooler
	Air cooled condenser is clogged	Clean condenser
	Expansion valve is defective	Replace expansion valve
	Refrigerant leak	Find leak and fix. Add refrigerant
	Pressure gauge is bad	Replace with new gauge
	Hot gas bypass needs adjusting	Adjust valve to correct pressure.
Power is on to the dryer but the dryer will not start	Fuse is bad	Check for short, fix and replace fuse
	On/Off switch defective	Replace switch
	No power going to dryer	Check circuit breaker and power supply
	Power going to dryer is incorrect	Make sure power source and data label match.
	Contactors defective	Replace with a new one
	Over load relay defective	Replace with a new one
	Capacitor defective	Replace with a new one
	Start relay defective	Replace with a new one
	Pressure switch defective	Replace with a new one
	Temp switch defective	Replace with a new one
	Compressor defective	Replace with a new one
	High Pressure switch is open	Find reason and reset
	Low pressure switch is open	Find reason and reset
Thermostat open	Find reason and reset	
Evaporator Temp is too low	Hot gas bypass valve needs adjusting	Adjust or replace
	Evaporator pressure gauge bad	Replace
	Capillary tube blocked	Replace
	Temp or Pressure reset set to low	Reset
	Refrigerant leak	Find leak, fix it and add refrigerant
Evaporator Temp is too high	Ambient temp too high	Improve ventilation in area
	Hot Gas valve needs adjusting	Adjust or replace
	Condenser blocked or plugged	Clean condenser
	Flow is too high going in dryer	Change air compressor
	Compressor valves are damaged	Replace compressor

# TECHNICAL SPECIFICATIONS

SPECIFICATIONS	DX400A	DX500A	DX625A	DX800A	DX1000A	DX1200A	DX1600A	DX2000A
<b>CAPACITY (SCFM)</b>	400	500	625	800	1000	1200	1600	2000
<b>Inlet/Outlet Connection (NPT)</b>	2" NPT	2" NPT	2-1/2" NPT	3" NPT	3" NPT	3" NPT	4" NPT	4" NPT
<b>MIN/MAX INLET AIR PRESSURE</b>	0/232	0/232	0/232	0/232	0/232	0/232	0/232	0/232
<b>MIN/MAX AMBIENT TEMP</b>	35/110°F	35/110°F	35/110°F	35/110°F	35/110°F	35/110°F	35/110°F	35/110°F
<b>MAX. INLET TEMP</b>	110°F	110°F	110°F	110°F	110°F	110°F	110°F	110°F
<b>VOLTAGE (STANDARD)</b>	460V-3PH-60HZ	460V-3PH-60HZ	460V-3PH-60HZ	460V-3PH-60HZ	460V-3PH-60HZ	460V-3PH-60HZ	460V-3PH-60HZ	460V-3PH-60HZ
<b>VOLTAGE RANGE</b>	414-506	414-506	414-506	414-506	414-506	414-506	414-506	414-506
<b>REF. COMP. HP</b>	2	3	3	4	5	6	8	10
<b>RLA</b>	6.5	7.1	7.1	7.9	11	11	29	30
<b>LRA</b>	38	39	39	46	75	75	95	150
<b>MAX FUSE SIZE</b>	15	15	15	15	15	30	30	30
<b>REFRIGERANT TYPE</b>	R404a	R404A	R404A	R404A	R404A	R404A	R404A	R404A
<b>REFRIGERANT QTY.</b>	CF	CF	CF	CF	CF	CF	CF	CF
<b>SHIPPING WGT. (LBS)</b>	486	510	530	855	865	900	1400	1595

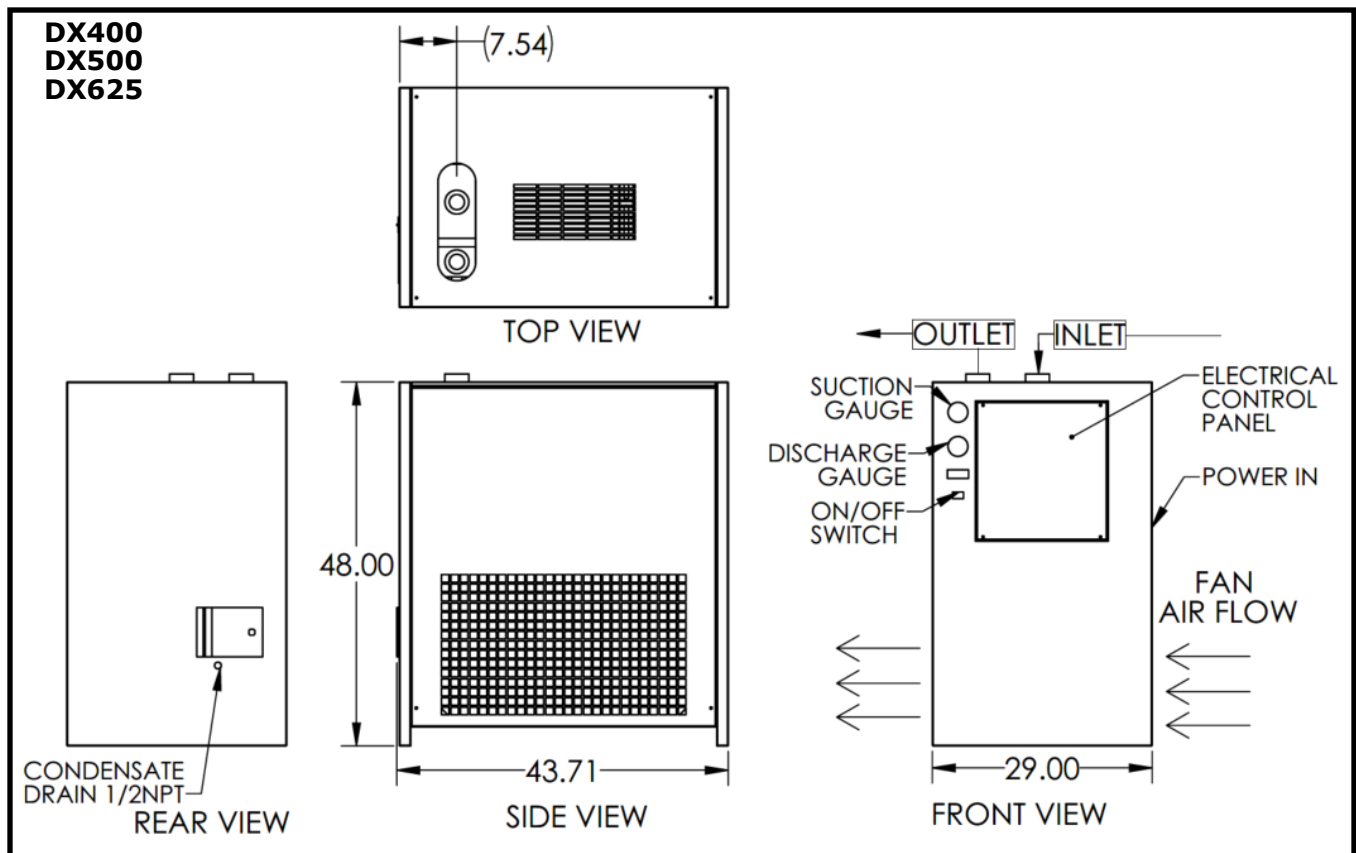

**DX800  
DX1000  
DX1200**

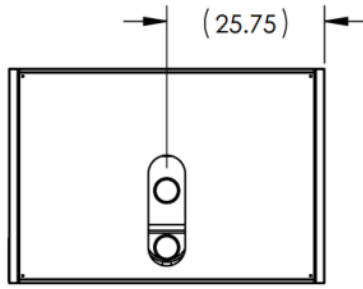

TOP VIEW

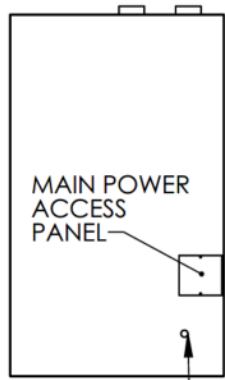

REAR VIEW

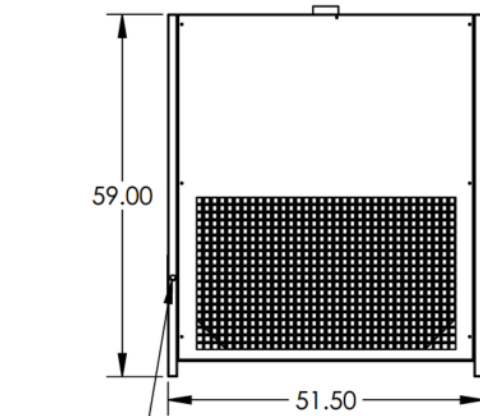

SIDE VIEW

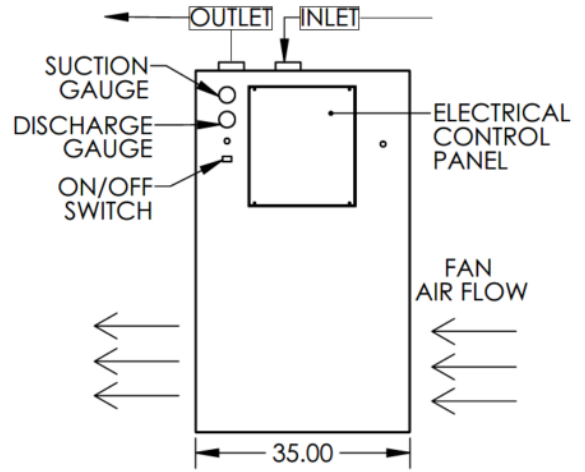

FRONT VIEW

**DX1600  
DX2000**

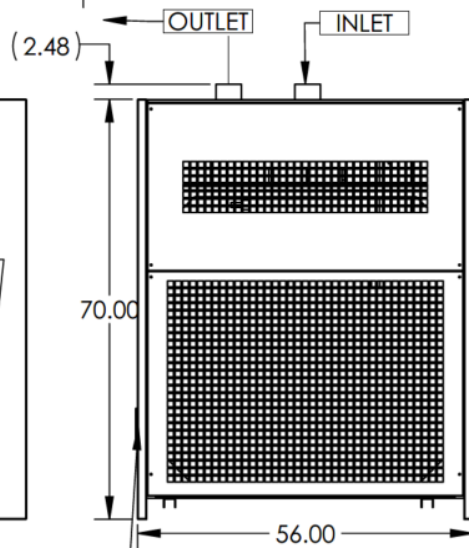
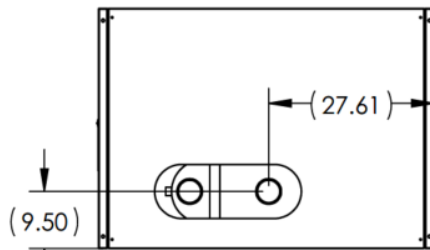

SIDE VIEW

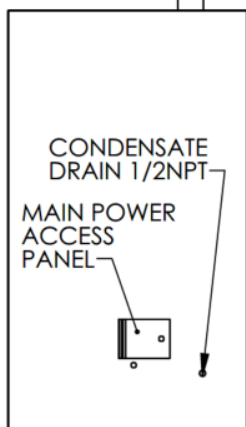

REAR VIEW

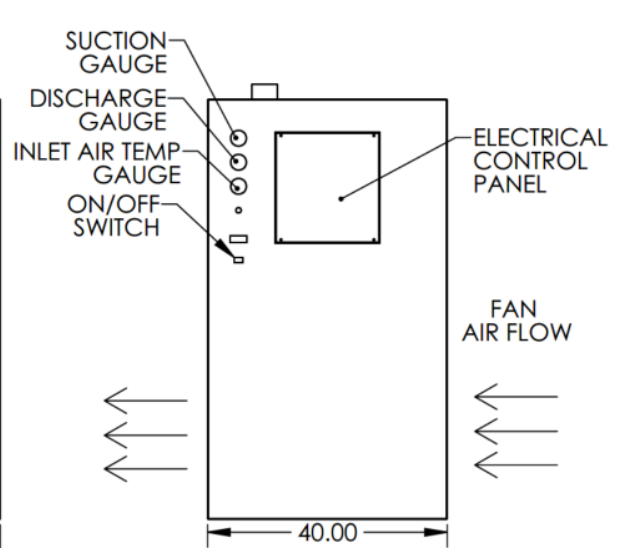

FRONT VIEW

# ELECTRICAL SCHEMATICS

