

ITEM NO	QTY	DESCRIPTION
1	2	DESICCANT VESSEL
2	1	INLET SHUTTLE VALVE
3	1	OUTLET SHUTTLE VALVE
4	2	PURGE EXHAUST VALVE
5	2	EXHAUST MUFFLER
6	2	PRESSURE GAUGE
7	2	PRESSURE RELIEF VALVE
8	2	EMS SENSOR PROBE
9	1	ELECTRICAL ENCLOSURE
10	1	PRE-FILTER
11	1	AFTER FILTER
12	1	ZERO-LOSS DRAIN

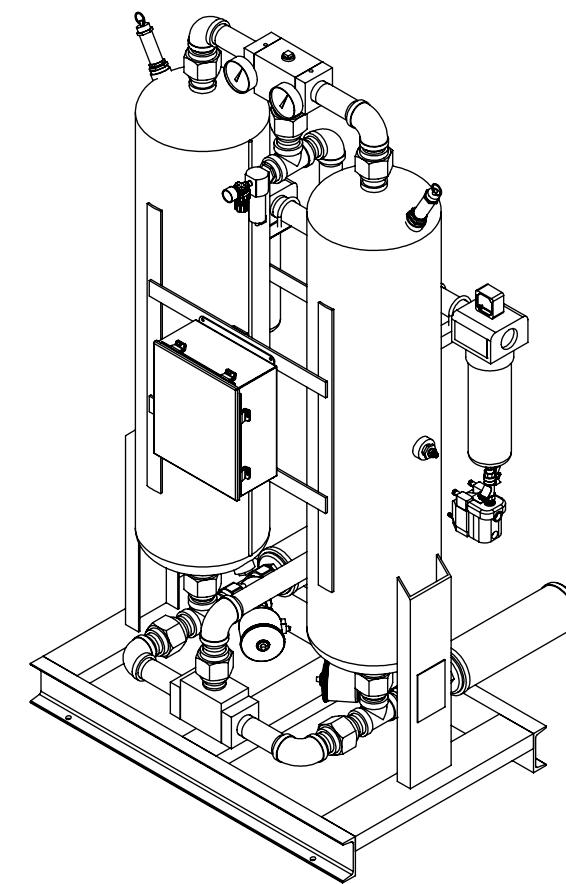

UNLESS OTHERWISE SPECIFIED:

DIMENSIONS ARE IN INCHES  
 TOLERANCES:  
 FRACTIONAL ± 0.125  
 ANGULAR: ± 0.5°  
 TWO PLACE DECIMAL ± .03  
 THREE PLACE DECIMAL ± .003

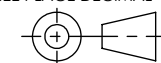

THIRD ANGLE PROJECTION

MATERIAL

FINISH

DO NOT SCALE DRAWING

	NAME	DATE
DRAWN	O.P.	04/03/13
CHECKED	M.S.	04/03/13
ENG APPR.		
MFG APPR.		
Q.A.		
COMMENTS:		

**Aircel** COMPRESSED AIR AND GAS PRODUCTS  
 323 CRISP CIRCLE  
 MARYVILLE TENNESSEE 37801  
 PHONE: 865-681-7066  
 FAX: 865-681-7069

TITLE: DRYER, DESICC, AHL-450, PACK B (REV FILT), 200 PSIG, 100F, T-14

SIZE	DWG. NO.	REV
<b>B</b>	AG9933240-B	<b>5</b>
SCALE: 1:50	WEIGHT:	SHEET 1 OF 1

**PROPRIETARY AND CONFIDENTIAL**  
 THE INFORMATION CONTAINED IN THIS DRAWING IS THE SOLE PROPERTY OF AIRCEL LLC. ANY REPRODUCTION IN PART OR AS A WHOLE WITHOUT THE WRITTEN PERMISSION OF AIRCEL LLC IS PROHIBITED.