

ITEM NO.	QTY.	STOCK #	Description
1	1	AG3998881	HEAT EXCHANGER
2	1	AG3480088	GAUGE, SUCTION, PRESSURE
3	1	AG3939988	CONDENSATE DRAIN
4	1	AG3939980	THERMAL EXPANSION VALVE
5	1	AG3480217	GAUGE, DISCHARGE PRESSURE
6	1	AG3480087	GAUGE, AIR INLET PRESSURE
7	1	AG3112001	TEMP GAUGE
8	1	AG3486147	MOISTURE SEPARATOR
9	1	AG3109201	LIQUID LINE FILTER
10	1	AG3942303	VALVE, BALL-Y-STRAINER COMBO
11	1	AG3941902	FAN BLADES
12	1	AG3941963	TRANSFORMER-CONTROL
13	1	AG3392001	FAN MOTOR
14	1	AG3481603	TANK-LIQUID RECEIVER
15	1	AG3482571	TANK-ACCUMULATOR
16	1	AG3480520	CONTACTOR KIT
17	1	AG3480283	HEATER-CRANKCASE
18	1	AG3942046	DISCHARGE LINE THERMISTOR
19	1	AG3954650	PERFORMANCE ALERT
20	1	AG3942050	COMPRESSOR, 4 HP
21	1	AG3942047	RELAY
22	1	AG3941958	PROTECTOR
23	1	AG3942039	HP SAFETY SWITCH
24	1	AG3942052	SOLENOID VALVE
25	1	AG3942049	SOLENOID COIL
26	1	AG3934651	SOLENOID VALVE COIL KIT
27	1	AG3236801	SUCTION VALVE

NOTE:
FOR ELECTRICAL SPARE/SERVICE PARTS LIST
SEE ELECTRICAL DRAWING

UNLESS OTHERWISE SPECIFIED:
 DIMENSIONS ARE IN INCHES
 TOLERANCES:
 FRACTIONAL ± 0.125
 ANGULAR: ± 0.5°
 TWO PLACE DECIMAL ± .03
 THREE PLACE DECIMAL ± .003

THIRD ANGLE PROJECTION
 MATERIAL
 FINISH
 DO NOT SCALE DRAWING

	NAME	DATE
DRAWN	O.P.	11/14/16
CHECKED	J.J.	11/14/16
ENG APPR.		
MFG APPR.		
Q.A.		
COMMENTS:		

Aircel COMPRESSED AIR AND GAS PRODUCTS
 323 CRISP CIRCLE
 MARYVILLE TENNESSEE 37801
 PHONE: 865-681-7066
 FAX: 865-681-7069

TITLE: AES-800, REFRIGERATED AIR DRYER, 800 SCFM, 100 PSIG, 100F, SPARE PARTS

SIZE	DWG. NO.	REV
B	AG9999705	0

SCALE: 1:20 WEIGHT: SHEET 1 OF 1

PROPRIETARY AND CONFIDENTIAL
 THE INFORMATION CONTAINED IN THIS DRAWING IS THE SOLE PROPERTY OF AIRCEL LLC. ANY REPRODUCTION IN PART OR AS A WHOLE WITHOUT THE WRITTEN PERMISSION OF AIRCEL LLC IS PROHIBITED.

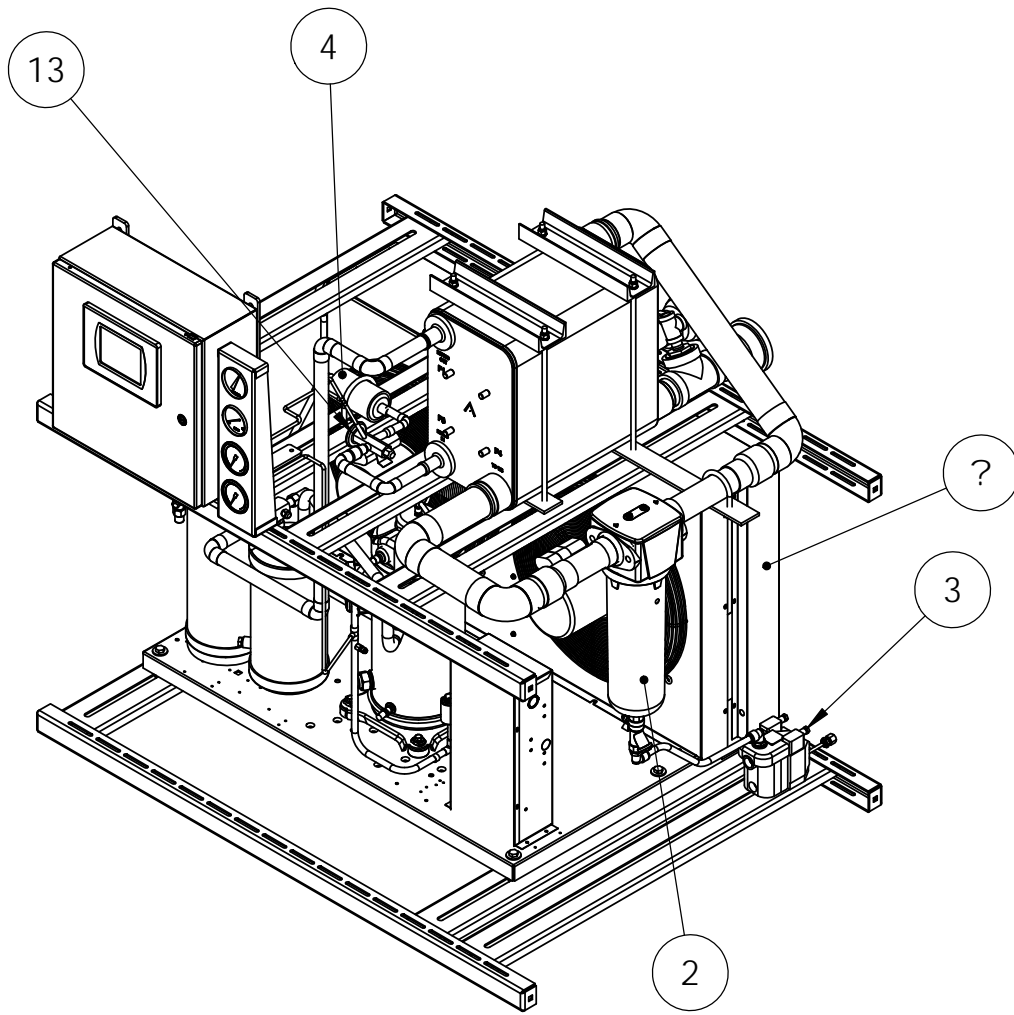
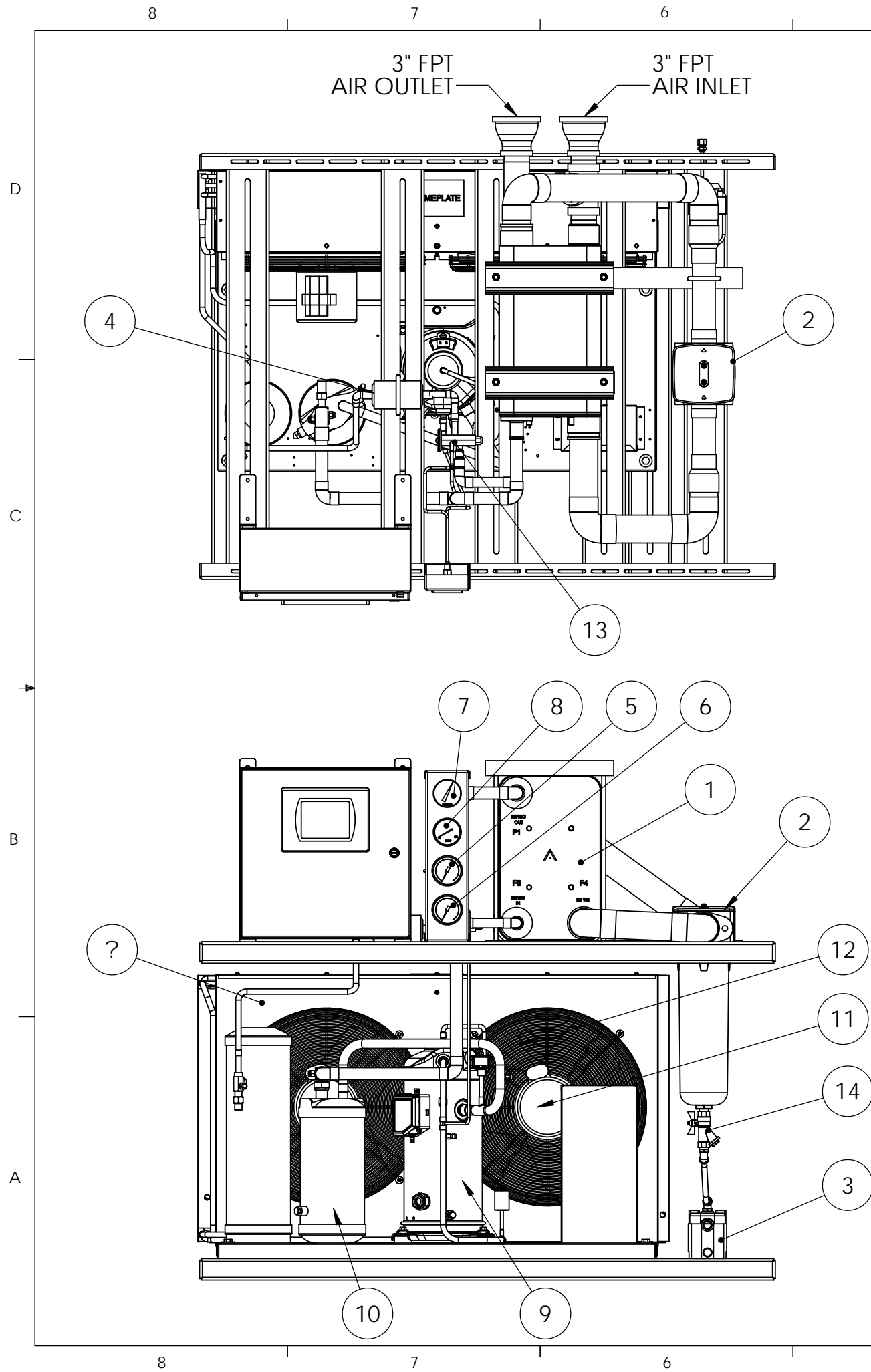

ITEM	QTY.	STOCK #	Description
1	1	AG3998881	HEAT EXCHANGER
2	1	AG3486147	MOISTURE SEPARATOR
3	1	AG3949988	CONDENSATE DRAIN
4	1	AG3109201	LIQUID LINE FILTER
5	1	AG3480088	GAUGE, SUCTION, PRESSURE
6	1	AG3480217	GAUGE, DISCHARGE PRESSURE
7	1	AG3480087	GAUGE, AIR INLET PRESSURE
8	1	AG3112001	TEMP GAUGE
9	1	AG3942050	COMPRESSOR, 4 HP
10	1	AG3482571	TANK-ACCUMULATOR
11	1	AG3392001	FAN MOTOR
12	1	AG3941902	FAN BLADES
13	1	AG3939980	THERMAL EXPANSION VALVE
14	1	AG3942303	VALVE, BALL-Y-STRAINER COMBO
15	1	AG3481603	TANK-LIQUID RECEIVER
16	1	AG3941963	TRANSFORMER-CONTROL
17	1	AG3480520	CONTACTOR KIT
18	1	AG3480283	HEATER-CRANKCASE
19	1	AG3942039	HP SAFETY SWITCH
20	1	AG3954650	PERFORMANCE ALERT
21	1	AG3941958	PROTECTOR
22	1	AG3942047	RELAY
23	1	AG3942049	SOLENOID COIL
24	1	AG3942052	SOLENOID VALVE
25	1	AG3934651	SOLENOID VALVE COIL KIT
26	1	AG3942046	DISCHARGE LINE THERMISTOR
27	1	AG3236801	SUCTION VALVE

UNLESS OTHERWISE SPECIFIED:
 DIMENSIONS ARE IN INCHES
 TOLERANCES:
 FRACTIONAL ± 0.125
 ANGULAR: ±0.5°
 TWO PLACE DECIMAL ± .03
 THREE PLACE DECIMAL ± .003



THIRD ANGLE PROJECTION
 MATERIAL
 FINISH
 DO NOT SCALE DRAWING

	NAME	DATE
DRAWN	O.P.	11/14/16
CHECKED	J.J.	11/14/16
ENG APPR.		
MFG APPR.		
Q.A.		
COMMENTS:		

Aircel COMPRESSED AIR AND GAS PRODUCTS
 323 CRISP CIRCLE
 MARYVILLE TENNESSEE 37801
 PHONE: 865-681-7066
 FAX: 865-681-7069

TITLE: AES-800, REFRIGERATED AIR DRYER, 800 SCFM, 100 PSIG, 100F, SPARE PARTS

SIZE	DWG. NO.	REV
B	AG8803000	0

SCALE: 1:20 WEIGHT: SHEET 1 OF 1

PROPRIETARY AND CONFIDENTIAL
 THE INFORMATION CONTAINED IN THIS DRAWING IS THE SOLE PROPERTY OF AIRCEL LLC. ANY REPRODUCTION IN PART OR AS A WHOLE WITHOUT THE WRITTEN PERMISSION OF AIRCEL LLC IS PROHIBITED.