



POWERFLEX™ AH



AIR COMPRESSOR



HYDRAULIC PUMP

For When You Only Need An Air Compressor and Hydraulic Output Power!

Like its counterpart, the PowerFlex™ AH is equipped with a 40 CFM at 150 PSI rotary screw air compressor, but instead of a generator it is equipped with a hydraulic pump, providing 13 GPM and up to 3000 PSI with an integrated hydraulic reservoir. Tier 4 Final compliant, the PowerFlex™ AH is small enough to fit in a variety of load spaces.

SPECIFICATIONS	
CFM Rating	40 CFM @ High Speed / 30 CFM @ Idle Speed
Air Pressure	150 PSI
Hydraulic Flow*	Up to 13 GPM
Hydraulic Pressure*	Up to 3000 PSI
Engine Type	25 HP Kubota® Tier 4 Final
Drive System	Belt Driven
Fuel Type	Diesel
Fuel Capacity	Tied to Chassis or Remote Tank
Compressor Type	Rotary Screw

Powerflex™ AH Unit Dimensions with fittings (In.): 47.6 L x 21.0 W x 33.4 H
Dry Weight (Lbs.): 802



POWERFLEX[™]

AH

SPECIAL FEATURES

- Small Compact Design
- Can Be Side-Mounted or Bed-Mounted
- Can Power a Separate Cab Climate Control System

AIR COMPRESSOR

- 40 CFM Rotary Screw Encapsulated Air End
- Belt-Driven
- Lifetime Warranty on Air End
- Integrated Inlet

HYDRAULICS

- Rated @ 10.5 RPM @ 2000 PSI and 8.5 RPM @ 3000 PSI
- Variable Displacement Pump

CANOPY

- Small Compact Design
- Powder-Coated, Galvanneal Sheet Metal Enclosure

SAFETY EQUIPMENT

- Low Engine Oil Shut Down
- Alternator Failure Indicator
- Service Access Door Shut Down
- Engine Over Temp Shut Down
- Air Pressure Safety Relief Valve And Automatic Blow-Down On Shut Down
- High-Temperature & High-Pressure Compressor Shut Down
- Oil Fill Plug Safety Relief
- Hydraulic Oil Pressure-Relief Valve

REMOTE CONTROL PANEL

- Remote Control Panel
- Engine Start/Stop
- Engine Fault Lights
- Hour Meter
- Compressor/Hydraulic On/Off Switch
- Speed Control Switch
- Compressor Fault Light

MAINTENANCE/SERVICEABILITY

- Hinged Top and Removable Front Panel for Easy Access
- Spin On Air-Oil Separator Element for Easy Maintenance

OPTIONS/ACCESSORIES

- Air Reservoirs
- After Coolers
- Air Hoses
- Filter/Lubricator/Regulator (FLR)
- Hose Reels
- Moisture Separators
- Tool Oilers
- Air Tools
- Maintenance Kits
- Receptacles

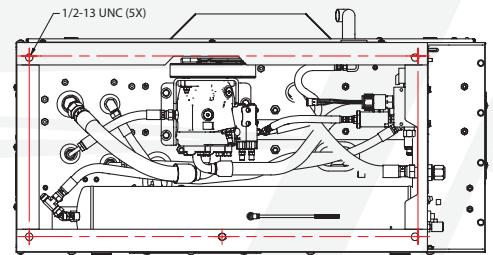
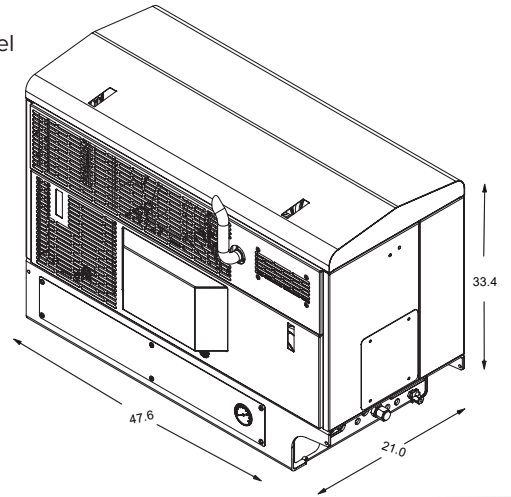

MOUNTING HOLES

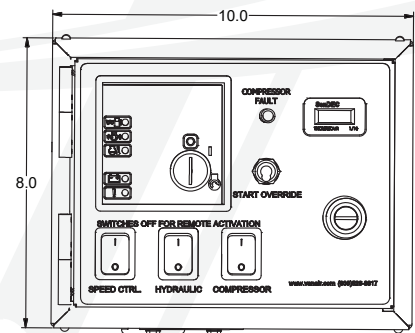

REMOTE CONTROL PANEL

Vanair reserves the right to make changes in engineering, design, and specifications; add improvements; or discontinue manufacturing at any time without notice or obligation. Vanair, the Vanair logo and MOBILE POWER SOLUTIONS are registered trademarks or trademarks of Vanair Manufacturing, Inc., Michigan City, IN, USA. © 2021 All Rights Reserved.



800.526.8817 | vanair.com

10896 West 300 North | Michigan City, Indiana 46360 USA



POWERFLEXAH_07262021_NML