

All materials supplied are in compliance with the requirements of the List of Prohibited Substances

CONFIDENTIAL: This document is property of Atlas Copco AB and shall not without our permission be altered, copied, used for manufacturing or communicated to any other person or company.

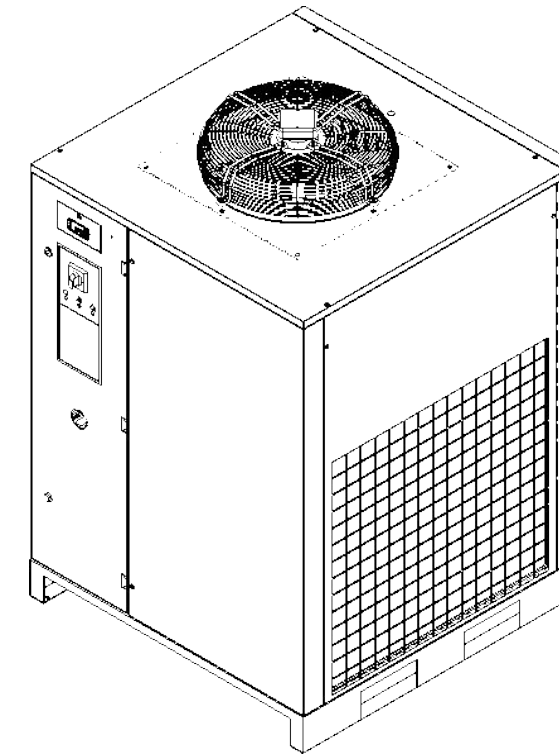
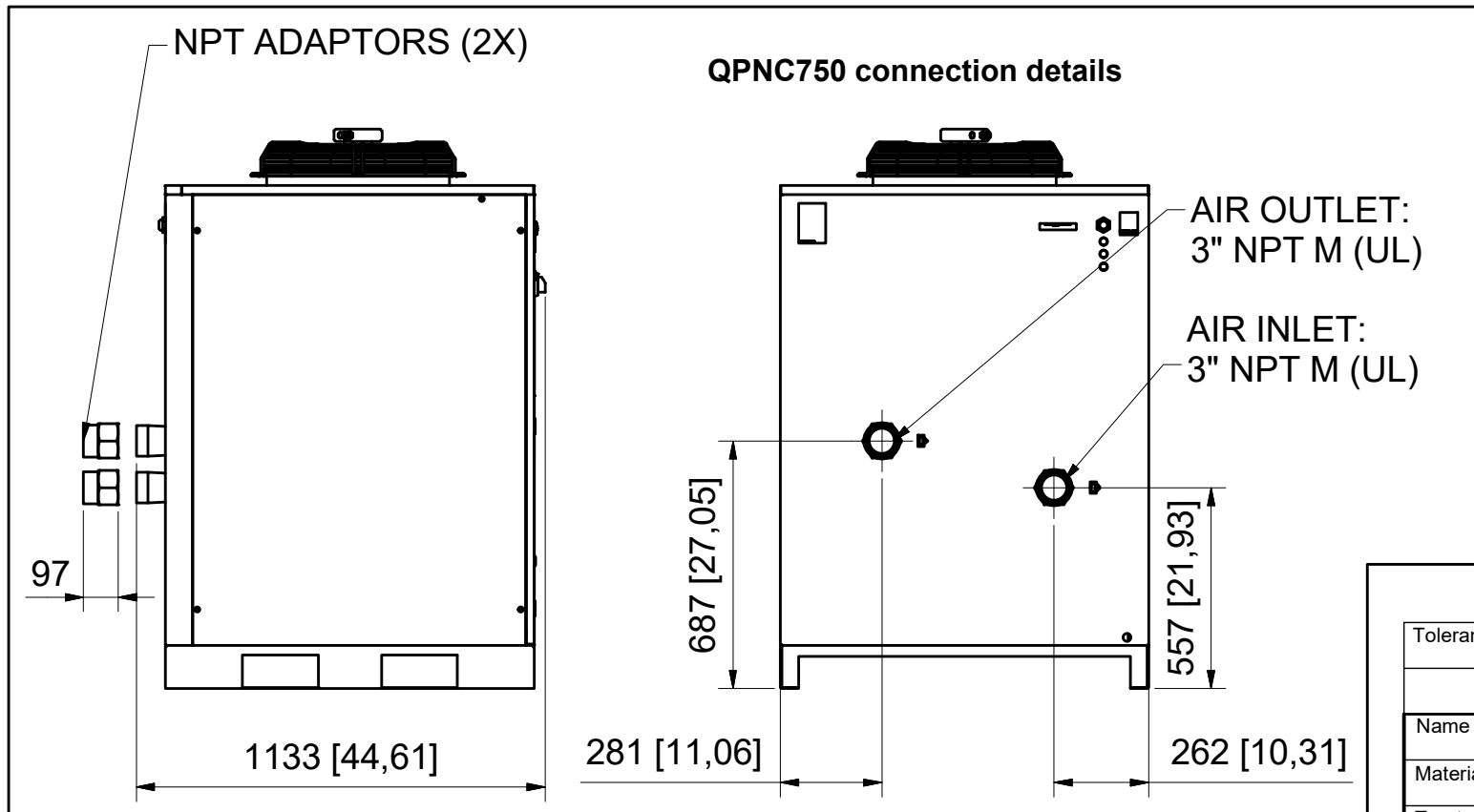
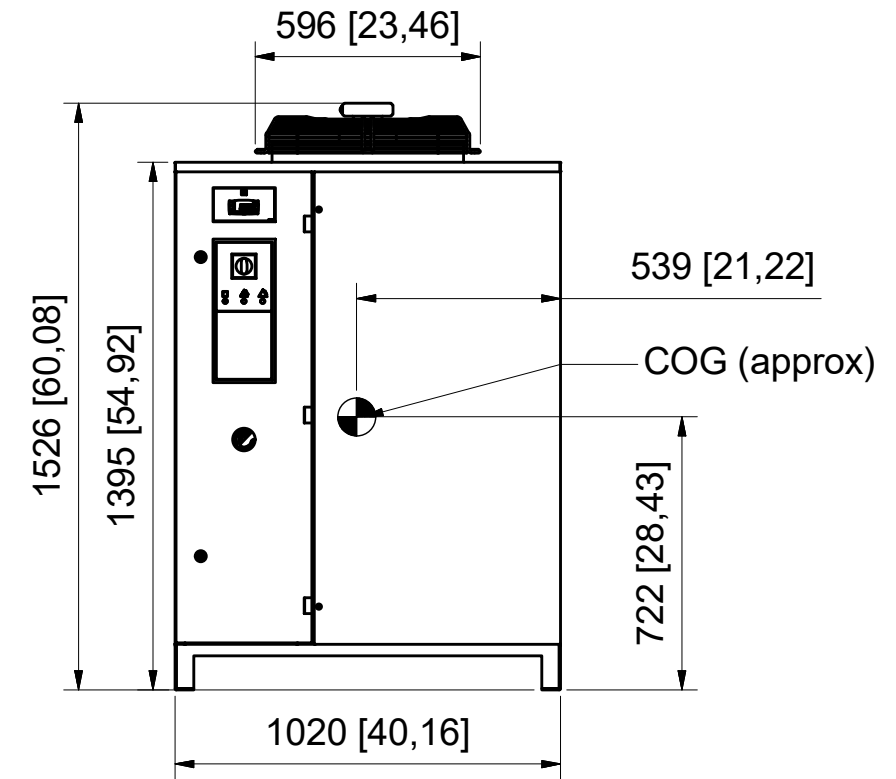
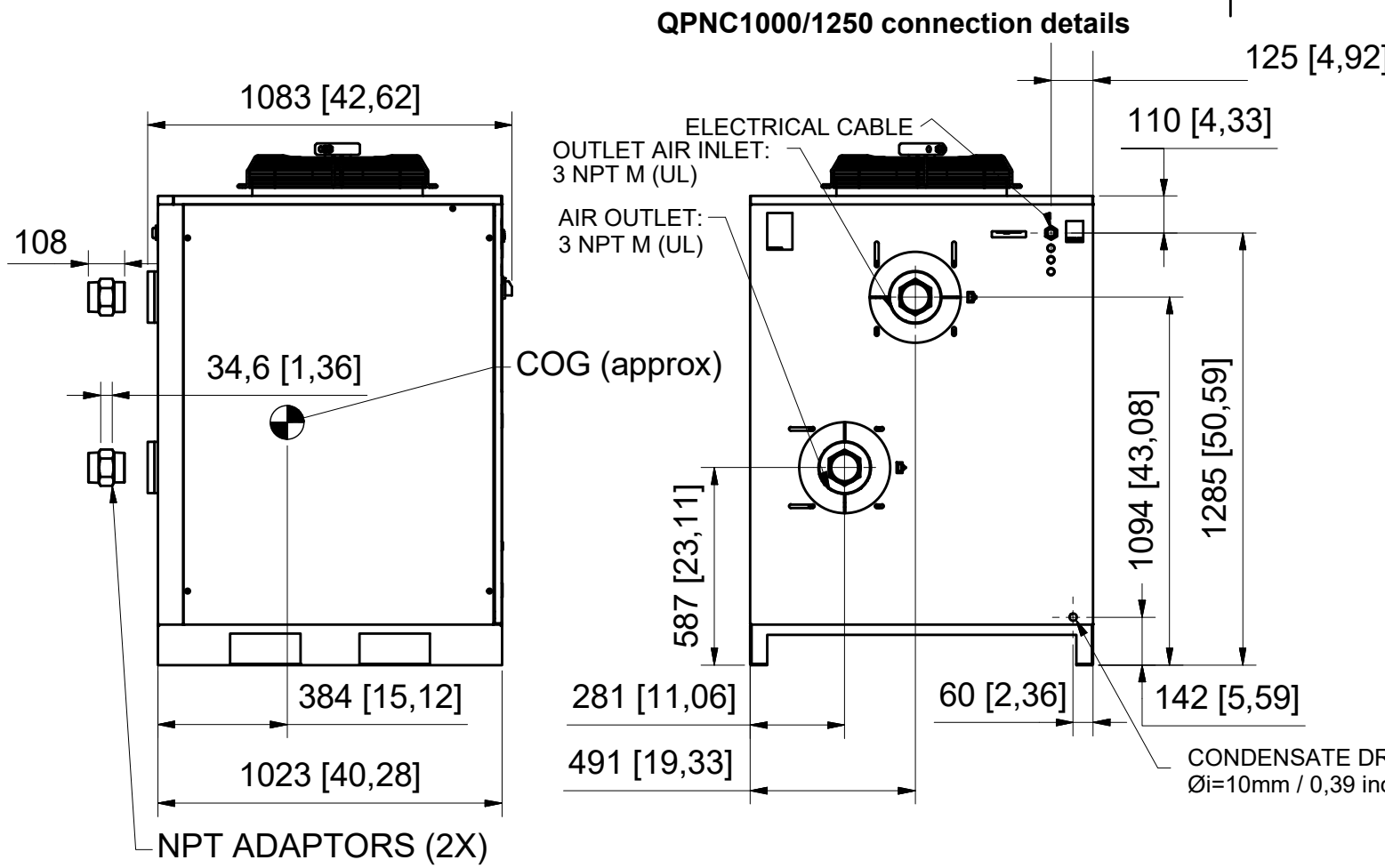

Dryer	Variant	Weight
750	400V/460V	325 kg / 716,5 lb
1000	400V/460V	335 kg / 738,58 lb
1250	400V/460V	350 kg / 771,6 lb

Tolerances, if not indicated, according to:									
Name DIM. DRAWING QPNC750-1250								Confidentiality Class acc. to 1102 K	
Material not applicable								Confidential	
Treatment not applicable								INV	
Scale 1 : 20		Family		Compare		Drawing Owner		Transferred from	
Drawn by asartori		Blank nr.		Replaces		CAI			
Drawing format A3		Blank wt		Kg		Fini wt. 0,000 kg		Designation	
Des checked.		Prod checked.		Approved.		Date 15/05/2017		Sheet 1 / 1	
Approved		9828083517							

Unit measurement in mm
[x] = inches

03		20-04-2018	asavio ,	9828083319	03.00
Ed	Position	Date	Intr./Appd.	Parent 3D model	Ed . Version 3D

