

## HTDN Series

High Inlet Temperature Refrigerated Compressed Air Dryers

Models: HTDN 20, HTDN 25, HTDN 35, HTDN 50, HTDN 75, HTDN 125

FORM NO.: 7477625 REVISION: 10/2019

READ AND UNDERSTAND THIS MANUAL PRIOR TO OPERATING OR SERVICING THIS PRODUCT.



## Contents

GENERAL SAFETY INFORMATION .....	1
RECEIVING, MOVING, AND UNPACKING .....	1
INSTALLATION .....	2
INSTRUMENTATION .....	3
START-UP/OPERATION.....	4
SHUTDOWN.....	4
MAINTENANCE.....	4
FIELD SERVICE GUIDE.....	6
ENGINEERING DATA .....	7
GENERAL ARRANGEMENT DRAWINGS	
Model HTDN 20.....	8
Model HTDN 25.....	9
Model HTDN 35.....	10
Model HTDN 50.....	11
Model HTDN 75.....	12
Model HTDN 125.....	13
ELECTRICAL SCHEMATICS	
Models HTDN 20 and HTDN 25.....	14
Models HTDN 35, HTDN 50, and HTDN 75.....	15
Model HTDN 125.....	16
AIR AND REFRIGERANT FLOW SCHEMATIC.....	17
REPLACEMENT PARTS.....	18
MAINTENANCE KITS .....	19
WARRANTY .....	21

## GENERAL SAFETY INFORMATION

### 1. PRESSURIZED DEVICES:

This equipment is a pressure containing device.

- Do not exceed maximum operating pressure as shown on equipment serial number tag.
- Make sure equipment is depressurized before working on or disassembling it for service.

### 2. ELECTRICAL:

This equipment requires electricity to operate.

- Install equipment in compliance with all applicable electrical codes.
- Standard equipment is supplied with electrical enclosures not intended for installation in hazardous environments.
- Disconnect power supply to equipment when performing any electrical service work.

### 3. BREATHING AIR:

- Air treated by this equipment may not be suitable for breathing without further purification.

Refer to applicable standards and specifications for the requirements for breathing quality air.

## RECEIVING, MOVING, AND UNPACKING

### 1. RECEIVING

This shipment has been thoroughly checked, packed and inspected before leaving our plant. It was received in good condition by the carrier and was so acknowledged.

Check for Visible Loss or Damage. If this shipment shows evidence of loss or damage at time of delivery to you, insist that a notation of this loss or damage be made on the delivery receipt by the carrier's agent.

### 2. UNPACKING

Check for concealed loss or damage. When a shipment has been delivered to you in apparent good order, but concealed damage is found upon unpacking, notify the carrier immediately and insist on his agent inspecting the shipment. Concealed damage claims are not our responsibility as our terms are F.O.B. point of shipment.

### 3. MOVING

In moving or transporting dryer, do not tip dryer onto its side.

### 4. STORAGE

**IMPORTANT:** Do not store dryer in temperatures above 130°F (54.4°C).

## INSTALLATION

### Ambient Air Temperature

Locate the dryer indoors where the ambient air temperature will be between 40°F and 110°F. Intermittent operation at ambient temperatures up to 110°F will not damage the dryer but may result in a higher dew point or dryer shutdown due to high refrigerant discharge pressure (see Field Service Guide).

Do not operate air-cooled dryers at ambient air temperatures below 40°F. Such operation may result in low suction pressure, causing freeze-up.

### Location and Clearance

Mount the dryer on a level base. If the base vibrates, bolt the unit down using vibration dampeners. Install dryer in a clean, well-ventilated area to reduce fouling of the condenser coils with dirt and dust. Allow at least 24 inches clearance on the sides and the front of the dryer for cooling airflow and for service access.

### System Arrangement

Liquid water in the inlet air will adversely affect the performance of the dryer. Install the dryer downstream of an aftercooler or separator so that the temperature of the dryer inlet air does not exceed 180°F and the inlet air does not contain any liquid water.

If the compressed airflow is relatively constant and does not exceed the dryer flow rating, it is recommended that the dryer be located downstream of the receiver tank. If the nature of the application is such that the air demand regularly exceeds the dryer flow rating, it is recommended that the dryer be located upstream of the receiver.

For safety and convenience, install inlet and outlet shutoff valves and depressurization valves. These valves allow the dryer to be isolated and depressurized for servicing. Bypass piping may be installed around the dryer for uninterrupted airflow when the dryer is serviced. If the compressed air operation cannot tolerate undried air for short periods, install a second dryer in the bypass line.

Compressed air systems commonly require filters to remove compressor oils, particulates, condensed liquids and other contaminants. When an oil-removal filter is used, it should be installed downstream of the refrigerated dryer. At this location, the life of the replaceable filter element is prolonged since some of the entrained oil is removed by the dryer and drained through the separator.

**NOTE:** For filter package option units, install filters downstream of the dryer where the air temperature is 150°F or less.

### Piping and Connections

Piping must be furnished by the user unless otherwise specified. Connections and fittings must be rated for the maximum operating pressure given on the dryer data plate and must be in accordance with applicable codes. Support all piping; do not allow the weight of any piping to stress the dryer or filter connections. A 3 valve dryer isolation and bypass assembly is recommended. Piping should be at least the size of the inlet and outlet connections to minimize pressure drop in the air system. See General Arrangement drawings for dryer inlet and outlet connections.

### Removing Condensate

Condensate must be drained from the dryer to prevent re-entrainment. The dryers are equipped with automatic drain valves and internal drain hoses up to the drain connections on the dryer cabinets. The user must install a separate discharge line at the drain connection to carry off condensate to an environmentally approved condensate collection/disposal system. Piping or copper tubing 1/2 inch or larger is recommended for condensate discharge lines. Install the drain lines so that condensate can be seen as it drains.

### Electrical Connections

The dryers are constructed according to NEMA Type 1 electrical standards. Field wiring must comply with local and national fire, safety and electrical codes. Installation must be in accordance with the National Electrical Code. Confirm that your line voltage is the same as the voltage listed on the dryer data plate. Refer to electrical schematics.

**⚠ CAUTION** Operation of dryers with improper line voltage constitutes abuse and could affect the dryer warranty.

## INSTRUMENTATION

### ON/OFF Switch

The dryer is equipped with an ON/OFF switch on the front panel. A light signals when the dryer is on.

### Dew Point Indicator

All dryers are equipped with a dew point indicator which indicates dryer conditions as follows:

It is normal for the dew point indicator to be in the red zone when the dryer is first turned on and then move to the green zone when the dryer reaches its normal operating temperature. If this indicator is in the red zone during normal operation, turn the dryer off to avoid compressor damage. Refer to the Field Service Guide for additional information, or call your local distributor.

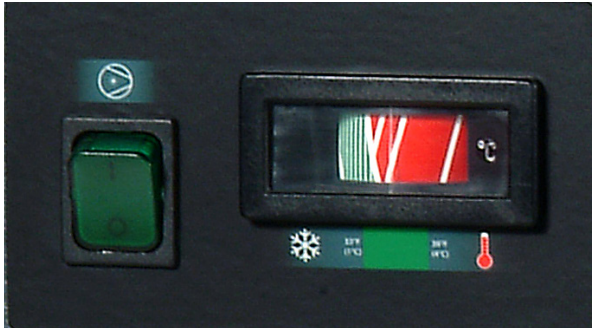

ON/Off Switch and Dew Point Indicator

### Automatic Drain Valve

All models are equipped with an electronic drain valve that automatically discharges condensate from the dryer. Drain valve operation is controlled by a drain valve timer. The timer is mounted directly on the drain valve. The drain opening can be set from 0.5 seconds to 10 seconds. The drain cycle can be set from 0.5 minutes to 45 minutes.

### Electronic Drain Valve Adjustment

To minimize air losses, the drain valve control time should be adjusted to open the drain port just long enough to discharge accumulated condensate. Set the drain valve operating time so that only air discharges at the end of the open period. Recommended initial settings are a 1 to 2 second drain opening and 30 seconds drain closed time. If liquid still discharges as the port is closing, set the timer for a shorter cycle or a longer opening.

**NOTE:** The amount of condensate will vary as ambient conditions and inlet flow rates change

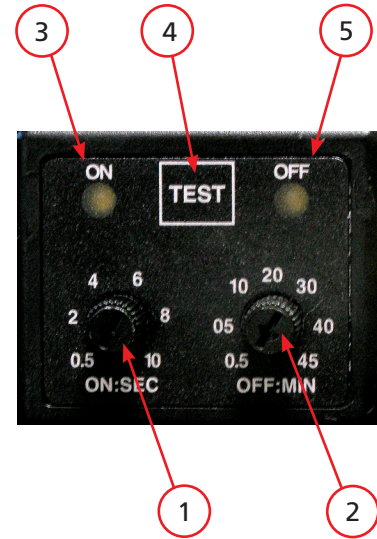

Drain Timer

1. Adjustment knob for the drain valve open time. The values on the dial correspond to the time in seconds that the valve is open in each drain cycle.
2. Adjustment knob for the drain valve closed time. The values on the dial correspond to the time in minutes that the valve is closed in each drain cycle.
3. LED to indicate when the drain valve is open.
4. Drain test button. When the button is pressed, the drain valve opens for the time corresponding to the setting on item 1.
5. LED to indicate when the drain valve is closed.

## START-UP/OPERATION

Follow the procedure below to start your dryer. Failure to follow the prescribed start-up procedure will invalidate the warranty. If problems arise during start-up, call your distributor.

**⚠WARNING** Refer to Serial Number Tag for dryer operating capacity. Do not exceed recommended capacity.

Drain connections must be made before the dryer can be operated. The dryers are fully automatic and require no auxiliary controls.

1. Turn the dryer ON/OFF switch to OFF.
2. Check that the main electrical supply voltage matches the voltage specified on the dryer data plate.
3. Check proper connection and support of compressed air lines to the dryer; check bypass valve system, if installed.
4. SLOWLY pressurize the dryer. The outlet valves of the dryer should be closed to prevent flow through the dryer.
5. Turn on the main electrical power to the dryer.
6. Ensure adequate ventilation.

### To start dryer:

1. Turn the power switch to ON. The refrigerant compressor will turn on.
2. Allow the dryer to run 15 minutes. Confirm that the temperature indicators are in the green zone.
3. SLOWLY open the dryer outlet valves permitting flow through the dryer.
4. Confirm that condensate is discharging from the drain valve by pressing the "TEST" button.
5. Check drain valve timing. See Electronic Drain Valve Adjustment section for adjustment procedure.
6. Confirm that the inlet air temperature, pressure and airflow to the dryer meet the specified requirements (see Engineering Data section).
7. Confirm that the condensate lines from the drain valve discharge into the customer condensate drainage system or collection tank.

The dryer is designed to run continuously. Let the dryer run even when the demand for compressed air is interrupted; the dryer will not freeze up.

## SHUTDOWN

When the dryer must be shutdown for maintenance or other reasons, use the following procedure.

If electrical repairs must be made:

1. Turn off the power switch.
2. Disconnect the main power supply.
3. Lock out and tag the power supply in accordance with OSHA requirements.

If mechanical repairs are to be made or service is performed, vent the internal pressure of the dryer to atmospheric pressure. Restart the dryer according to the start-up instructions.

**⚠WARNING** Disconnect power supply and depressurize dryer before servicing. Dismantling or working on any component of the compressed air system under pressure may cause equipment failure and serious personal injury.

## MAINTENANCE

The dryers require little maintenance for satisfactory operation. Good dryer performance can be expected if the following routine maintenance steps are taken.

**⚠WARNING** Dismantling or working on any component of the compressed air system under pressure may cause equipment failure and serious personal injury. Before dismantling any part of the dryer or compressed air system, completely vent the internal pressure to the atmosphere.

### General

For continued good performance of your refrigerated dryer, all refrigeration system maintenance should be performed by a competent refrigeration mechanic.

**NOTE:** Before corrective maintenance is done during the warranty period, call your local distributor and proceed according to instructions. Refer to the warranty for limits of your coverage.

### Daily Maintenance

Check the operation of the automatic drain valve at least once daily. See the Field Service Guide for remedies to drain valve malfunctions. See the Electronic Drain Valve Adjustment section for drain valve adjustment.

### Monthly Maintenance

1. Clean condenser from dust and dirt with dry compressed air at suitable distance.
2. Do not adjust the expansion valve.
3. Inlet strainer - clean inlet strainer monthly or more often if rapid clogging occurs..
  - a. Shut-off compressed air supply to the strainer and depressurize. Turn off power to the dryer.
  - b. Remove screen and clean or replace.
  - c. Reinstall.

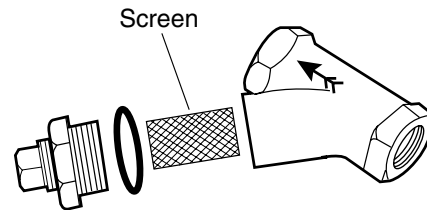

## Electronic Drain Valve Disassembly and Servicing

**⚠ CAUTION** Do not disassemble drain valve timer or attempt to repair electrical parts. Replace drain assembly if defective.

The drain valve discharges condensate through a full-port drain opening. The valve body may need to be cleaned under conditions of gross particulate contamination.

To disassemble the drain valve body for cleaning and other maintenance:

1. Turn power switch off.
2. Disconnect main power supply to dryer.
3. Depressurize unit.
4. Lock out and tag power supply in accordance with OSHA requirements.

**⚠ WARNING** If power supply is not connected and unit is not depressurized before disassembly, serious personal injury and valve damage may result.

5. Removes hoses that connect the drain valve to the drain discharge fitting and remove the valve from the drain valve strainer.
6. Remove screw and washer from front of the drain valve.
7. Remove the power supply connector and gasket (with the timer assembly if attached) from the solenoid coil housing. Do not damage or lose the gasket.
8. Remove coil fixing nut from top of solenoid coil housing.
9. Lift solenoid coil housing off solenoid core in valve body.
10. Unscrew solenoid core from valve body.

Once the drain valve is disassembled, the following maintenance can be performed.

1. Inspect internal parts of valve body; clean or replace as required.

**NOTE:** Replace drain assembly if component damage is observed.

2. Remove debris from valve body.
3. Wipe solenoid core components with a clean cloth or blow out debris with compressed air from an OSHA-approved air nozzle that limits its discharge pressure to 30 psig.
4. Check that the plunger assembly is clean and moves freely in housing.
5. If timer is attached to valve body, check electrical continuity across timer assembly.

To reassemble the drain valve, reverse the sequence of the preceding steps. After the drain valve is reassembled, connect the main power supply to the dryer.

When the dryer is returned to service, check the drain valve for air or condensate leaks; tighten connections as required to correct leaks. Check the drain cycle; adjust the timer according to the procedure in the drain valve adjustment section.

## Returns to Manufacturer

If the dryer or a component of the dryer must be returned to the manufacturer, first call your local distributor for a return authorization number and shipping address. Your distributor will inform you whether the dryer or only a component must be returned. Mark the package with the return authorization number and ship freight prepaid as directed by your local distributor.

## FIELD SERVICE GUIDE

Problems most frequently encountered with refrigerated dryers are water downstream of the dryer and excessive pressure drop. Most causes can be identified and remedied by following this guide.

**⚠ WARNING** Closed refrigeration systems are potentially dangerous. Work on the refrigeration system must be done only by a competent licensed refrigeration mechanic. Do not release fluorocarbon refrigerants to the atmosphere. Do not discharge liquid refrigerants into floor drains. Refrigerant vapors may accumulate in low places. Inhalation of high concentrations may be fatal. All refrigerants must be recovered per EPA requirements.

Do not smoke when a refrigeration leak is suspected. Burning materials may decompose refrigerants, forming a toxic gas or acids that may cause serious injury and property damage.

Before dismantling any part of the dryer or compressed air system, completely vent the internal pressure to the atmosphere.

PROBLEM	SYMPTOM	POSSIBLE CAUSE	REMEDY
Water Downstream of Dryer	Refrigerant compressor not running.	Loss of power to dryer	Check power supply, fuses and/or breakers. Check for loose connections.
		Dryer turned off.	Check On/Off switch position.
		Dryer overloaded.	Confirm that inlet flow, inlet temperature and inlet pressure are within acceptable range of dryer.
		Condenser clogged with debris.	Check/clean ambient air filter and condenser.
		Fan motor inoperative	Check fan motor operation. Replace if necessary.
		Ambient temperature too high.	Verify ambient temperature throughout day.
		High pressure switch activated	Press manual reset button.
		Compressor overheated.	Turn dryer off. Contact local distributor.
		Compressor defective.	Turn dryer off. Contact local distributor.
	No condensate discharging from drain line.	Drain strainer clogged.	Clean drain strainer.
		Drain valve inoperative.	Check/replace drain valve assembly.
		Drain timer inoperative.	Confirm there is power to the timer. Replace drain valve assembly, if necessary.
Drain solenoid inoperative.		Confirm there is power to the coil. Replace drain valve assembly, if necessary.	
Condensate not fully discharging from dryer.	Incorrect drain timer setting.	Adjust drain timer - increase open time and/or decrease closed time.	
Liquid water entering dryer.	Aftercooler drain valve malfunction.	Check, repair aftercooler drain valve.	
Excessive Pressure Drop Across Dryer	Frozen condensate in evaporator.	Do not adjust the expansion valve.	Contact local distributor.
	Inlet air pressure low.	Upstream restriction in air system.	Check all upstream air system components (valves, regulators, etc.)
	Dryer undersized.	Excessive compressed air flow.	Resize dryer.
Dew Point Indicator Out of Green Zone		Dryer overloaded.	Confirm that inlet flow, inlet temperature and inlet pressure are within acceptable range of dryer.
		Condenser clogged with debris.	Check/clean ambient air filter and condenser.
		Loose sensor connection.	Confirm gauge or temperature sensor is tightly connected to dryer tubing.
		Defective temperature sensor.	Replace temperature sensor.



# ENGINEERING DATA

Description	Model					
	20	25	35	50	75	125
<b>Operating Conditions</b>						
Rated Capacity (scfm)*	20	25	35	50	75	125
Minimum/Maximum Working Pressure	42 / 227 psig (3.0 / 16.0 barg)					
Minimum/Maximum Inlet Temperature**	40° / 180°F (4°C / 82°C)					
Minimum/Maximum Ambient Temperature	40° / 110°F (4°C / 43°C)					
Pressure Drop @ rated capacity	1.2 psig	1.8 psig	2.4 psig	2.7 psig	3.0 psig	2.9 psig
<b>Refrigeration System Data</b>						
Compressor Type	Hermetic, Reciprocating			Hermetic, Rotary		
Refrigeration Capacity @ Rated Flow (BTU/hr)*	4982		9724	12420		19300
Outlet Air Temperature** (nominal @ rated conditions)	158°F (70.2°C)	157°F (69.4°C)	156°F (69.2°C)	157°F (69.6°C)	158°F (70.2°C)	160°F (71.1°C)
Refrigerant Type	R-134a			R-407C		
Refrigerant Charge	See Dryer Serial Tag					
Suction Pressure Setting	31 psig (2.1 barg)			60 psig (4.1 barg)		
Compressor Pressure Switch Setting (cut out / cut in)	298 psig / manual reset (20.5 barg / manual reset)			398 psig / manual reset (27.4 barg / manual reset)		
Condenser Fan Switch Setting (cut out / cut in)	199-142 psig (13.7-9.8 barg)			213-198 psig (14.7-13.6 barg)		
Air Flow Across Condenser (cfm)	705			1000		1707
<b>Electrical Data</b>						
Nominal Voltage	115/1/60					230/1/60
Minimum/maximum volts	104 - 127					208 - 253
Input Power @ Rated Flow (watts) *	670	690	990	830	1,130	1,970
Full Load Amps (FLA)	6.95		8.25	8.6	10.7	9.3
Minimum Circuit Ampacity	8.6		10.2	10.6	13.1	11.4
Maximum Overcurrent Protector (amps)	15.1		18.1	18.5	23.0	19.9
Compressor						
Rated Load Amps (RLA)	6.6		7.9		10.0	8.6
Locked Rotor Amps (LRA)	33.8		42		56	50
Condenser fan motor						
Volts/phase/Watts (output)	115/1/16			115/1/200		230/1/100
Full Load Amps (FLA)	0.35			0.70		

\* Rating conditions are 180°F inlet temperature, 125 psig inlet pressure, 160°F inlet pressure dewpoint, 95°F ambient temperature.

\*\* For filter package option units, install filters downstream of the dryer where the air temperature is 150°F or less.

## Maximum Flow Capacity

- For dryers without an aftercooler installed upstream  
Flow capacity in scfm (m<sup>3</sup>/min) @ 180°F, 82°C inlet temperature, 160°F, 71°C inlet pressure dew point, 95°F, 35°C ambient temperature, and less than 5 psi, 0.35 kgf/cm<sup>2</sup> pressure drop.
- For dryers with an aftercooler installed upstream  
Flow capacity in scfm (m<sup>3</sup>/min) @ 100°F, 38°C inlet temperature, 100°F, 38°C inlet pressure dew point, 100°F, 38°C ambient temperature, and less than 10 psi, 0.7 kgf/cm<sup>2</sup> pressure drop.

### 60 HZ

Inlet Pressure psig (kgf/cm <sup>2</sup> )	175 (12.3)	150 (10.6)	125 (8.8)	100 (7.0)	
Model	20	23 (0.65)	22 (0.62)	20 (0.57)	18 (0.51)
	25	29 (0.82)	27 (0.76)	25 (0.71)	23 (0.65)
	35	41 (1.16)	38 (1.08)	35 (0.99)	32 (0.91)
	50	58 (1.64)	54 (1.53)	50 (1.42)	45 (1.27)
	75	87 (2.46)	81 (2.29)	75 (2.12)	68 (1.93)
	125	145 (4.12)	135 (3.82)	125 (3.54)	114 (3.23)

### 60 HZ

Inlet Pressure psig (kgf/cm <sup>2</sup> )	175 (12.3)	150 (10.6)	125 (8.8)	100 (7.0)	
Model	20	32 (0.91)	30 (0.85)	28 (0.79)	25 (0.71)
	25	40 (1.13)	37 (1.05)	34 (0.96)	31 (0.88)
	35	55 (1.56)	51 (1.44)	47 (1.33)	43 (1.22)
	50	78 (2.21)	73 (2.07)	67 (1.90)	61 (1.73)
	75	118 (3.34)	110 (3.12)	102 (2.89)	92 (2.61)
	125	197 (5.58)	183 (5.18)	170 (4.82)	155 (4.39)

# GENERAL ARRANGEMENT DRAWINGS

Model HTDN 20

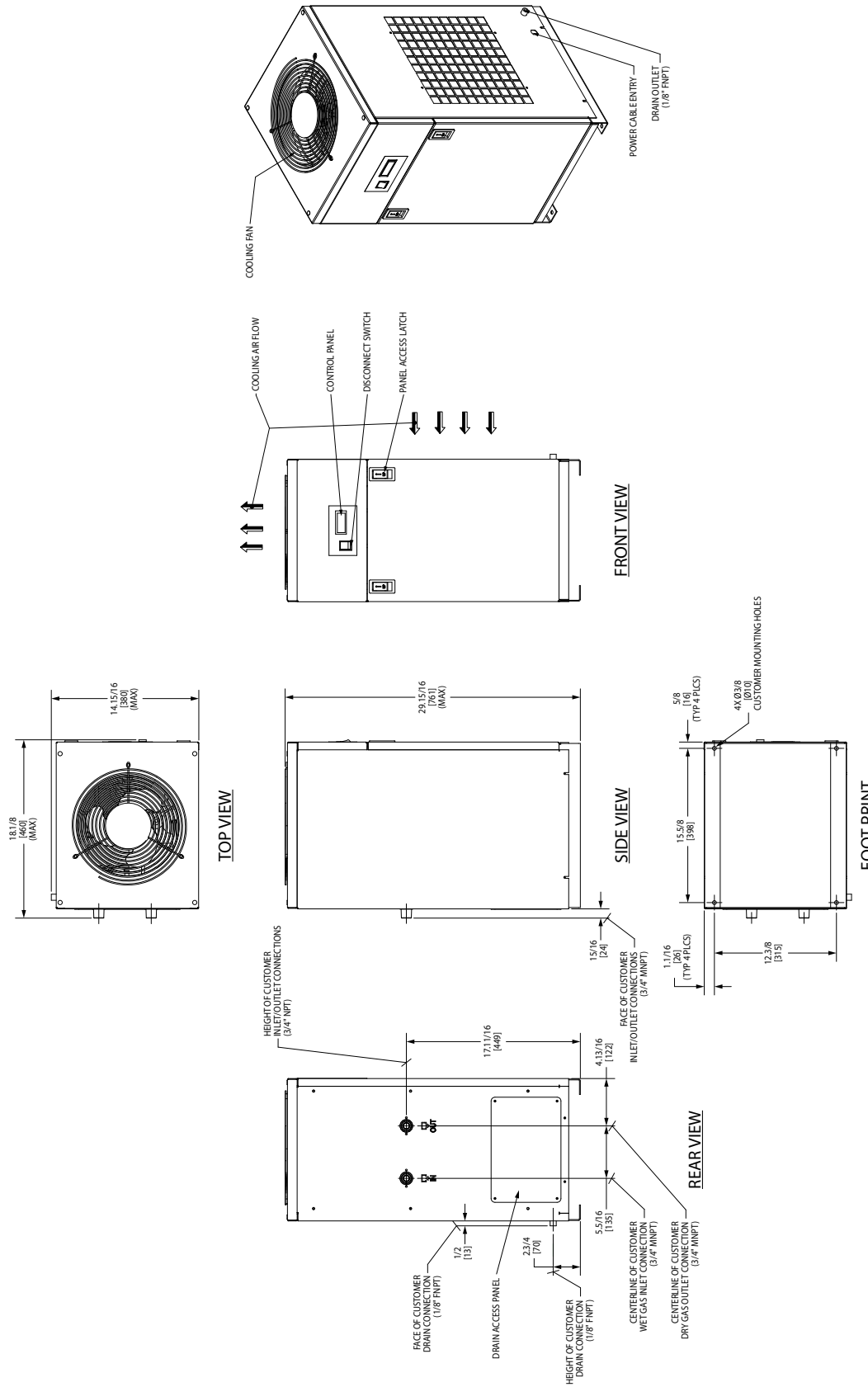

**NOTES:**

1. Install in a clean, well ventilated area to reduce dirt and dust on the condenser coils.
2. For cooling air flow and maintenance purposes, recommended clearance around unit is 2 feet (609.6 mm).
3. Installation constraints. On-site assembly of piping, tubing and/or electrical connections, are the responsibility of the customer/owner.

**SERVICE:**

Compressed Air

**DRYER INFORMATION:**

Inlet Air Flow: 20 SCFM | 0.5 Nm<sup>3</sup>/min  
 Connections: 3/4" MNPT  
 Drain Connection: 1/8" FNPT  
 Refrigerant: R134A  
 Electrical: 115V/1PH/60HZ  
 Weight: 95.71 LBS. / 42.5 KG

# GENERAL ARRANGEMENT DRAWINGS

Model HTDN 25

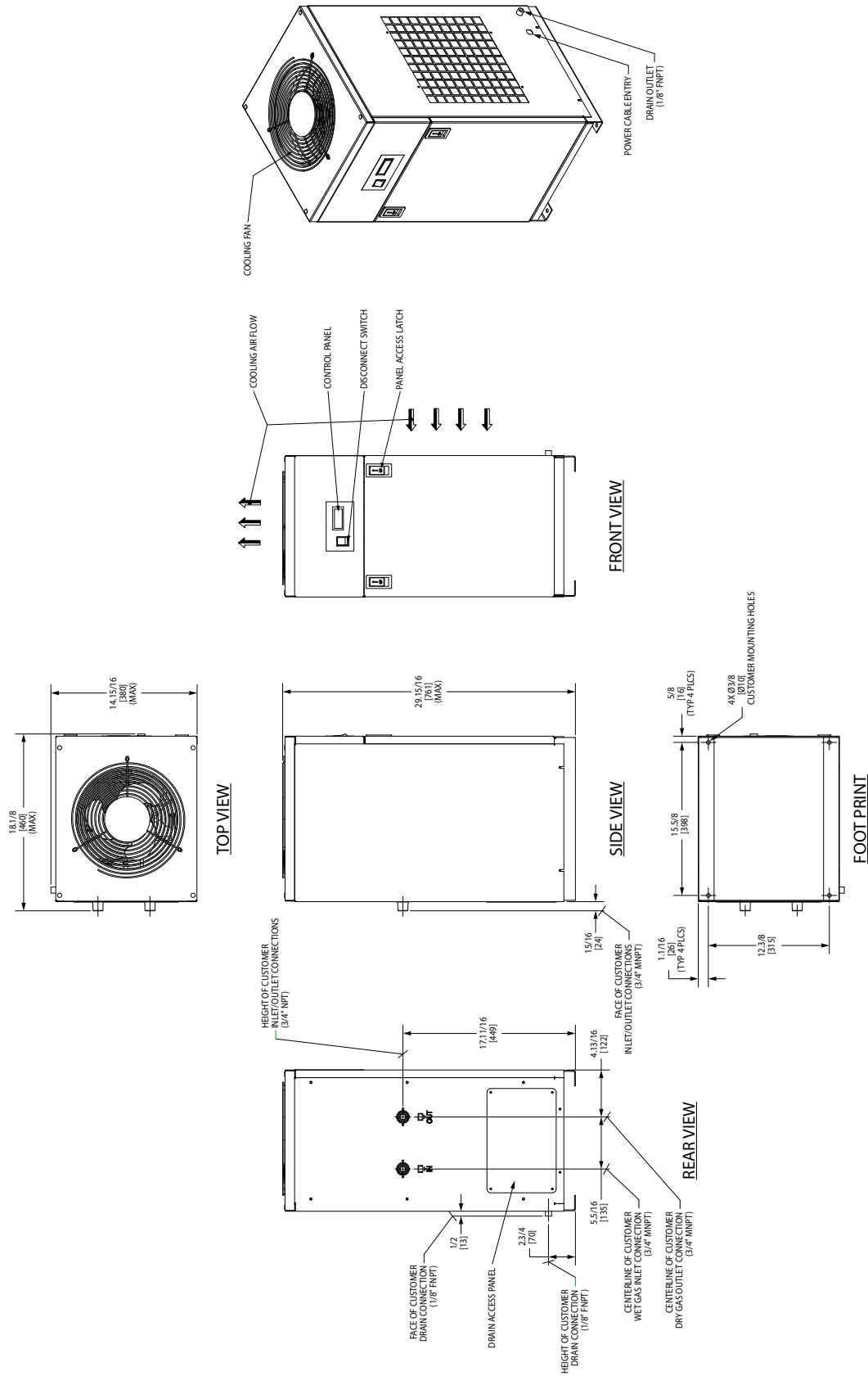

**SERVICE:**  
Compressed Air

**DRYER INFORMATION:**  
Inlet Air Flow: 25 SCFM | 0.7 Nm<sup>3</sup>/min  
Connections: 3/4" MNPT  
Drain Connection: 1/8" FNPT  
Refrigerant: R134A  
Electrical: 115V/1PH/60HZ  
Weight: 95.71 LBS. / 42.5 KG

- NOTES:**
1. Install in a clean, well ventilated area to reduce dirt and dust on the condenser coils.
  2. For cooling air flow and maintenance purposes, recommended clearance around unit is 2 feet (609.6 mm).
  3. Installation constraints: On-site assembly of piping, tubing and/or electrical connections, are the responsibility of the customer/owner.

# GENERAL ARRANGEMENT DRAWINGS

Model HTDN 35

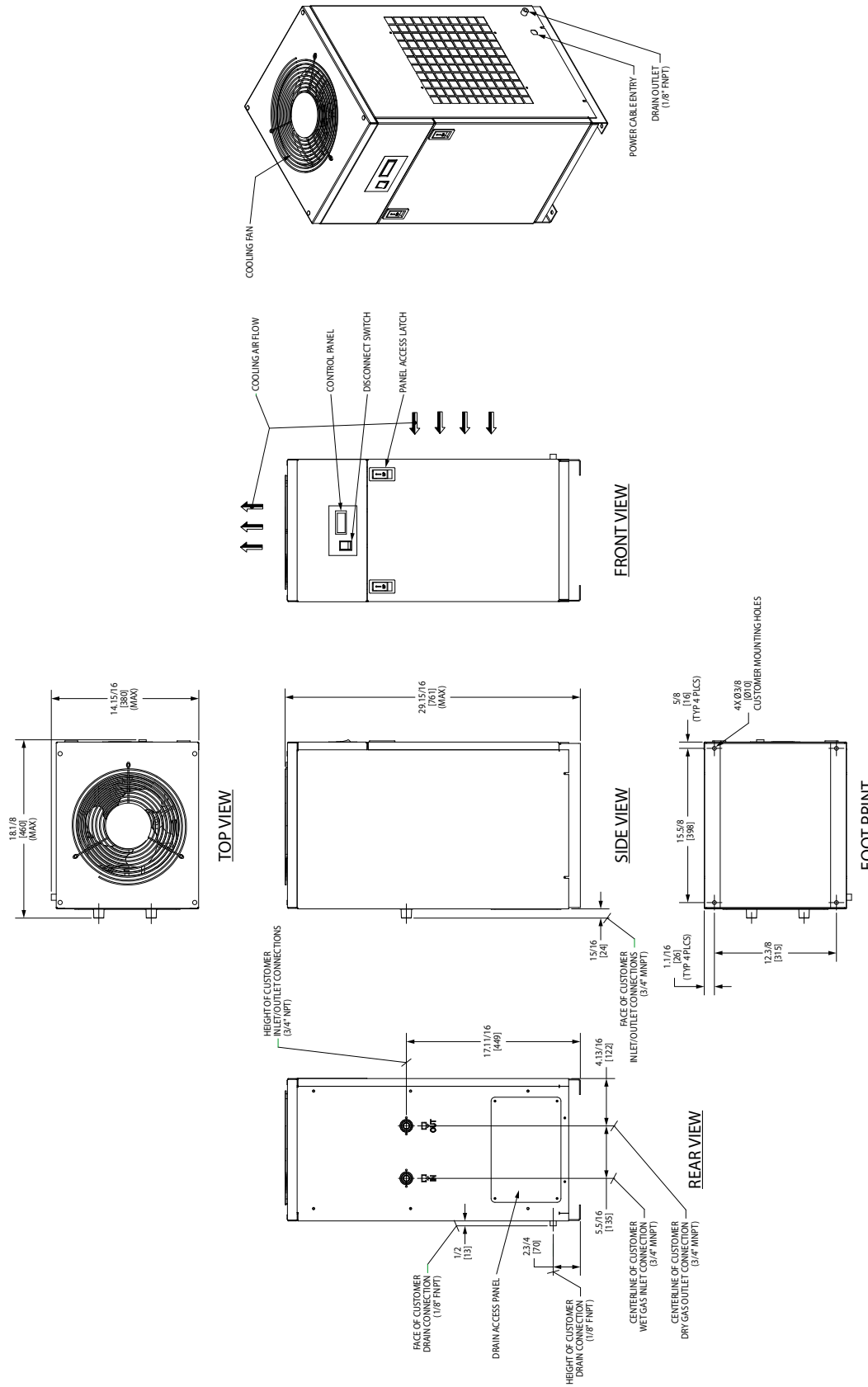

**SERVICE:**  
Compressed Air

**DRYER INFORMATION:**  
Inlet Air Flow: 35 SCFM | 0.9 Nm<sup>3</sup>/min  
Connections: 3/4" MNPT  
Drain Connection: 1/8" FNPT  
Refrigerant: R407C  
Electrical: 115V/1PH/60HZ  
Weight: 99.2 LBS. / 45 KG

- NOTES:**
1. Install in a clean, well ventilated area to reduce dirt and dust on the condenser coils.
  2. For cooling air flow and maintenance purposes, recommended clearance around unit is 2 feet (609.6 mm).
  3. Installation constraints. On-site assembly of piping, tubing and/or electrical connections, are the responsibility of the customer/owner.

# GENERAL ARRANGEMENT DRAWINGS

Model HTDN 50

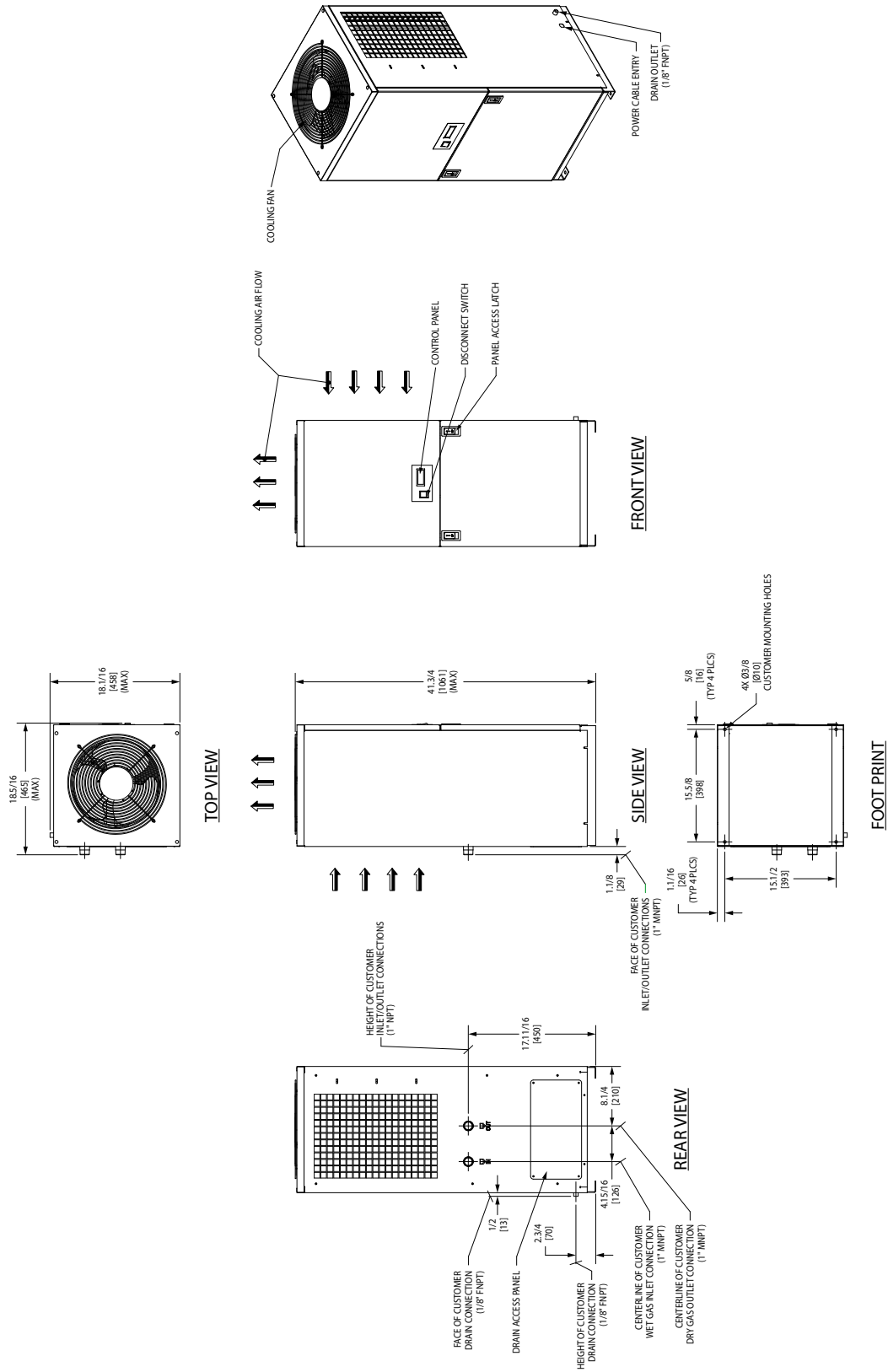

**SERVICE:**  
Compressed Air

**DRYER INFORMATION:**  
Inlet Air Flow: 50 SCFM | 1.3 Nm<sup>3</sup>/min  
Connections: 1" MNPT  
Drain Connection: 1/8" FNPT  
Refrigerant: R407C  
Electrical: 115V/1PH/60HZ  
Weight: 119.1 LBS. / 54 KG

- NOTES:**
1. Install in a clean, well ventilated area to reduce dirt and dust on the condenser coils.
  2. For cooling air flow and maintenance purposes, recommended clearance around unit is 2 feet (609.6 mm).
  3. Installation constraints: On-site assembly of piping, tubing and/or electrical connections, are the responsibility of the customer/owner.

# GENERAL ARRANGEMENT DRAWINGS

Model HTDN 75

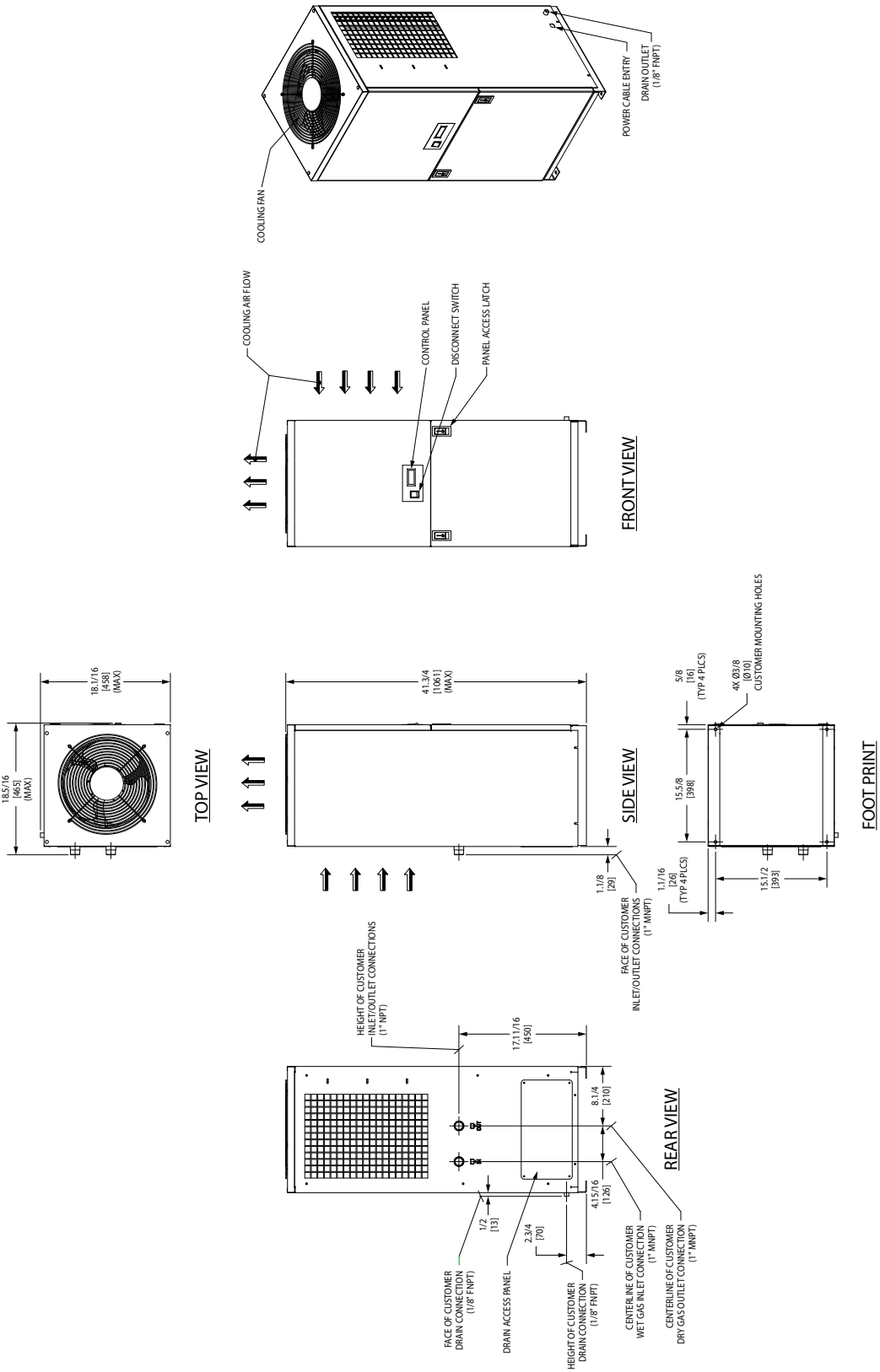

**SERVICE:**  
Compressed Air

**DRYER INFORMATION:**  
Inlet Air Flow: 75 SCFM | 2.0 Nm<sup>3</sup>/min  
Connections: 1" MNPT  
Drain Connection: 1/8" FNPT  
Refrigerant: R407C  
Electrical: 115V/1PH/60HZ  
Weight: 123.5 LBS. / 56 KG

- NOTES:**
1. Install in a clean, well ventilated area to reduce dirt and dust on the condenser coils.
  2. For cooling air flow and maintenance purposes, recommended clearance around unit is 2 feet (609.6 mm).
  3. Installation constraints. On-site assembly of piping, tubing and/or electrical connections, are the responsibility of the customer/owner.

# GENERAL ARRANGEMENT DRAWINGS

Model HTDN 125

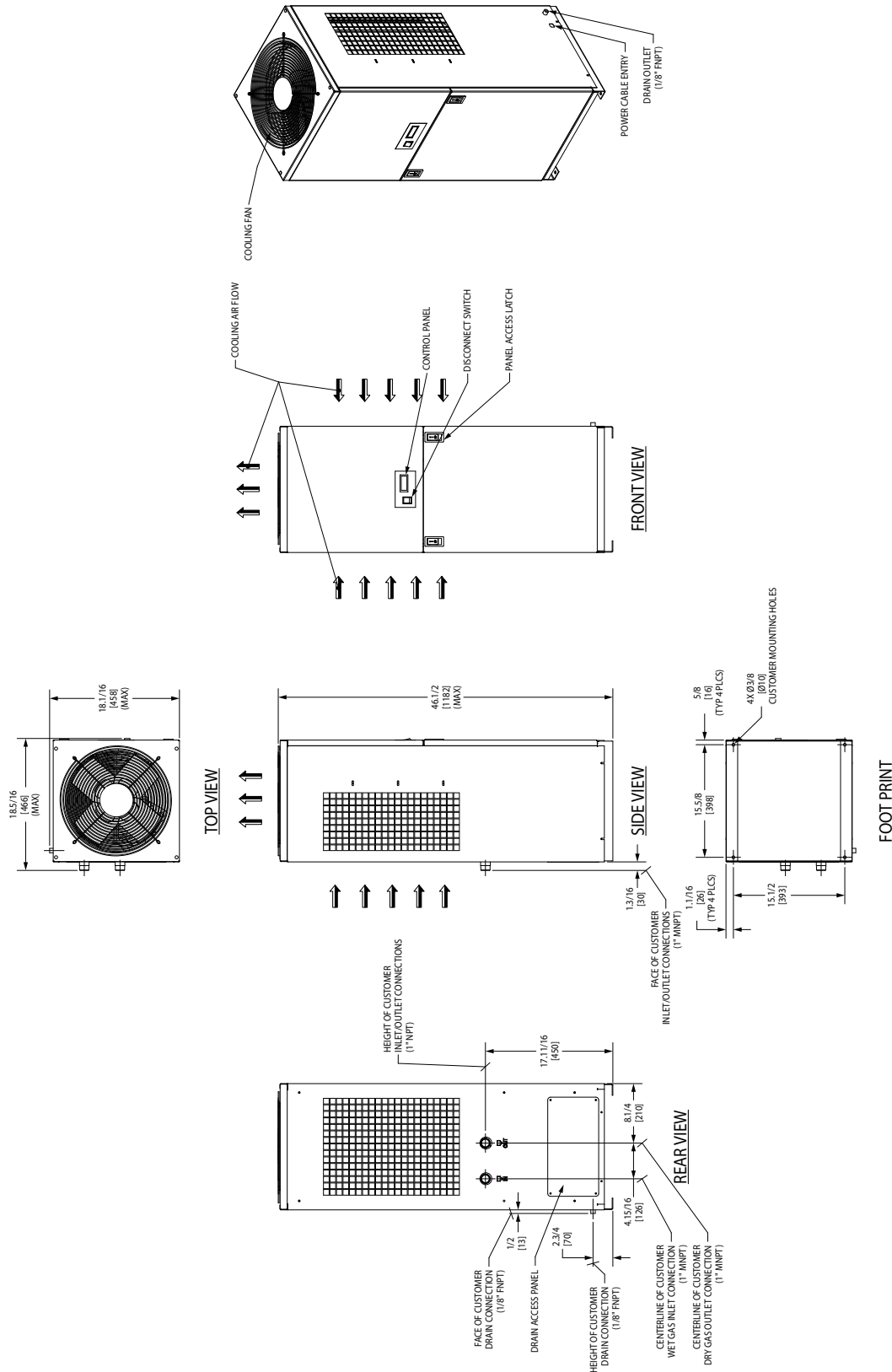

## NOTES:

1. Install in a clean, well ventilated area to reduce dirt and dust on the condenser coils.
2. For cooling air flow and maintenance purposes, recommended clearance around unit is 2 feet (609.6 mm).
3. Installation constraints: On-site assembly of piping, tubing and/or electrical connections, are the responsibility of the customer/owner.

## SERVICE:

Compressed Air

## DRYER INFORMATION:

Inlet Air Flow: 125 SCFM | 3.3 Nm<sup>3</sup>/min  
 Connections: 1" MNPT  
 Drain Connection: 1/8" FNPT  
 Refrigerant: R407C  
 Electrical: 230V/1PH/60HZ  
 Weight: 146.6 LBS. / 66.5 KG

# ELECTRICAL SCHEMATICS

Models HTDN 20 and HTDN 25

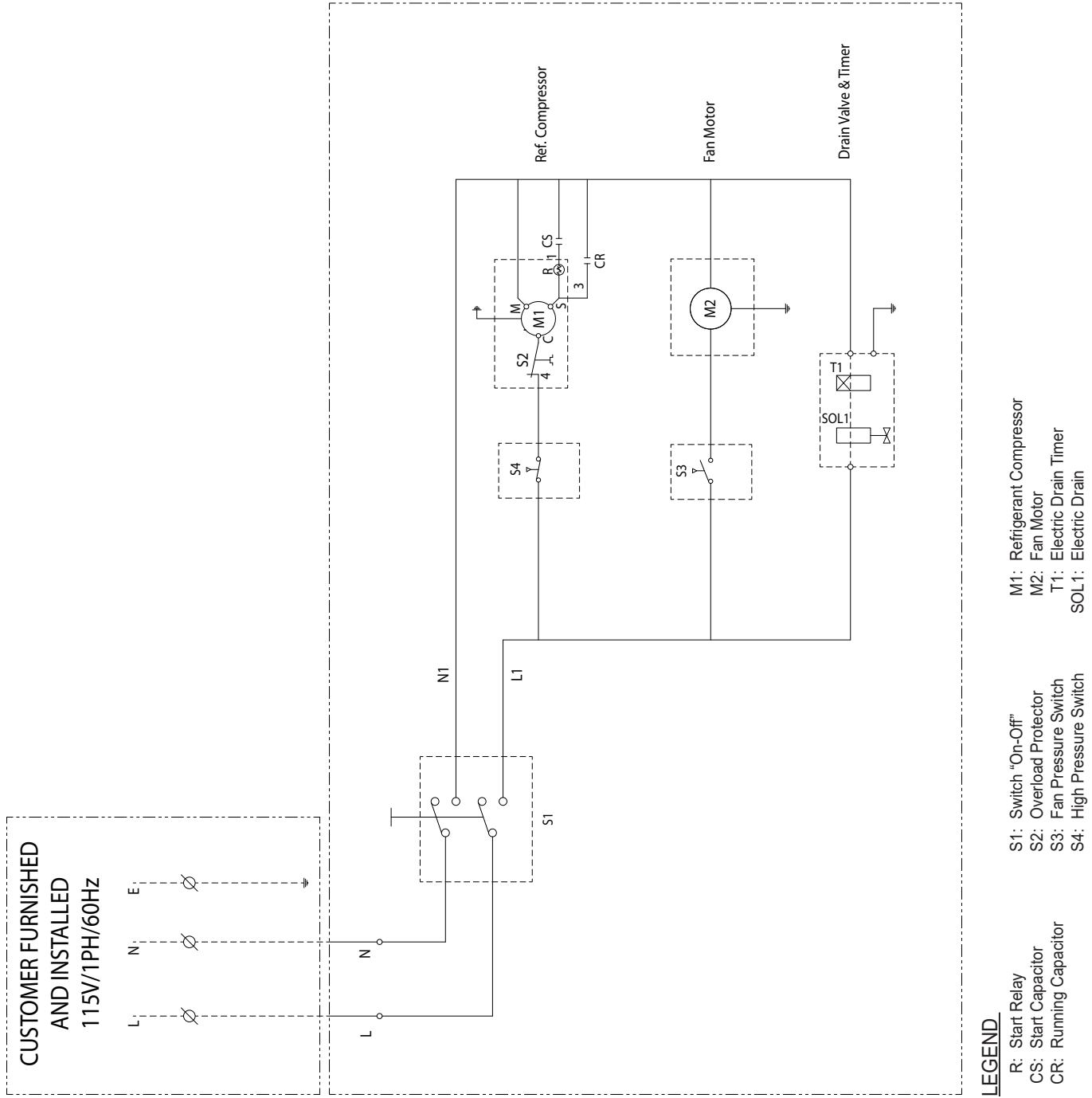

## LEGEND

- R: Start Relay
- CS: Start Capacitor
- CR: Running Capacitor
- S1: Switch "On-Off"
- S2: Overload Protector
- S3: Fan Pressure Switch
- S4: High Pressure Switch
- M1: Refrigerant Compressor
- M2: Fan Motor
- T1: Electric Drain Timer
- SOL1: Electric Drain



# ELECTRICAL SCHEMATICS

Models HTDN 35, HTDN 50, and HTDN 75

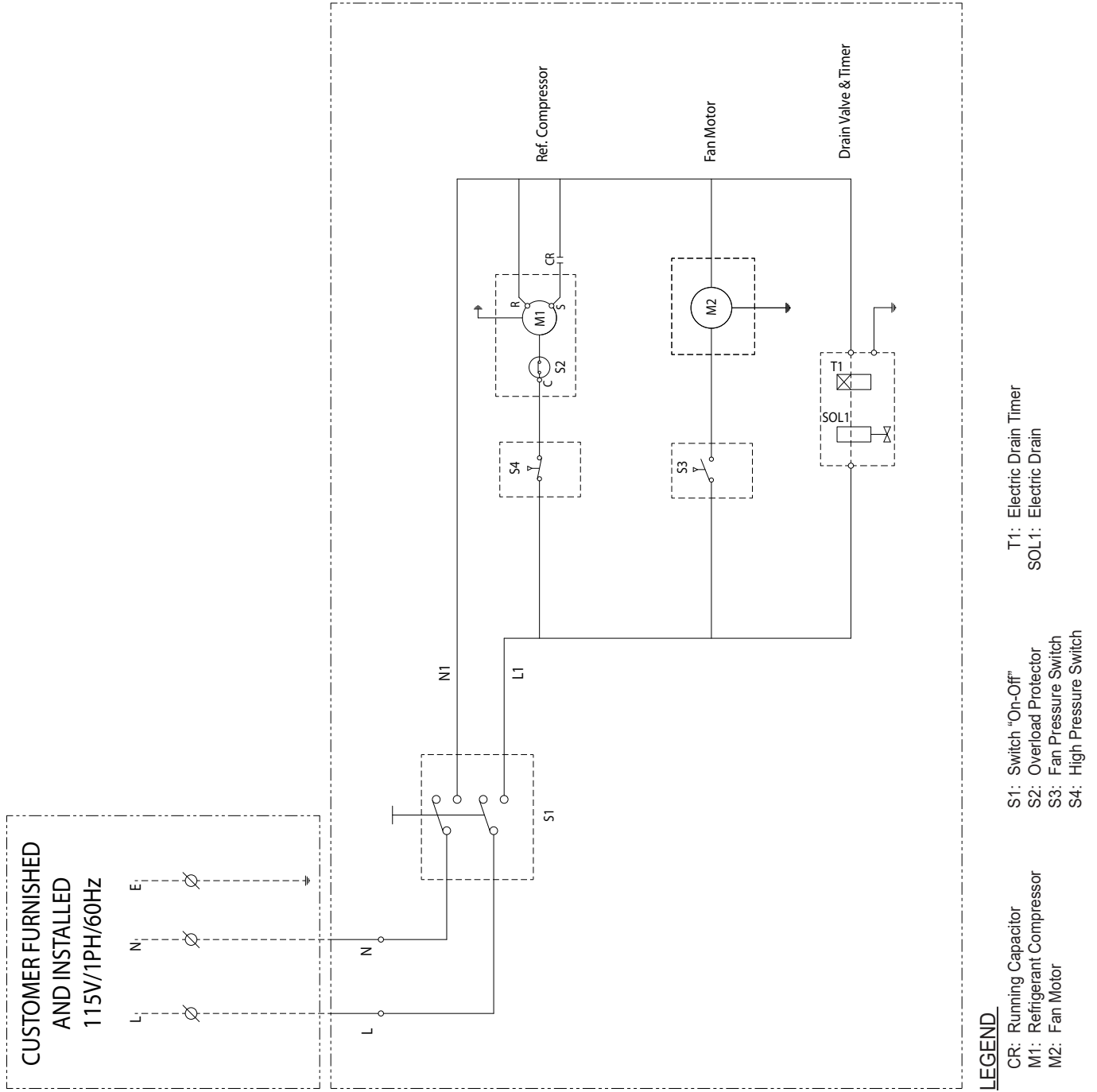

# ELECTRICAL SCHEMATICS

Model HTDN 125

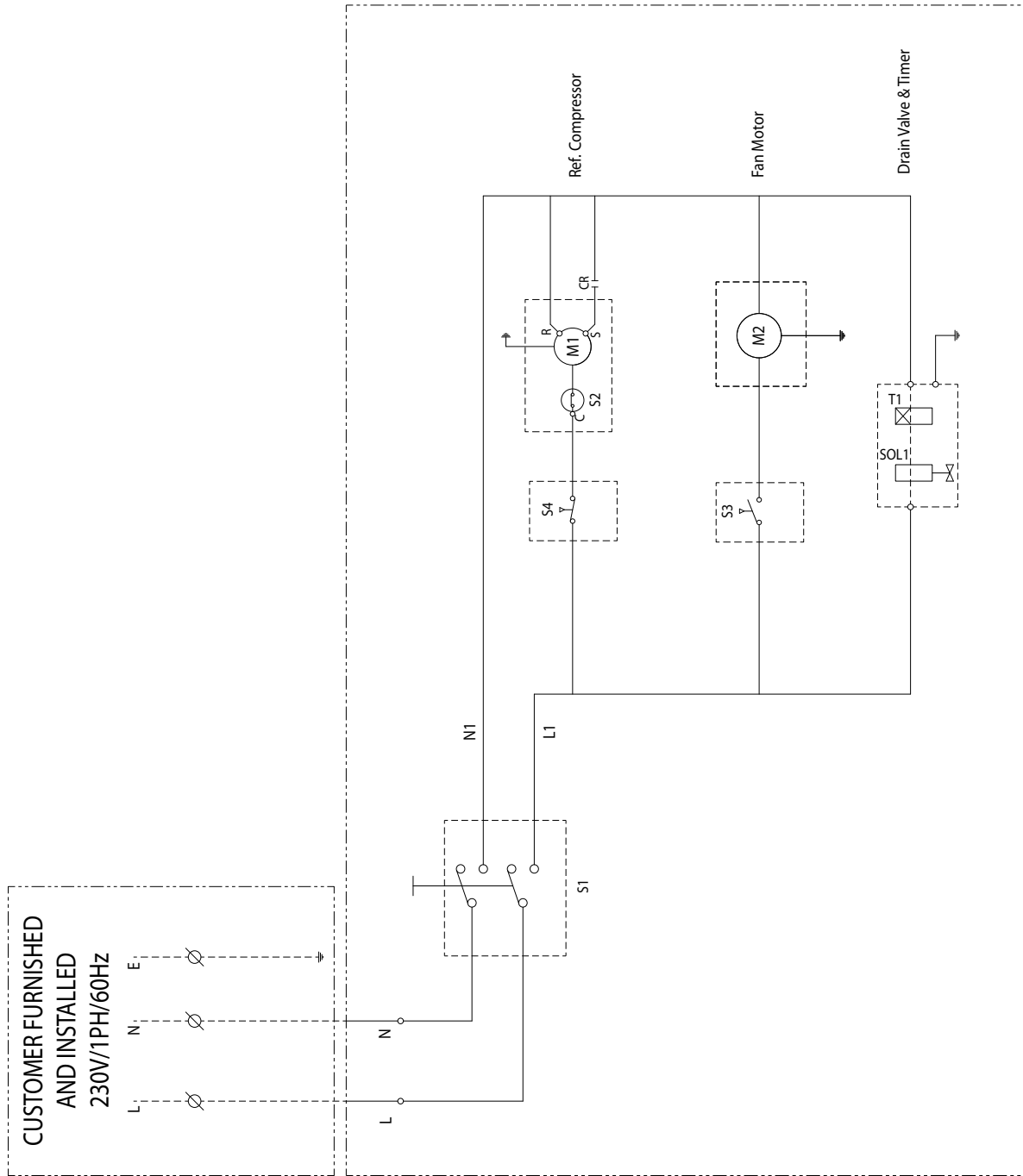

## LEGEND

- |                            |                          |
|----------------------------|--------------------------|
| CR: Running Capacitor      | T1: Electric Drain Timer |
| M1: Refrigerant Compressor | SOL1: Electric Drain     |
| M2: Fan Motor              | S1: Switch "On-Off"      |
|                            | S2: Overload Protector   |
|                            | S3: Fan Pressure Switch  |
|                            | S4: High Pressure Switch |

# AIR AND REFRIGERANT FLOW SCHEMATIC

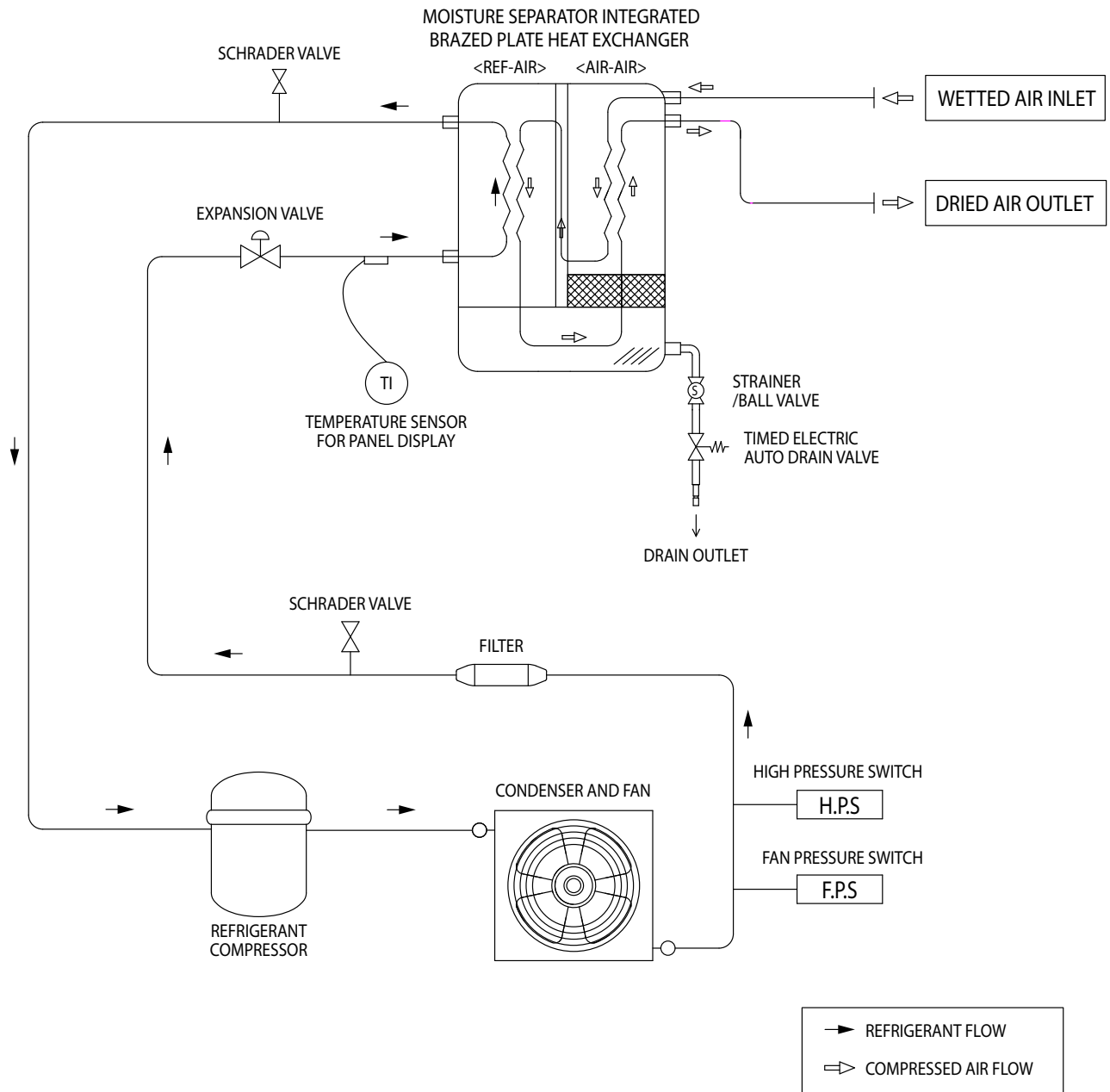

## REPLACEMENT PARTS

	HTDN 20	HTDN 25	HTDN 35	HTDN 50	HTDN 75	HTDN 125
<b>Part Name</b>						
Heat Exchanger	7440414	7440414	7440415	7440416	7440417	7440424
Refrigerant Compressor	7440070	7440070	7440418	7440418	7440245	7433663
Condenser	7440044	7440044	7440044	7440045	7440045	7439968
Fan Motor	3161257	3161257	3161257	3161243	3161243	7433673
Fan Blade	7440419	7440419	7440419	7440420	7440420	7440421
Fan Grill (Ext.)	7426016	7426016	7426016	7426017	7426017	7426018
Fan Pressure Switch	3161274	3161274	3146975	3146975	3146975	3146975
High Pressure Switch	3161273	3161273	7433678	7433678	7433678	7433678
Constant Pressure Valve	3161271	3161271	3161271	3041920	3041920	3041920
Schrader Valve	7419308	7419308	7419308	7419308	7419308	7419308
Filter Dryer	3142596	3142596	3142596	7433676	7433676	7433676
Electronic Drain Valve/Valve Coil & Body	7442841	7442841	7442841	7442841	7442841	7440422
On/Off Switch	3245021	3245021	3245021	3245021	3245021	3245021
Dew Point Indicator	7440423	7440423	7440423	7440423	7440423	7440423
Compressor OLP	7440255	7440255	-	-	-	-
Start Capacitor	7433696	7433696	-	-	-	-
Start Relay	7440256	7440256	-	-	-	-
Run Capacitor	7440425	7440425	7440259	7440259	7440259	3142606

Phone: +1 724 745 1555  
 Email: [ft.dehydration.order.entry@spxflow.com](mailto:ft.dehydration.order.entry@spxflow.com)  
 Web: [www.spxflow.com/deltech](http://www.spxflow.com/deltech)

## MAINTENANCE KITS

Model	Kit Components	HTDN 20	HTDN 25	HTDN 35	HTDN 50	HTDN 75	HTDN 125
Standard Kit	Drain Valve Repair Kit, Y-Strainer Screen	7477695	7477695	7477695	7477696	7477696	7477697
Standard Kit with Filtration Package	Drain Valve Repair Kit, Y-Strainer Screen, Prefilter Element, Afterfilter Element, Filter Drain (2)	7477722	7477722	7477722	7477723	7477723	7477724

Phone: +1 724 745 1555  
 Email: [ft.dehydration.order.entry@spxflow.com](mailto:ft.dehydration.order.entry@spxflow.com)  
 Web: [www.spxflow.com/deltech](http://www.spxflow.com/deltech)



## **WARRANTY**

The manufacturer warrants the product it manufactures, when properly installed, operated, applied, and maintained in accordance with procedures and recommendations outlined in manufacturer's instruction manuals, will be free from defects in material or workmanship for a period as specified below, provided such defect is discovered and brought to the manufacturer's attention within the aforesaid warranty period.

The manufacturer will repair or replace any product or part determined to be defective by the manufacturer within the warranty period, provided such defect occurred in normal service and not as a result of misuse, abuse, neglect or accident. Normal maintenance items requiring routine replacement are not warranted. The warranty covers parts and labor for the warranty period unless otherwise specified. Repair or replacement shall be made at the factory or the installation site, at the sole discretion of the manufacturer. Although not required for warranty consideration, it is recommended that the manufacturer be contacted prior to doing any warranty related service work. This action will provide guidance and instruction on the repair often times authorization to perform the work. **NOTE:** The manufacturer reserves the right to repair, replace in the case of warranty approval or reject the warranty claim once submitted.

Unauthorized service and use of unauthorized or pirated parts voids the warranty and any resulting charges or subsequent claim will not be paid. Products repaired or replaced under warranty shall be warranted for the unexpired portion of the warranty applying to the original product.

The foregoing is the exclusive remedy of any buyer of the manufacturer's product. The maximum damages liability of the manufacturer is the original purchase price of the product or part.

THE FOREGOING WARRANTY IS EXCLUSIVE AND IN LIEU OF ALL OTHER WARRANTIES, WHETHER WRITTEN, ORAL, OR STATUTORY, **AND IS EXPRESSLY IN LIEU OF THE IMPLIED WARRANTY OF MERCHANTABILITY AND THE IMPLIED WARRANTY OF FITNESS FOR A PARTICULAR PURPOSE.** THE MANUFACTURER SHALL NOT BE LIABLE FOR LOSS OR DAMAGE BY REASON OF STRICT LIABILITY IN TORT OR ITS NEGLIGENCE IN WHATEVER MANNER INCLUDING DESIGN, MANUFACTURE OR INSPECTION OF THE EQUIPMENT OR ITS FAILURE TO DISCOVER, REPORT, REPAIR, OR MODIFY LATENT DEFECTS INHERENT THEREIN. THE MANUFACTURER, HIS REPRESENTATIVE OR DISTRIBUTOR SHALL NOT BE LIABLE FOR LOSS OF USE OF THE PRODUCT OR OTHER INCIDENTAL OR CONSEQUENTIAL COSTS, EXPENSES, OR DAMAGES INCURRED BY THE BUYER, WHETHER ARISING FROM BREACH OF WARRANTY, NEGLIGENCE OR STRICT LIABILITY IN TORT.

Please note that the manufacturer's warranty for this product is intended to cover manufacturing defects and therefore does not cover consumable components (desiccants, filter elements, soft goods, standard maintenance kit wear items, etc.) or components that require periodic user adjustment (expansion valve, hot gas bypass valve or cooling water regulating valve) or calibration (dew point elements/sensors, gauge calibration, etc.)

### **Warranty Period**

Parts and labor for two (2) years from the date of shipment from the factory.

**AUTHORIZATION FROM THE SERVICE DEPARTMENT IS NECESSARY BEFORE MATERIAL IS RETURNED TO THE FACTORY OR IN-WARRANTY REPAIRS ARE MADE.**

**SERVICE DEPARTMENT: (724) 746-1100**

## HTDN Series

Refrigerated Type Compressed Air Dryers

Models: HTDN 20, HTDN 25, HTDN 35,  
HTDN 50, HTDN 75, HTDN 125

# SPXFLOW<sup>®</sup>

**SPX FLOW, INC.**

4647 S.W. 40th Avenue

Ocala, Florida 34474-5788 U.S.A.

P: (724) 745-1555

E: [ft.dehydration.order.entry@spxflow.com](mailto:ft.dehydration.order.entry@spxflow.com)

[www.spxflow.com/deltech](http://www.spxflow.com/deltech)

Improvements and research are continuous at SPX FLOW, Inc.

Specifications may change without notice.

ISSUED 10/2019 Form No.: 7477625 Revision: None

COPYRIGHT ©2019 SPX FLOW, Inc.