

DHP Series

High Pressure Refrigerated Type Compressed Air Dryer
Models: DHP130, DHP200, DHP300, DHP500, DHP750, DHP1000

FORM NO.: 5003971 REVISION: 07/2016

READ AND UNDERSTAND THIS MANUAL PRIOR TO OPERATING OR SERVICING THIS PRODUCT.

CONTENTS

GENERAL SAFETY INFORMATION	1
RECEIVING, MOVING, AND UNPACKING	1
1.0 INSTALLATION	2
1.1 Location	2
1.2 Mounting	3
1.3 Piping Connections	3
1.4 Electrical Connections	3
1.5 Moisture Separator	3
2.0 OPERATION	4
2.1 Minimum/Maximum Operating Conditions	4
2.2 Start-up	4
2.3 Timer Drain	4
2.4 Timer Drain Programming Mode.....	5
2.5 Operating Check Points	5
3.0 MAINTENANCE	6
3.1 Daily	6
3.2 Weekly	6
3.3 Monthly	6
3.4 Annually	6
4.0 TROUBLESHOOTING GUIDE	7
5.0 REFERENCE	8
5.1 Sizing	8
5.2 Engineering Data	9
6.0 DIMENSIONS / WEIGHTS	10
7.0 DRAWINGS	11
7.1 Process Gas / Refrigeration Flow Diagram: Models DHP130 and DHP200.....	11
7.2 Process Gas / Refrigeration Flow Diagram: Models DHP300 through DHP1000.....	12
7.3 Wiring Diagram: Models DHP130 and DHP200 (115 or 208-230V/60 Hz, 100 or 240V/50 Hz).....	13
7.4 Wiring Diagram: Models DHP300 through DHP750 (230-400-460V/3/50-60 Hz)	14, 15
7.5 Wiring Diagram: Model DHP1000 (230-400-460V/3/50-60 Hz).....	16, 17
7.6 Wiring Diagram: Models DHP300 through DHP1000 (575-460/3/60 Transformer Pack).....	18
8.0 REPLACEMENT PARTS LIST	19
8.1 Replacement Parts	19
8.2 Maintenance Kits	19
WARRANTY	21

GENERAL SAFETY INFORMATION

1. PRESSURIZED DEVICES:

This equipment is a pressure containing device.

- Do not exceed maximum operating pressure as shown on equipment serial number tag.
- Make sure equipment is depressurized before working on or disassembling it for service.



2. ELECTRICAL:

This equipment requires electricity to operate.

- Install equipment in compliance with all applicable electrical codes.
- Standard equipment is supplied with electrical enclosures not intended for installation in hazardous environments.
- Disconnect power supply to equipment when performing any electrical service work.



3. BREATHING AIR:

- Air treated by this equipment may not be suitable for breathing without further purification.

Refer to applicable standards and specifications for the requirements for breathing quality air.

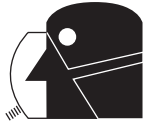

RECEIVING, MOVING, AND UNPACKING

A. RECEIVING

This shipment has been thoroughly checked, packed and inspected before leaving our plant. It was received in good condition by the carrier and was so acknowledged.

Check for Visible Loss or Damage. If this shipment shows evidence of loss or damage at time of delivery to you, insist that a notation of this loss or damage be made on the delivery receipt by the carrier's agent.

B. UNPACKING

Check for Concealed Loss or Damage. When a shipment has been delivered to you in apparent good order, but concealed damage is found upon unpacking, notify the carrier immediately and insist on his agent inspecting the shipment. Concealed damage claims are not our responsibility as our terms are F.O.B. point of shipment.

C. MOVING

In moving or transporting dryer, do not tip dryer onto its side.

D. STORAGE/SHUT DOWN

CAUTION Dryer should not be stored outside (either packed or unpacked) or exposed to the weather. Damage to electrical and control components may result.

IMPORTANT: WATER-COOLED UNITS - If the unit is shut down in below freezing temperatures, the water-cooled condenser may freeze and cause permanent damage. Condenser must be drained when the unit is shut down.

IMPORTANT: Do not store dryer in temperatures above 130°F (54.4°C).

IMPORTANT: READ PRIOR TO STARTING THIS EQUIPMENT

1.0 INSTALLATION

1.1 Location

- A. For typical placement in a compressed air system, see drawing.
- B. Air compressor intake – Locate air compressor so that contaminants potentially harmful to the dryer (e.g. ammonia) are not drawn into the air system.
- C. Free Air Flow Clearances
 Front: 36 inches (914 mm)
 Back: 6 inches (152 mm)
 Sides: 36 inches (914 mm)
 Service - To facilitate maintenance leave 36 inches (914 mm) of clearance in front of dryer.
- D. Standard units are designed to operate in ambients:
 Air-cooled: 40 to 110°F (4 to 43°C).
 Water-cooled: 40 to 130°F (4 to 54°C).
- E. Installations in altitudes above 4500 feet (1370 meters)
 – Dryer is adjusted to operate in altitudes up to 4500 feet (1370 meters). If dryer is installed in an altitude above this, and has not been preset at the factory for this altitude, contact manufacturer's Service Department.

CAUTION There shall be no external forces or vibrations transmitted to the dryer inlet/outlet connections from the piping. External piping must be properly supported. The installation of a flexible connection or vibration dampener, within the air/gas stream, prior to the dryer is recommended to further reduce the possibility of damage from vibration or pulsations. Failure to do so may void the warranty.

NOTE: Outdoor installation – Standard units are designed for indoor installation. Contact manufacturer if installing outdoors.

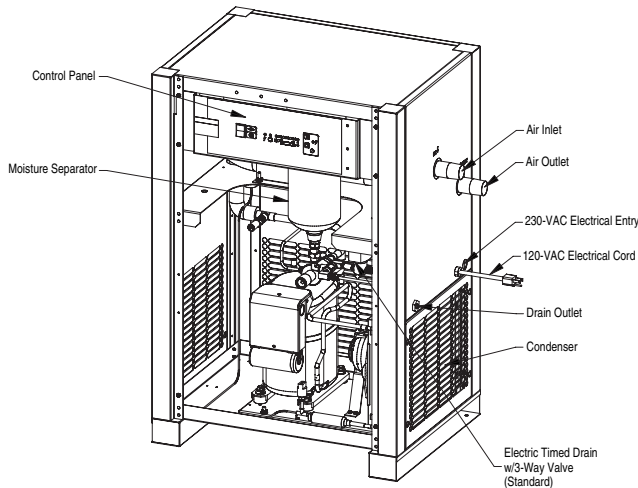
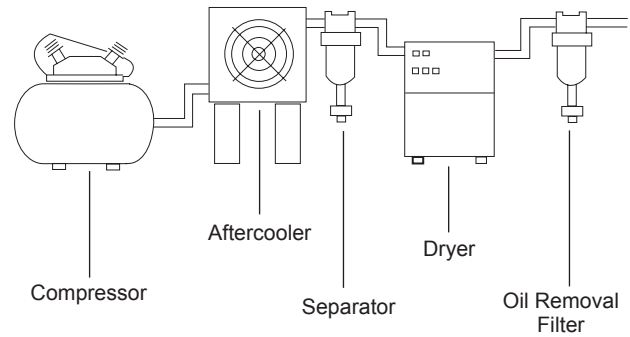

Models
DHP130 and DHP200

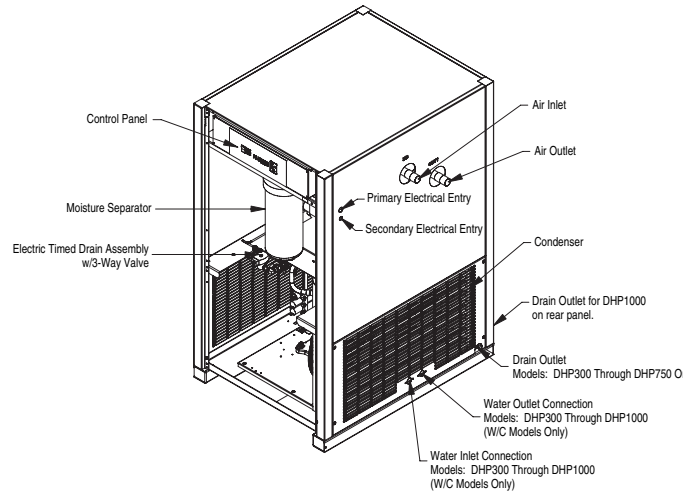

Models
DHP300, DHP500, DHP750, and DHP1000

1.2 Mounting

Mount the dryer on a level solid surface. Holes are provided in the dryer base to permanently mount the dryer to the floor.

1.3 Piping Connections

- A. Air Inlet - Connect compressed air line from air source to air inlet. (Reference markings on dryer or see call out drawing on page 10 for air inlet/outlet connection locations.)

NOTE: Use back-up wrench when making piping connections.

CAUTION There shall be no external forces or vibrations transmitted to the dryer inlet/outlet connections from the piping. External piping must be properly supported. The installation of a flexible connection or vibration dampener, within the air/gas stream, prior to the dryer is recommended to further reduce the possibility of damage from vibration or pulsations. Failure to do so may void the warranty.

WARNING Refer to Serial Number Tag for maximum working pressure. Do not exceed dryer's Maximum Working Pressure.

NOTE: Install dryer in air system at highest pressure possible (e.g. before pressure reducing valves).

NOTE: Install dryer at coolest compressed air temperature possible. Maximum inlet compressed air temperature: 120°F (49°C). If inlet air exceeds this temperature, precool the air with an aftercooler.

- B. Air Outlet – Connect air outlet to downstream air lines.

NOTE: Use back-up wrench when making piping connections.

CAUTION There shall be no external forces or vibrations transmitted to the dryer inlet/outlet connections from the piping. External piping must be properly supported. The installation of a flexible connection or vibration dampener, within the air/gas stream, prior to the dryer is recommended to further reduce the possibility of damage from vibration or pulsations. Failure to do so may void the warranty.

- C. Bypass piping – If servicing the dryer without interrupting the air supply is desired, piping should include inlet and outlet valves and an air bypass valve.
- D. Water cooled models – cooling water inlet and outlet
1. Connect cooling water supply to cooling water inlet.
 2. Connect cooling water return line to cooling water outlet connection.

NOTE: Strainer and water regulating valve are supplied on water cooled models.

1.4 Electrical Connections

IMPORTANT: Use copper supply wires only.

- A. Dryer is designed to operate on the voltage, phase, and frequency listed on the serial number tag.
- B. If dryer is supplied with a cord and plug, install in a receptacle of proper voltage.

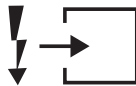

- C. Electrical entry on larger dryers is through a hole in the cabinet. It is located on the right side panel when facing the front of the unit. Connect power source to terminal strip in electrical enclosure as shown on the wiring diagram included with the dryer.

NOTE: Refrigeration condensing unit is designed to run continuously and should **NOT** be wired to cycle on/off with the air compressor.

1.5 Moisture Separator

- A. Separator has an external drain which automatically discharges collected condensate.



NOTE: It may be desirable to pipe the condensate from the Automatic Drain outlet to a suitable drain.

- B. For manual draining, convenient dryer depressurization, and drain valve maintenance, a three-way valve assembly is installed between the drain port on the moisture separator and the drain valve. On all models, the three-way valve is mounted to the bottom of the separator vessel using a pipe union. Review the following for proper drain function:

- Automatic Draining - Valve handle should be positioned parallel to the valve body (as shown), with the arrow on the handle pointing toward the drain valve. In this position, condensate will flow from the bowl to the drain valve.
- Drain Isolation (Shutdown) - Valve handle shall be turned perpendicular to the valve body (rotate 90°). In this position, condensate flow is shutoff.

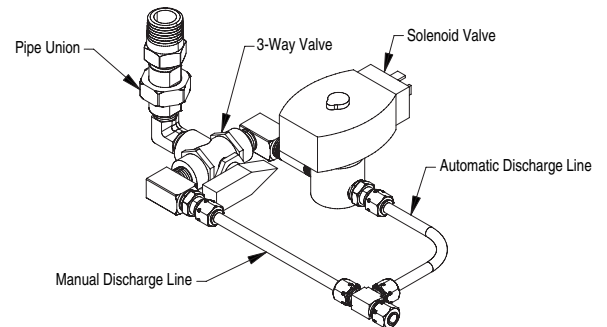

- Manual Draining - Drain valve handle shall be rotated slightly past the drain isolation position to allow throttling through the valve for manual discharge and depressurization.
- **NOTE:** The pipe union allows removal of the entire drain assembly. **However, the unit must be depressurized prior to disassembly or serious injury may occur.**

NOTE: Discharge is at system pressure. Drain line should be anchored.

NOTE: Condensate may contain oil. Comply with applicable laws concerning proper disposal.

2.0 OPERATION

2.1 Minimum/Maximum Operating Conditions

- Maximum inlet air pressure: 725 psig (50 barg)
- Minimum inlet air pressure: 15 psig (1.0 barg)
- Maximum inlet air temperature: 120°F (49°C)
- Maximum ambient temperature:
Air-cooled models: 110°F (43°C)
Water-cooled models: 130°F (54°C)
- Minimum ambient temperature: 40°F (4°C)

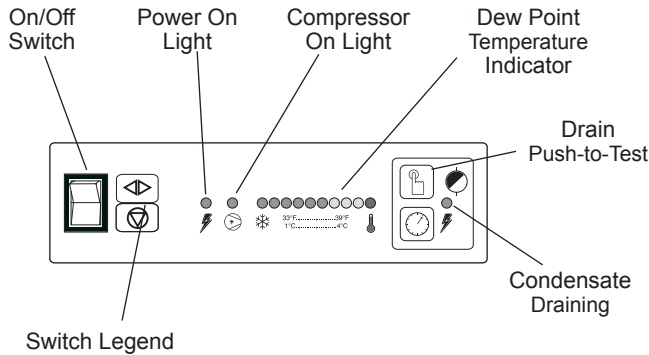

2.2 Start-up

IMPORTANT: Energize dryer disconnect switch (provided by others, see NEC) 24 hours before refrigeration compressor is started! Never use the disconnect switch to shut-down the dryer for an extended period of time (except for repair). Failure to follow these instructions may result in a non-warrantable compressor failure.

NOTE: It is recommended that dryer be started 15 minutes before compressed air flow begins.

NOTE: If there is no power to the control board for a period of two weeks or more, it may return to the default mode.

- Confirm On/Off Switch is in the "Off" position.
- Check for proper electrical voltage.
- Energize dryer disconnect switch (see IMPORTANT note above)
- For water-cooled models: after 24 hours, begin cooling water flow.
- Toggle ON/OFF switch to the ON position to energize dryer. Green power-on light will illuminate.
- Slowly pressurize unit air side by opening inlet isolation valve. Check for leaks.
- After 15 minutes, open outlet isolation valve slowly.
- Close air by-pass valve.

2.3 Timer Drain

NOTE: The Timer Drain LED level has been pre-programmed at the factory for your specific dryer model. Programming is based upon a minimum of 400 psig saturated inlet air pressure and maximum energy efficiency. The drain open time is fixed at one second and a small amount of air will be exhausted with each cycle. Generally, no adjustment to the timer is required.

▲ CAUTION If water is present downstream of the dryer, always verify that any condensate drains installed upstream of the dryer are draining properly before attempting to readjust the LED setting.

- For minimum inlet air pressures that fall between column values, the setting for the lower pressure is recommended. (i.e. select the 300 psi column values for 324 psi inlet pressure listed in Table 1.)
- Where the dryer is consistently operating at less than maximum capacity, it may be possible to increase the LED set point to minimize air loss. Discretionary adjustments to the dryer should only be made on a hot, humid day when the maximum expected air load is flowing through the dryer. Failure to do so may prevent the condensate from draining completely when operating under peak load conditions.

Table 1 Timed drain illuminated LED Settings

Dryer Model	Inlet Pressure				
	300	400*	500	600	725
DHP130	3	4	4	4	5
DHP200	3	3	4	4	4
DHP300	3	4	4	4	5
DHP500	3	3	3	4	4
DHP750	2	2	3	3	3
DHP1000	1	2	2	3	3

* Recommended and pre-programmed factory settings for each model dryer. Assumes inlet conditions with 120°F ambient and 10°F air-cooled aftercooler approach temperature.

Table 2 Timed drain illuminated LED Settings

LED Illuminated	Minutes between Drain Cycles
1 st	1
2 nd	3
3 rd	5
4 th	10
5 th	20
6 th	30
7 th	40
8 th	50
9 th	60

2.4 Timer Drain Programming Mode

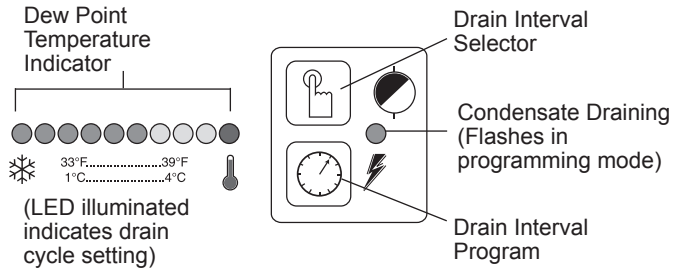

1. Press the “Drain Interval Program” button. The “Condensate Draining” LED will start to flash, and the illuminated LED on the “Dew Point Temperature Indicator” will identify the factory setting for “Minutes Between Drain Cycles.” (See Table 1)
2. Press and release the “Drain Interval Selector” button to sequence the “Minutes Between Drain Cycle LED’s” from left to right until reaching your selection. The “Red” LED is not used (Reference Table 2 for “Drain Cycle Intervals”)
3. To initiate the new setting, press the “Drain Interval Program” button (this will store the new setting and exit the program).
4. Exiting the Program will cause the Timer Drain to discharge and begin a new cycle.

NOTE: Failure to perform step 3 within 25 seconds of completing step 2 will cause the unit to revert back to the previous setting.

NOTE: In the event of a brief or extended period of power loss, the unit will retain the existing program setting and will begin a new cycle once power is reapplied. Had drain been ready to drain before the loss of power, the drain bowl’s capacity would prevent downstream flooding. Condensate will drain completely within a couple of cycles. (Manually pressing the “Push-to-Test” button would drain bowl immediately)

2.5 Operating Check Points

Check the following on a periodic basis:

- A. Green power on light is illuminated.
- B. Dew point indicator is in green area.
- C. Condensate is discharging from drain.

3.0 MAINTENANCE

3.1 Daily

- A. Check separator daily to be sure automatic drain is discharging.

3.2 Weekly

- A. Blow down separator weekly by pushing test button on control panel.

3.3 Monthly

- A. Condenser coil
 1. Air-cooled - clean off accumulated dust and dirt monthly or as necessary in dirty environments.
 2. Water-cooled - clean strainer monthly, more often if required. Shut off water, remove small plug to relieve pressure, then remove large plug to remove strainer. Clean strainer and replace.

3.4 Annually

NOTE: Prepackaged maintenance kits are available that include all necessary filter and timed drain valve components. Maintain maximum performance and efficiency with Genuine Parts. See page 19 for ordering information.

- A. Rebuild drain mechanism annually.
- B. Moisture Separator/Oil Removal Filter
 1. Replace filter element annually, or when pressure drop across dryer is excessive.
When removing liquids at rated flow conditions, an increase in pressure drop will occur as the separator/filter elements become loaded with solid particles.
 2. Procedure for Separator / Filter Element Replacement

⚠WARNING THIS FILTER IS A PRESSURE CONTAINING DEVICE. DEPRESSURIZE BEFORE SERVICING.

- a) Isolate dryer (close inlet and outlet valves if installed) or shut off air supply.
- b) Remove front panel and depressurize filter by slowly opening manual drain by-pass valve.
- c) Disconnect drain line from bottom of separator.
- d) Disassemble filter housing.
 - 1) For all models - remove the filter bowl, unscrewing it from the filter head by hand or strap wrench.
- e) Clean filter bowl.

- f) Remove and replace complete element.
 - 1) Unscrew the old filter element and discard. Also, discard the small o-ring that seals the filter to the filter assembly head.
- g) Install new filter element and bowl with new o-rings properly seated to head or bowl (dependent upon dryer size).
- h) Connect drain line and replace panel.
- i) Repressurize dryer and resume operation.

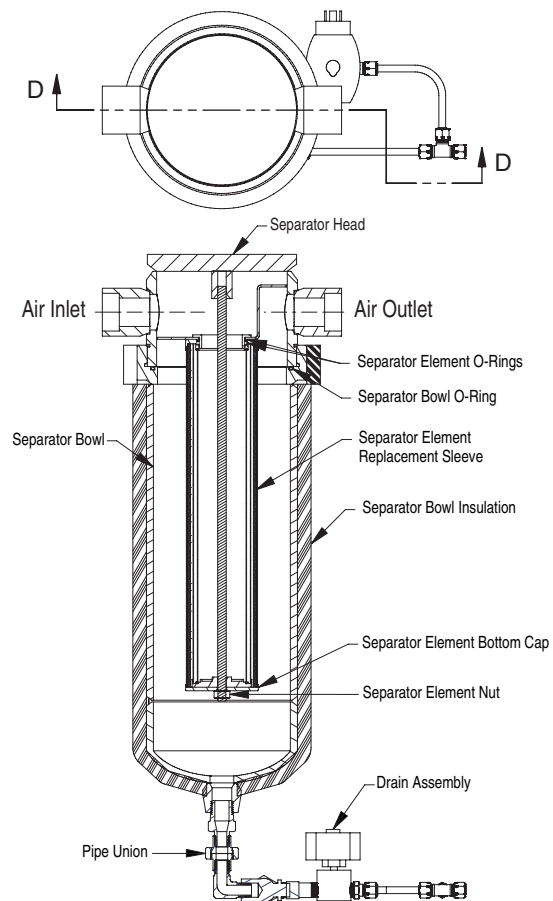

4.0 TROUBLESHOOTING GUIDE

SYMPTOM	POSSIBLE CAUSE(S)	CORRECTIVE ACTION
A) Water downstream of dryer	<ol style="list-style-type: none"> 1. Residual free moisture remaining in downstream pipelines 2. Air bypass system is open 3. Inlet and Outlet connections are reversed 4. Air lines downstream of dryer are exposed to temperatures below the dew point. 5. Excessive free moisture (bulk liquid) at dryer inlet. 6. Condensate not being drained Drain mechanism is clogged or inoperative. Drain line is restricted or frozen. Electric drains-timer not set to allow for sufficient condensate removal. 7. Dryer overloaded resulting in elevated dew point. 8. Refrigeration system not functioning 	<p>Blow out system with dry air</p> <p>Check valve positions Check for correct connection Insulate or heat trace air lines exposed to low ambients or dry air to lower dew point Install separator ahead of dryer</p> <p>Replace drain mechanism if inoperative.</p> <p>Open drain line. Electric drains-reset time so that all liquid is discharged Check inlet air temperature and pressure, flow rate (compressor capacity) and ambient air or water temperature. See D below</p>
B) High pressure drop across dryer	<ol style="list-style-type: none"> 1. Excessive air flow 2. Freezing of moisture in evaporator because of refrigeration system fault 3. Separator filter element clogged 	<p>Check flow rate See D below</p> <p>Replace filter element</p>
C) Dew point indicator in red area	<ol style="list-style-type: none"> 1. Dryer overloaded resulting in high air outlet temperature 2. Refrigeration system not functioning properly resulting in high air outlet temperature 	<p>See A 7</p> <p>See D below</p>
D) Refrigeration system not functioning properly <ol style="list-style-type: none"> 1. Power on light off 2. Compressor on light off 3. Refrigeration compressor cycles on and off 	<ol style="list-style-type: none"> a. Power failure b. Line disconnect switch open c. Blown fuses, open breaker d. Faulty wiring, loose terminals <ol style="list-style-type: none"> a. ON/OFF switch is "OFF" b. Line disconnect switch open c. Blown fuses, open breaker d. Faulty wiring, loose terminals <ol style="list-style-type: none"> a. High or low ambient conditions b. Air-cooled - Dirty, clogged condenser fins, obstructed flow across condenser, faulty fan motor or fan control switch. 	<p>Check for power to unit Close disconnect switch Check for continuity Have electrician check electrical connections.</p> <p>Turn switch "ON" Close disconnect switch Check for continuity Have electrician check electrical connections</p> <p>Check min./max. temperature ranges</p> <p>Clean condenser and check for free air flow, if problem persists contact qualified refrigeration repairman or manufacturer's service department.</p>

5.0 REFERENCE

5.1 Sizing

Determining dryer capacity at actual operating conditions

To determine the maximum inlet flow capacity of a dryer at various operating conditions, multiply the rated capacity from Table 1 by the multipliers shown in Table 2.

Example: How many scfm can an air-cooled model DHP300 handle when compressed air to be dried is at 350 psig and 90°F; ambient air temperature is 80°F?

Answer: $300 \times 1.19 \times 1.12 = 400$ scfm.

Table 1. Rated Capacity

Rated capacity (scfm) @ 725 psig inlet pressure, 100°F inlet temperature, and 100°F ambient temperature and 60 Hertz operation.

MODEL	RATED FLOW	
	(scfm)	m ³ /hr
DHP130	130	221
DHP200	200	340
DHP300	300	510
DHP500	500	850
DHP750	750	1275
DHP1000	1000	1700

Table 2. Capacity Adjustment Factors for Air Inlet Temperature and Pressure

INLET PRESSURES		INLET TEMPERATURES				
(psig)	(barg)	80°F 27°C	90°F 32°C	100°F 38°C	110°F 43°C	120°F 49°C
300 to 725	21 to 50	1.49	1.19	1.00	0.83	0.72

Table 3. Capacity Adjustment Factors for Ambient Air Temperature

AMBIENT TEMPERATURE °F (°C)	CAPACITY ADJUSTMENT FACTOR
80°F (27°C)	1.12
90°F (32°C)	1.06
100°F (38°C)	1.00
110°F (43°C)	0.94
Water-cooled (85°F, 29.4°C cooling water)	1.15

Table 4. Capacity Adjustment Factors for Electrical Frequency

50 Hertz	60 Hertz
0.83	1.00

5.2 Engineering Data

Models		DHP130	DHP200	DHP300	DHP500	DHP750	DHP1000	
Air System Data								
Maximum / Minimum Inlet Air Pressure (compressed air at inlet to dryer)		725 psig (50 barg) / 15 psig (1.0 barg)						
Maximum / Minimum Inlet Air Temperature (compressed air at inlet to dryer)		120°F (49°C) / 40°F (4°C)						
Maximum / Minimum Ambient Temperature		Air-cooled: 110°F (43°C) / 40°F (4°C), Water-cooled: 130°F (54°C) / 40°F (4°C)						
Outlet Air Temperature (nominal at rated conditions)		85°F (29.4°C)						
Refrigeration System Data								
Refrigeration Capacity @ 35°F Evaporator & 100°F Ambient (BTU/hr)		60 Hz	4820	6030	8900	15200	22000	30500
		50 Hz	4020	5690	7420	12700	18300	25400
Refrigerant Type		R-134A						
Refrigerant Charge		See Data Tag on Dryer						
Suction Pressure Setting - Hot Gas Bypass Valve (psig)		30.5 psig (2.1 barg)						
Compressor Control Ranges (out-in) (both air-cooled and water-cooled models)		High	N/A		281 - 190 psig (19.4 - 13.1 barg)			
		Low	N/A		22 - 34 psig (1.5 - 2.3 barg)			
Air-Cooled Condensers								
Air Flow Across Condenser (cfm) (air-cooled models)		60 Hz	300	450	710	1070	1680	2170
		50 Hz	250	370	590	890	1400	1810
Condenser Fan Switch Setting (in-out)		Fan 1	110 - 70 psig (7.6 - 4.8 barg)		113 - 78 psig (7.8 - 5.4 barg)			
		Fan 2	N/A			183 - 124 psig (12.6 - 8.6 barg)		
Water-Cooled Condensers								
Water Regulating Valve Setting		135 psig (9.3 barg)						
Required Available Water Pressure Differential		40 psig (2.8 barg) - minimum						
Flow Required with 85°F Cooling Water (gallons per minute)		60 Hz	N/A		1.3	2.1	3.0	3.6
		50 Hz	N/A		1.2	2.0	2.8	3.3
Electrical Data								
Nominal Voltage		115/1/60			208-230/3/60			
Min. - Max. Voltage		104 - 127			187 - 253			
Input Power @ Rated Flow (watts)		932	1280	1255	1962	2910	4120	
Rated Load Amps**		10.2	13.0	7.5	10.4	13.9	22.1	
Locked Rotor Amps**		51.0	70.0	51.0	66.0	88.0	115.0	
Minimum Circuit Ampacity		13.6	18.0	10.5	15.9	19.7	30.4	
Branch Circuit Fuse Size (amps)		20	25	15	20	30	45	
Resistance (ohms)		4.3 S / 0.7 R	3.2 S / 0.4 R	1.8	1.3	1.0	0.7	
Nominal Voltage		208-230/1/60			460/3/60			
Min. - Max. Voltage		187 - 253			414 - 506			
Input Power @ Rated Flow (watts)		932	1280	1255	1962	2910	4120	
Rated Load Amps**		5.4	6.5	3.6	4.7	7.1	9.6	
Locked Rotor Amps**		30.0	35.0	25.0	33.0	44.0	63.0	
Minimum Circuit Ampacity		7.3	9.1	5.2	7.5	10.4	15.2	
Branch Circuit Fuse Size (amps)		15	15	15	15	15	20	
Resistance (ohms) Main/Start		9.0 S / 2.3 R	7.9 S / 1.6 R	7.4	5.0	4.0	2.7	
Nominal Voltage		240/1/50			575/3/60			
Min. - Max. Voltage		216 - 264			518 - 633			
Input Power @ Rated Flow (watts)		680	1019	1255	1962	2910	4120	
Rated Load Amps**		4.5	5.0	3.6	4.7	7.1	9.6	
Locked Rotor Amps**		21.0	30.0	25.0	33.0	44.0	63.0	
Minimum Circuit Ampacity		6.2	7.3	4.2	6.0	8.3	12.2	
Branch Circuit Fuse Size (amps)		15	15	15	15	15	20	
Resistance (ohms)		19.5 S / 3.3 R	10.5 S / 1.8 R	7.4	5.0	4.0	2.7	
Nominal Voltage		N/A			380-420/3/50			
Min. - Max. Voltage		N/A			342 - 462			
Input Power @ Rated Flow (watts)		N/A		1002	1613	2040	2860	
Rated Load Amps**		N/A		3.6	4.7	7.1	9.6	
Locked Rotor Amps**		N/A		25.0	33.0	44.0	63.0	
Minimum Circuit Ampacity		N/A		5.2	7.5	10.4	15.2	
Branch Circuit Fuse Size (amps)		N/A		15	15	15	20	
Resistance (ohms)		N/A		7.4	5.0	4.0	2.7	

* For 60 Hz, 35°F Evaporator, 100°F Ambient; for 50Hz, 35°F Evaporator, 77°F Ambient

** Compressor Only

6.0 DIMENSIONS / WEIGHTS

Dimensions, inches (mm)						
Model	DHP130	DHP200	DHP300	DHP500	DHP750	DHP1000
A	37.56 (954)	37.56 (954)	38.60 (980)	38.60 (980)	58.06 (1475)	58.06 (1475)
B	25.62 (651)	25.62 (651)	32.15 (817)	32.15 (817)	32.15 (817)	32.15 (817)
C	2.50 (63.5)	2.50 (63.5)	2.50 (63.5)	2.50 (63.5)	2.50 (63.5)	2.50 (63.5)
D	23.62 (600)	23.62 (600)	30.15 (766)	30.15 (766)	30.15 (766)	30.15 (766)
E	17.62 (448)	17.62 (448)	30.15 (766)	30.15 (766)	39.62 (1006)	39.62 (1006)
F	19.62 (498)	19.62 (498)	32.15 (817)	32.15 (817)	41.62 (1057)	41.62 (1057)
G	9.58 (243)	9.58 (243)	7.64 (194)	7.64 (194)	20.44 (519)	20.44 (519)
H	14.96 (380)	14.96 (380)	15.80 (401)	15.80 (401)	27.79 (706)	27.79 (706)
I	28.54 (725)	28.54 (725)	30.19 (767)	30.19 (767)	49.06 (1246)	49.06 (1246)
J	25.02 (636)	25.02 (636)	26.04 (661)	26.04 (661)	44.78 (1137)	44.78 (1137)
K	0.31 (7.9)	0.31 (7.9)	0.31 (7.9)	0.31 (7.9)	0.63 (16)	0.63 (16)
L	1.5 MPT	1.5 MPT	1.5 MPT	1.5 MPT	1.5 MPT	1.5 MPT
M	N/A	N/A	4.56 (116)	4.56 (116)	4.81 (122)	4.81 (122)
N	N/A	N/A	9.84 (250)	9.84 (250)	20.82 (529)	20.82 (529)
O	N/A	N/A	3.13 (80)	3.13 (80)	3.13 (80)	3.13 (80)
Weight, lbs (kg)	251 (114)	279 (127)	425 (193)	463 (210)	691 (313)	734 (333)

NOTE: Dimensions and Weights are for reference only. Request certified drawings for construction purposes.

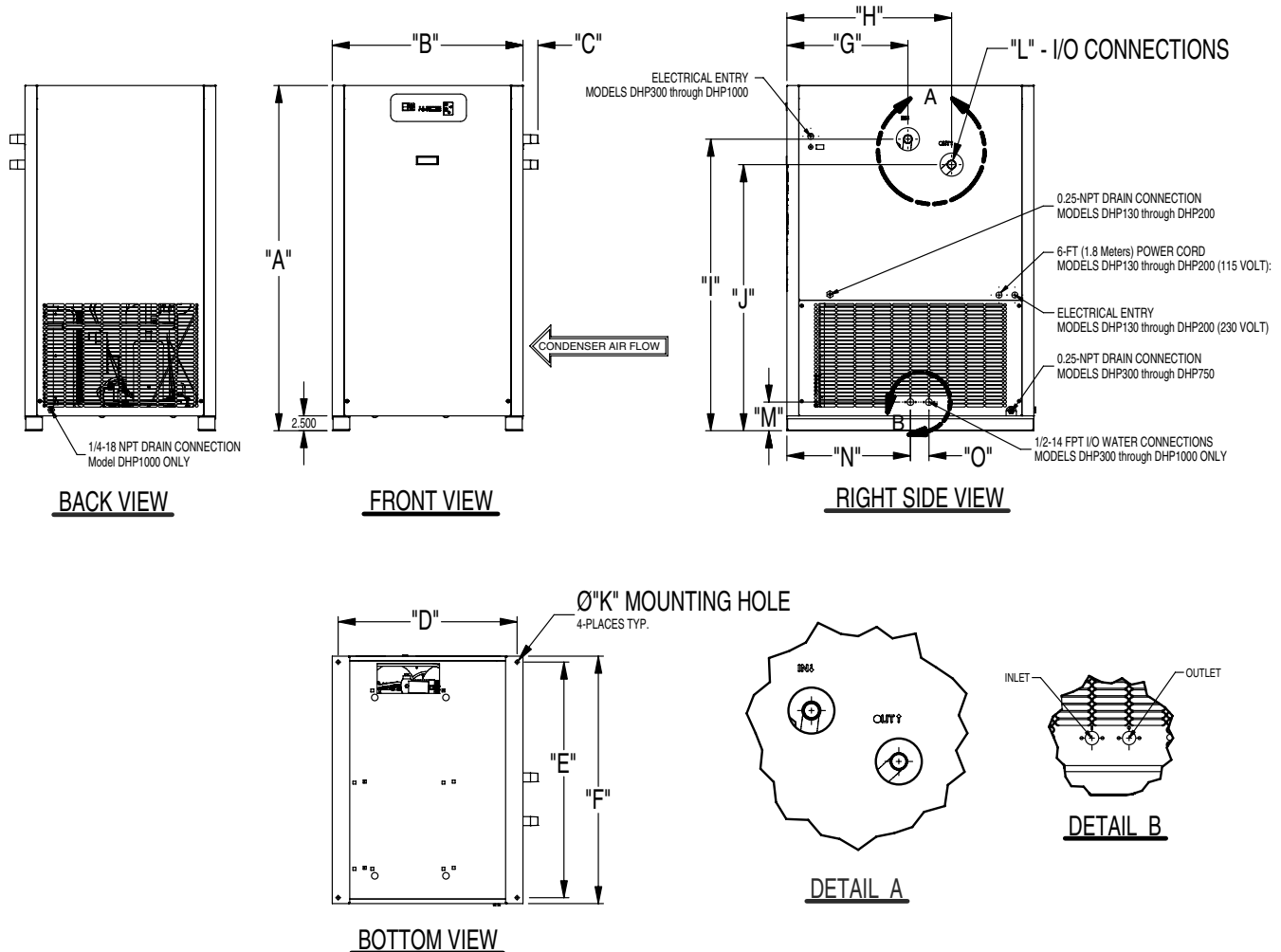

7.0 DRAWINGS

7.1 Process Gas / Refrigeration Flow Diagram: Models DHP130 and DHP200

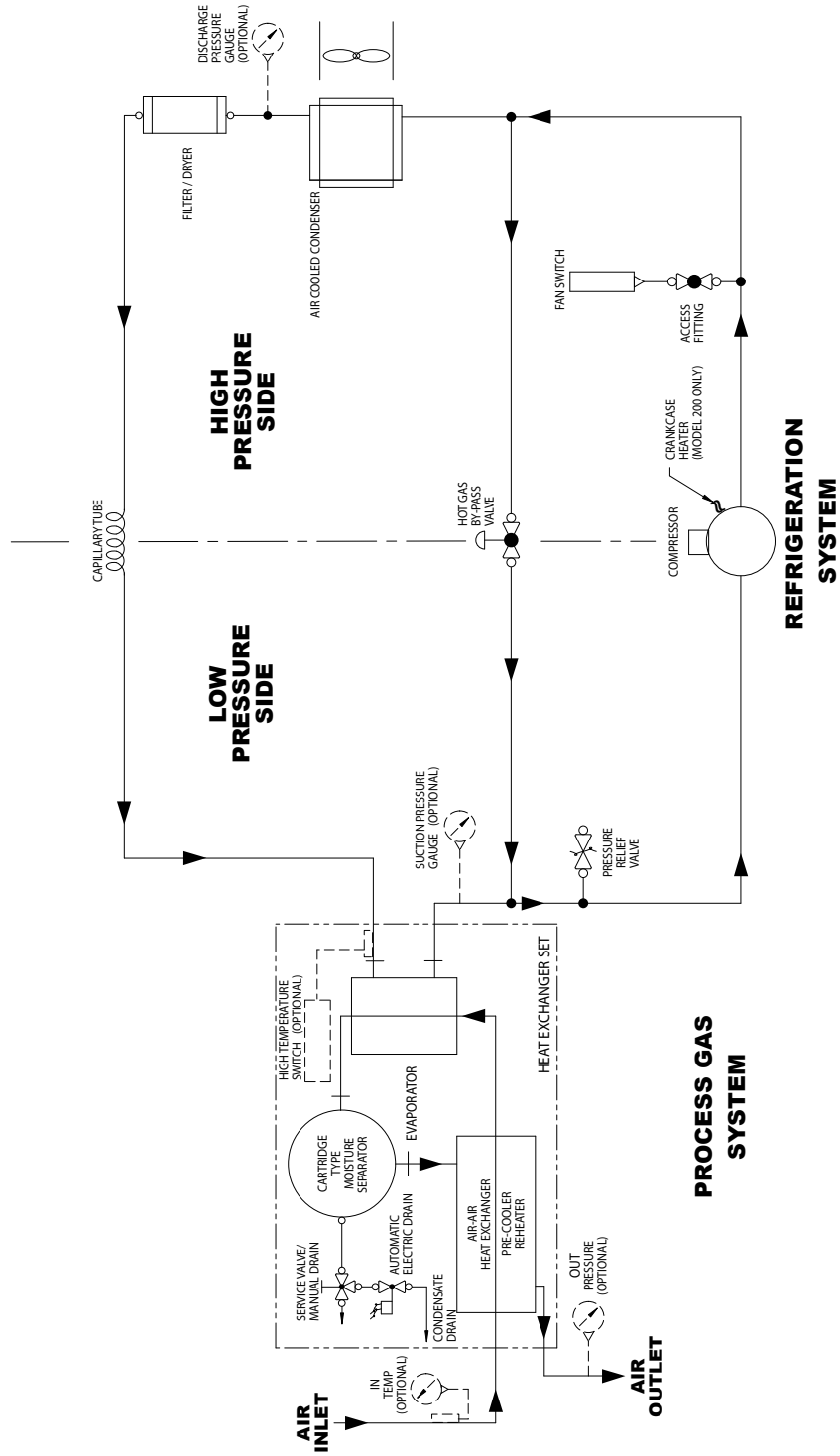

7.2 Process Gas / Refrigeration Flow Diagram: Models DHP300 through DHP1000

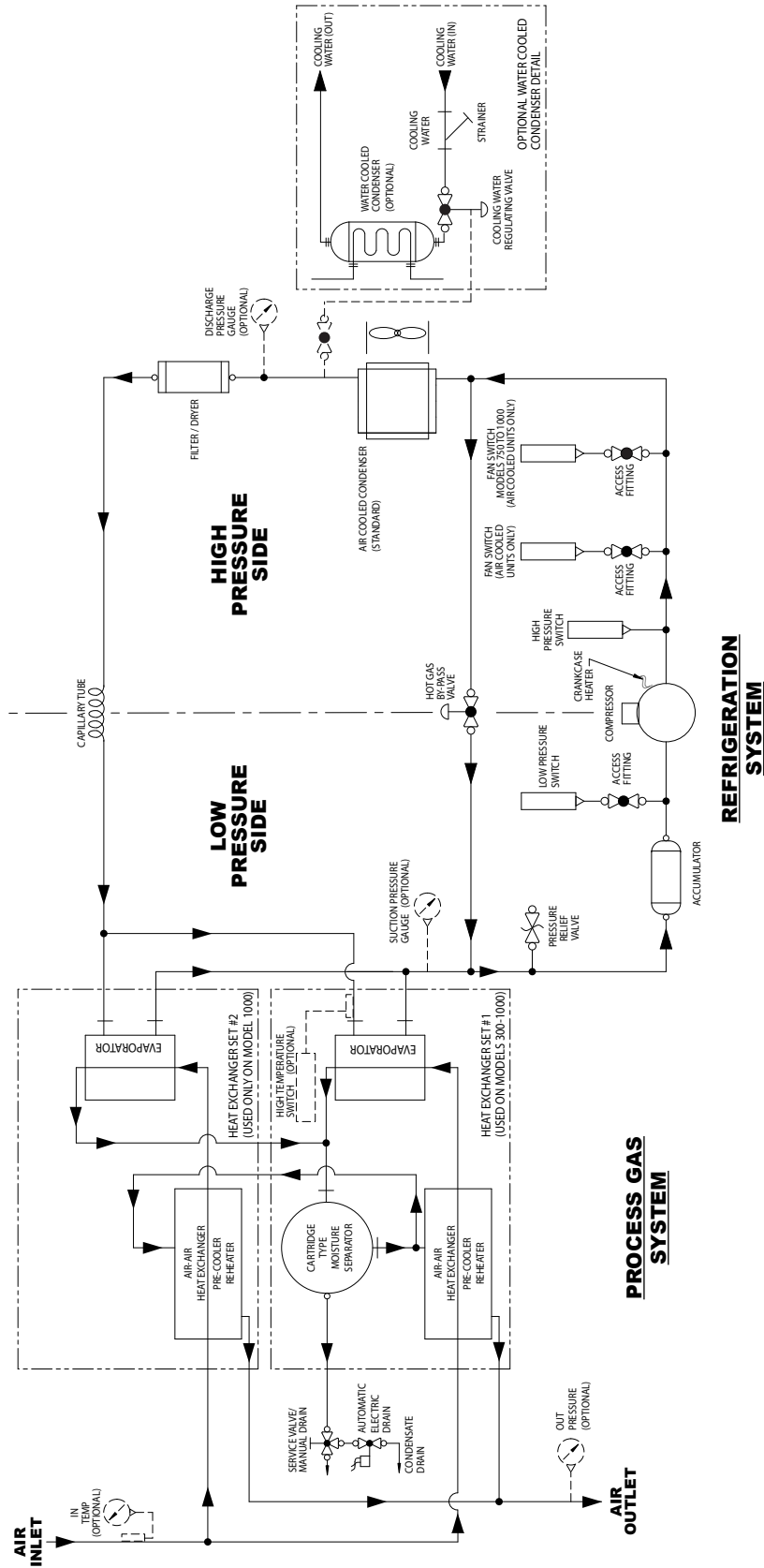

7.3 Wiring Diagram: Models DHP130 and DHP200 (115 or 208-230V/60 Hz, 100 or 240V/50 Hz)

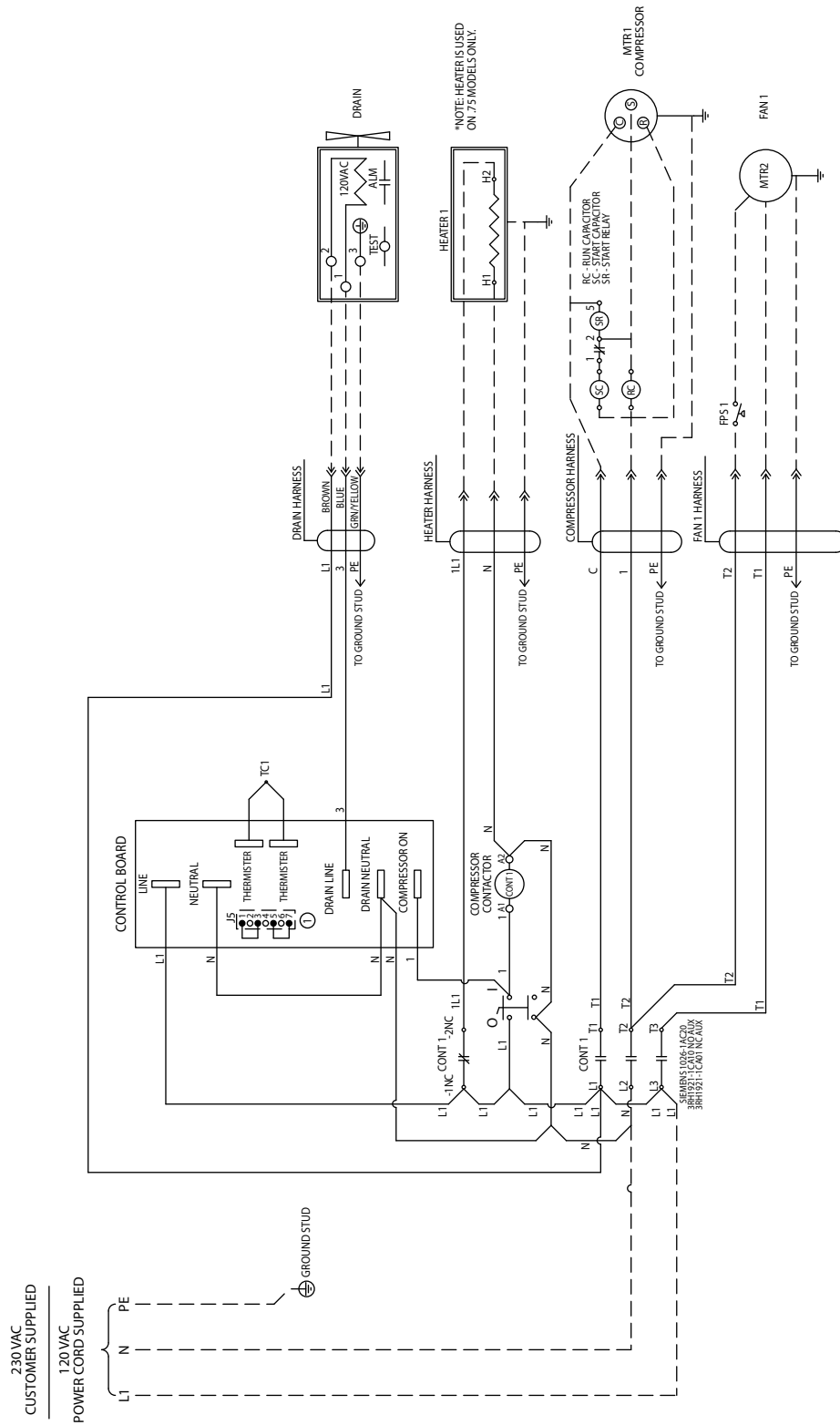

7.4 Wiring Diagram: Models DHP300 through DHP750 (230-400-460V/3/50-60 Hz)

(Page 1 of 2)

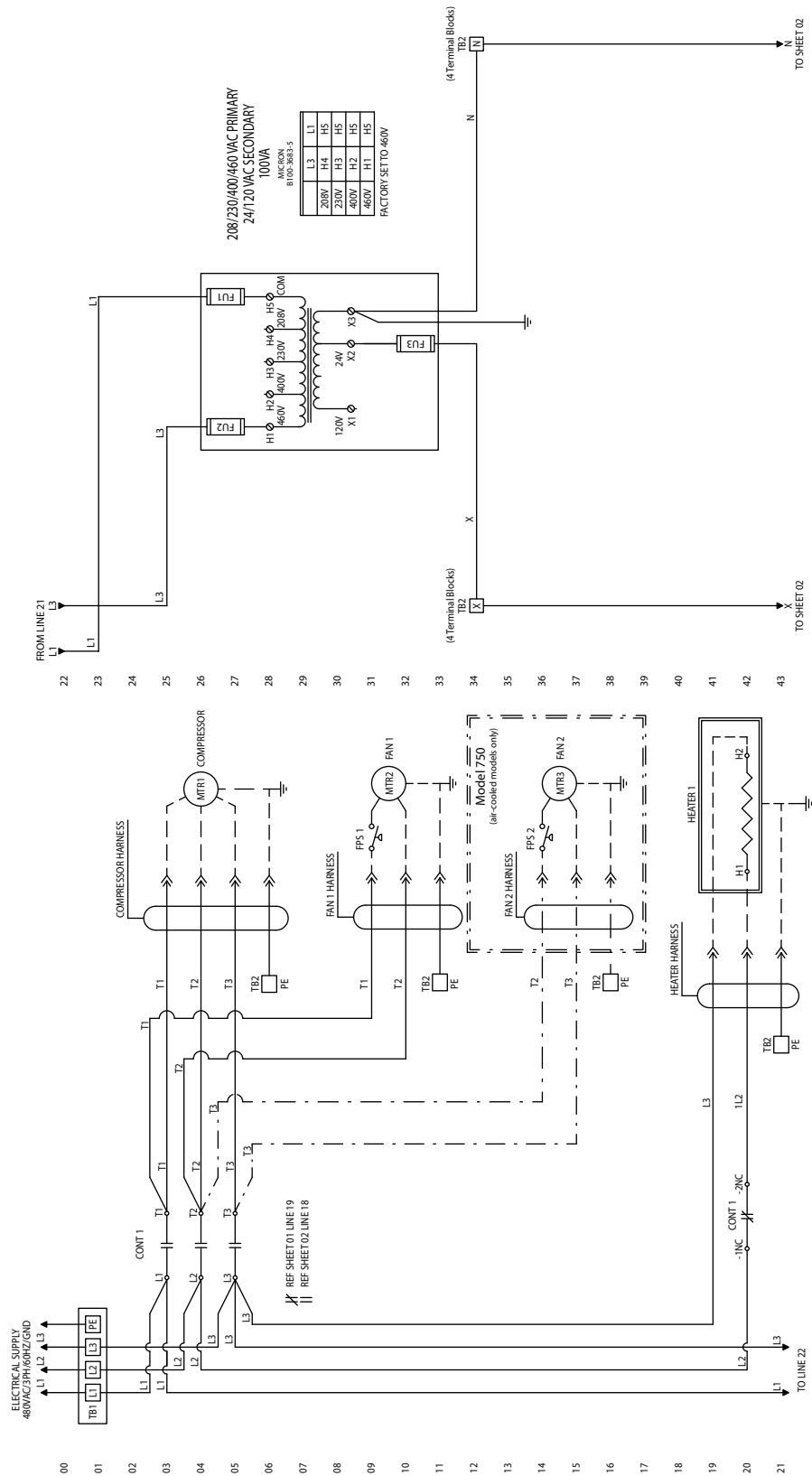

Wiring Diagram: Models DHP300 through DHP750 (230-400-460V/3/50-60 Hz)

(Page 2 of 2)

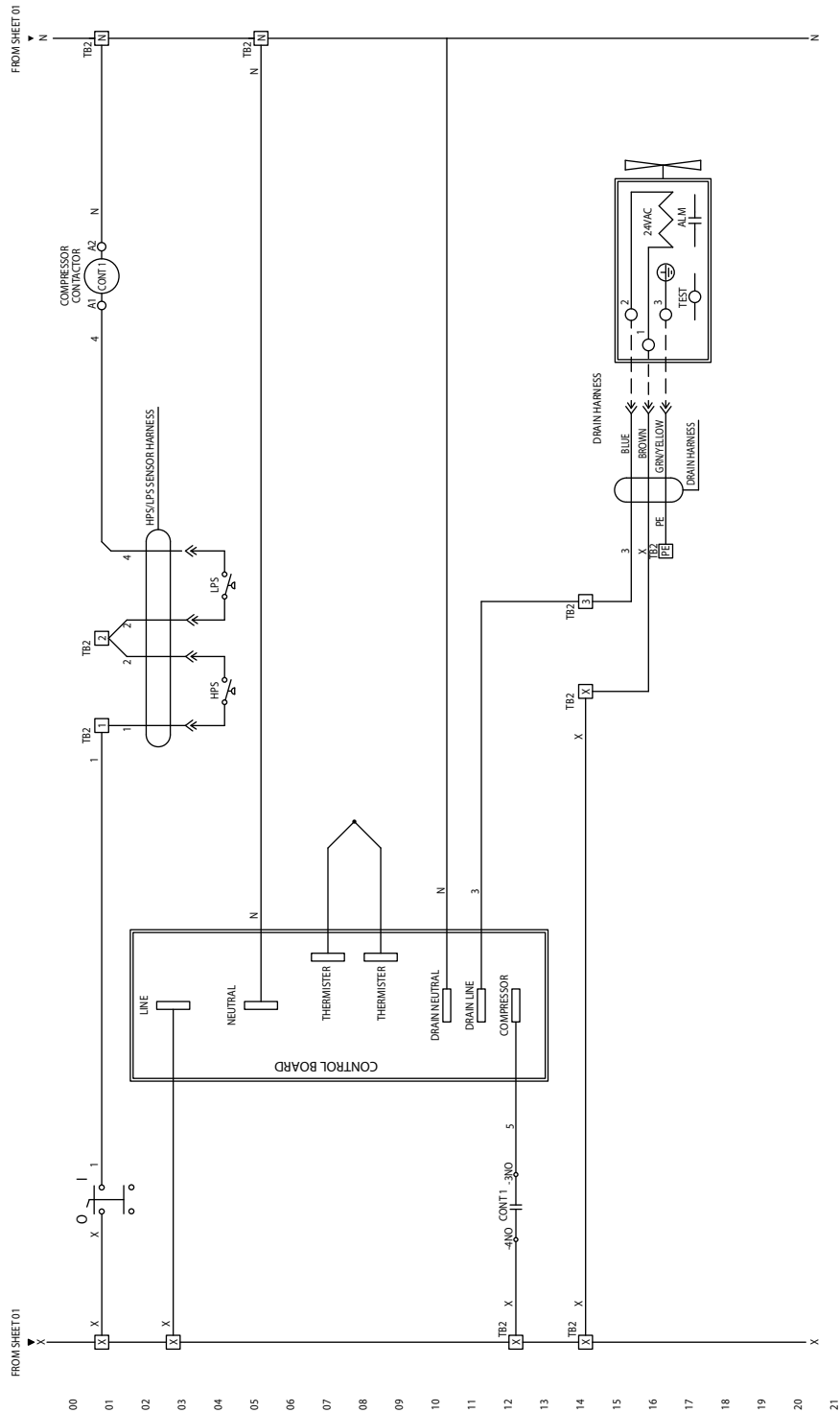

7.5 Wiring Diagram: Model DHP1000 (230-400-460V/3/50-60 Hz)

(Page 1 of 2)

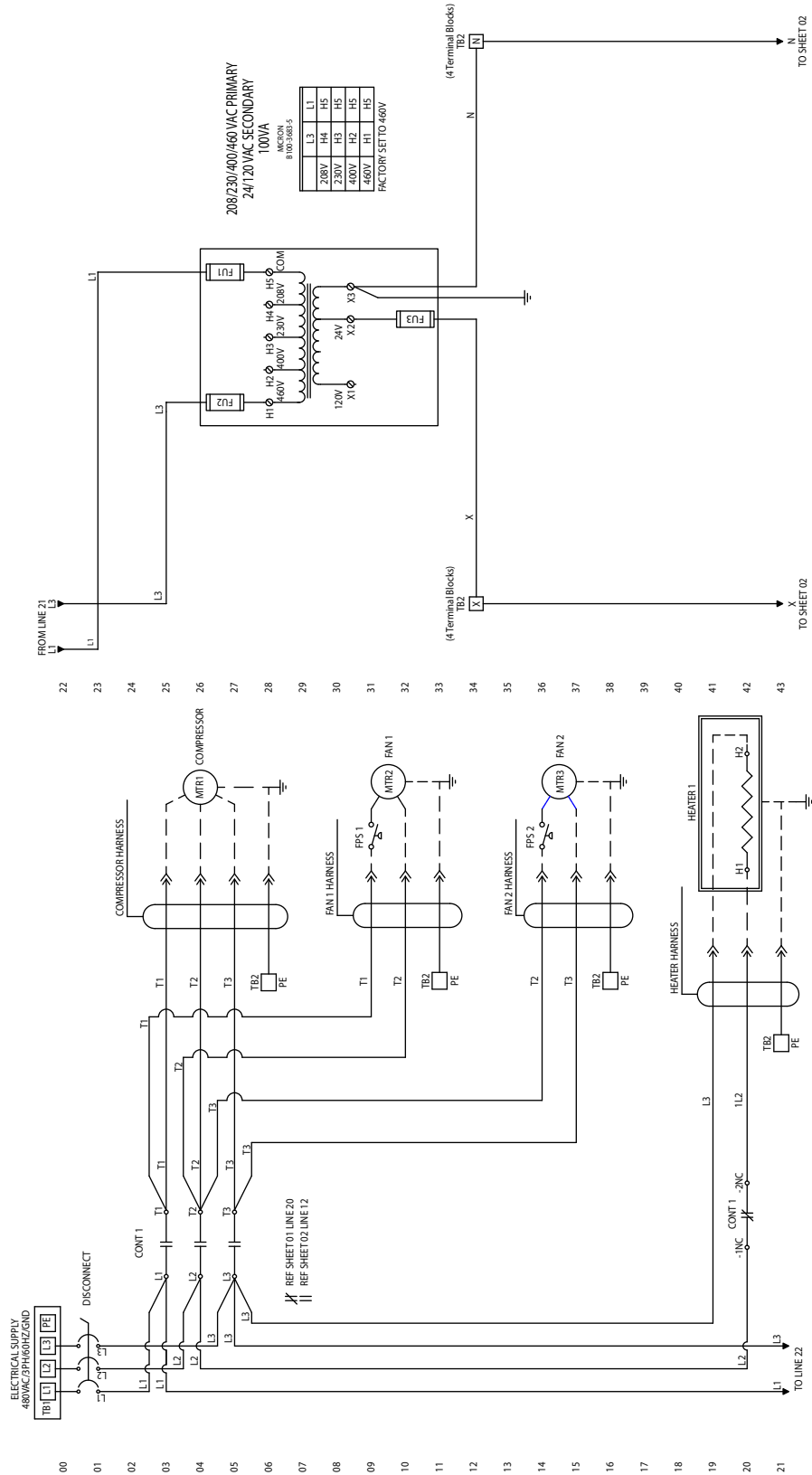

Wiring Diagram: Model DHP1000 (230-400-460V/3/50-60 Hz)

(Page 2 of 2)

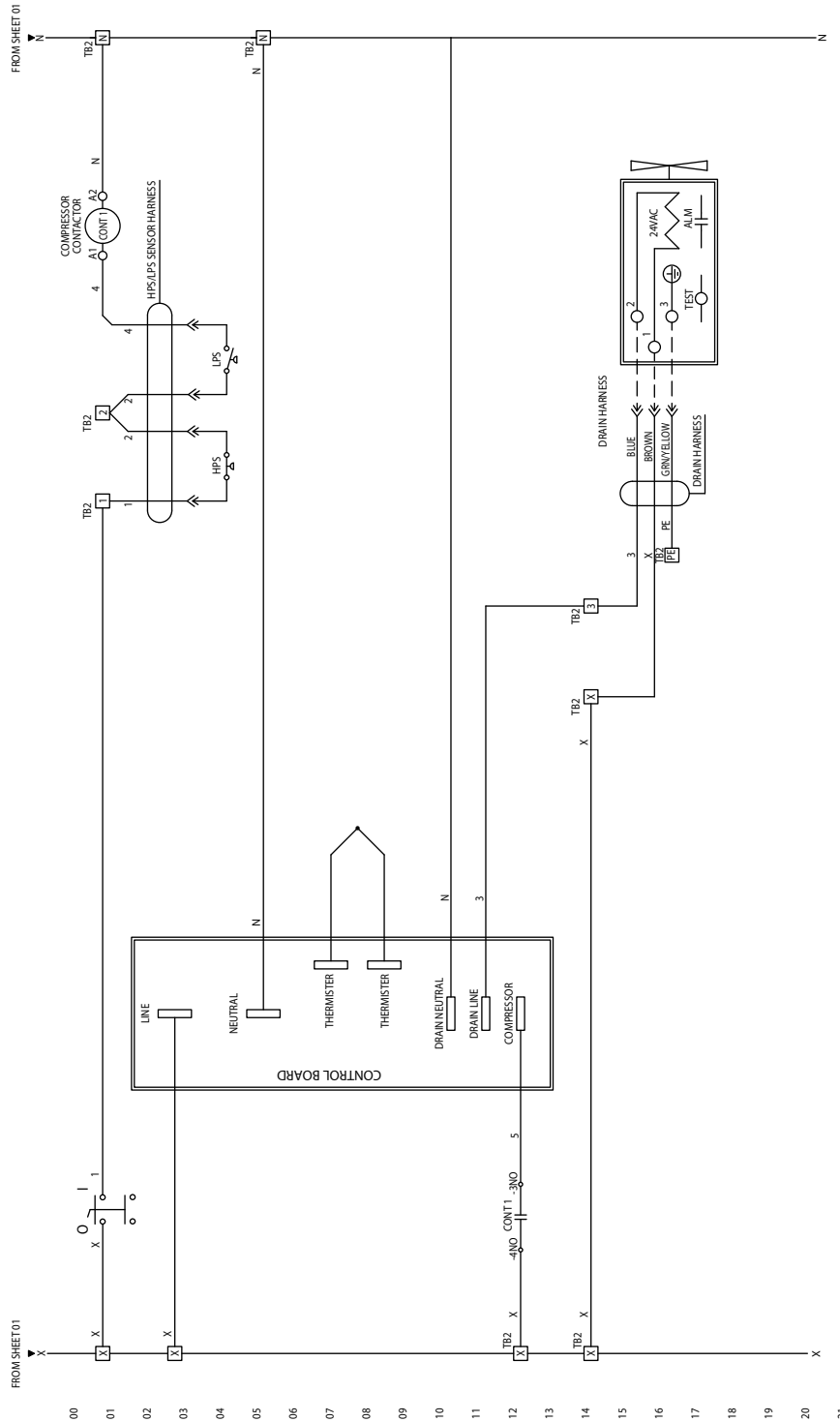

7.6 Wiring Diagram: Models DHP300 through DHP1000 (575-460/3/60 Transformer Pack)

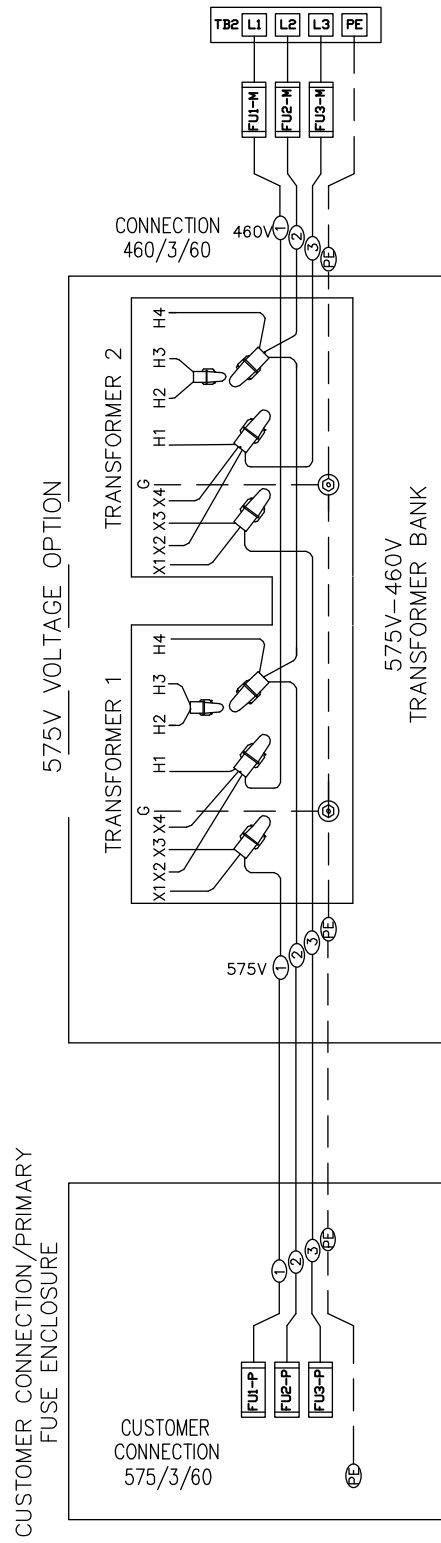

8.0 REPLACEMENT PARTS LIST

8.1 Replacement Parts

PARTS DESCRIPTION	DHP130			DHP200		
	115/1/60 100/1/60	208-230/1/60	220-240/1/50	115/1/60 100/1/60	208-230/1/60	220-240/1/50
Condensing Unit Assembly	5002001	5002002	5002003	7427771	7427772	7427773
Compressor (Only)	5002243	5002250	5002256	7427777	7427778	7427779
Overload	5002244	5002251	5002257	3233219	3233220	3252935
Start Relay	5002245	5002252	5002258	7427780	7427781	7427782
Start Capacitor	5002246	5002253	5002253	7427783	7427784	7427784
Run Capacitor	N/A	N/A	N/A	7427785	7427786	7427787
Fan Motor	5002247	3068667	5002259	3233151	3210368	3210368
Fan Blade	5002248	3090153	3090153	3219405	3219405	3219405
Hot Gas Bypass Valve	5002350	5002350	5002350	5002350	5002350	5002350
Condenser (Air-Cooled)	5002249	5002249	5002249	3232828	3232828	3232828
Dryer	3223808	3223808	3223808	3223809	3223809	3223809
Fan Pressure Switch	3230761	3230761	3230761	3230761	3230761	3230761
Contactora	5002260	5002262	5002262	5002260	5002262	5002262
Auxiliary Contactor	3221413	3211152	3211152	3221413	3211152	3211152
Crankcase Heater	N/A	N/A	N/A	3223258	3223259	3223259
On-Off Switch	3230777	3230777	3230777	3230777	3230777	3230777
Temperature Sensor	3210927N	3210927N	3210927N	3210927N	3210927N	3210927N
Digital PC Board	3227171	3227171	3227171	3227171	3227171	3227171
Digital PC Board Fuse	5002932	5002932	5002932	5002932	5002932	5002932

PARTS DESCRIPTION	208-230/3/60				380-420/3/50, 460/3/60, and 575/3/60			
	DHP300	DHP500	DHP750	DHP1000	DHP300	DHP500	DHP750	DHP1000
Condensing Unit Assembly	5002007	5002009	5002013	5002015	5002008	5002010	5002014	5002016
Compressor (Only)	3221303	3232809	5002921	7428008	3210937	3211540	5002930	7428007
Fan Motor	3118700	3233153	5002922	3233153	3233152	3228005	5002931	3228005
Fan Blade	3232640	3232642	5002923	3219406	3232640	3232642	5002923	3219406
Crankcase Heater	3232974	3232974	3223261	3223261	3232975	3232975	3223260	3223260
Condenser (Air-Cooled)	3232829	3232830	5002924	3232832	3232829	3232830	5002924	3232832
Low Refrigerant Pressure Switch	4006372	4006372	4006372	4006372	4006372	4006372	4006372	4006372
High Refrigerant Pressure Switch	3230764	3230764	3230764	3230764	3230764	3230764	3230764	3230764
Fan Cutout Switch 1	3230762	3230762	3230762	3230762	3230762	3230762	3230762	3230762
Fan Cutout Switch 2	N/A	N/A	3230763	3230763	N/A	N/A	3230763	3230763
Hot Gas By-Pass Valve (Air-Cooled)	5002350	5002350	5002351	5002351	5002350	5002350	5002351	5002351
Filter Dryer (Liquid Line)	5002925	5002925	5002925	5002925	5002925	5002925	5002925	5002925
Temperature Sensor	3210927N	3210927N	3210927N	3210927N	3210927N	3210927N	3210927N	3210927N
Contactora	7419137	7419137	7419137	5002928	7419137	7419137	7419137	5002928
Auxiliary Contactor	7419138	7419138	7419138	7419138	7419138	7419138	7419138	7419138
Transformer 230/400/460	3230893	3230893	3230893	3230893	3230893	3230893	3230893	3230893
Fuse Primary	3223962	3223962	3223962	3223962	3223953	3223953	3223953	3223953
Fuse Secondary	1228769	1228769	1228769	1228769	1228769	1228769	1228769	1228769
Digital PC Board	3227172	3227172	3227172	3227172	3227172	3227172	3227172	3227172
Digital PC Board Fuse	5002932	5002932	5002932	5002932	5002932	5002932	5002932	5002932
Power Transformer (575V)	3073856	3073856	3073856	3073856	3073856	3073856	3073856	3073856
Refrigerant High Pressure Switch (H ₂ O)	3230764	3230764	3230764	3230764	3230764	3230764	3230764	3230764
On-Off Switch	3230777	3230777	3230777	3230777	3230777	3230777	3230777	3230777
Cooling Water Regulatory Valve	3232502	3232502	3232503	3232503	3232502	3232502	3232503	3232503
Cooling Water Strainer Screen	3230672	3230672	3230672	3230672	3230672	3230672	3230672	3230672

8.2 Maintenance Kits

MODEL	DHP130	DHP200	DHP300	DHP500	DHP750	DHP1000
Standard Kit *	HPDMK8	HPDMK8	HPDMK9	HPDMK9	HPDMK9	HPDMK9
Standard Kit **	HPDMK8A	HPDMK8A	HPDMK9A	HPDMK9A	HPDMK9A	HPDMK9A

* = Kit to be used for dryers manufactured after June 2010

** = Kit to be used for dryers manufactured before June 2010

Phone: 724-745-8647
 FAX: 724-745-4967
 Email: deltech.americas.am@spxflow.com
 Web: www.spxflow.com/deltech

NOTES

WARRANTY

The manufacturer warrants the product manufactured by it, when properly installed, operated, applied, and maintained in accordance with procedures and recommendations outlined in manufacturer's instruction manuals, to be free from defects in material or workmanship for a period as specified below, provided such defect is discovered and brought to the manufacturer's attention within the aforesaid warranty period.

The manufacturer will repair or replace any product or part determined to be defective by the manufacturer within the warranty period, provided such defect occurred in normal service and not as a result of misuse, abuse, neglect or accident. Normal maintenance items requiring routine replacement are not warranted. The warranty covers parts and labor for the warranty period unless otherwise specified. Repair or replacement shall be made at the factory or the installation site, at the sole option of the manufacturer. Any service performed on the product by anyone other than the manufacturer must first be authorized by the manufacturer.

Unauthorized service voids the warranty and any resulting charge or subsequent claim will not be paid. Products repaired or replaced under warranty shall be warranted for the unexpired portion of the warranty applying to the original product.

The foregoing is the exclusive remedy of any buyer of the manufacturer's product. The maximum damages liability of the manufacturer is the original purchase price of the product or part.

THE FOREGOING WARRANTY IS EXCLUSIVE AND IN LIEU OF ALL OTHER WARRANTIES, WHETHER WRITTEN, ORAL, OR STATUTORY, AND IS EXPRESSLY IN LIEU OF THE IMPLIED WARRANTY OF MERCHANTABILITY AND THE IMPLIED WARRANTY OF FITNESS FOR A PARTICULAR PURPOSE. THE MANUFACTURER SHALL NOT BE LIABLE FOR LOSS OR DAMAGE BY REASON OF STRICT LIABILITY IN TORT OR ITS NEGLIGENCE IN WHATEVER MANNER INCLUDING DESIGN, MANUFACTURE OR INSPECTION OF THE EQUIPMENT OR ITS FAILURE TO DISCOVER, REPORT, REPAIR, OR MODIFY LATENT DEFECTS INHERENT THEREIN.

THE MANUFACTURER, HIS REPRESENTATIVE OR DISTRIBUTOR SHALL NOT BE LIABLE FOR LOSS OF USE OF THE PRODUCT OR OTHER INCIDENTAL OR CONSEQUENTIAL COSTS, EXPENSES, OR DAMAGES INCURRED BY THE BUYER, WHETHER ARISING FROM BREACH OF WARRANTY, NEGLIGENCE OR STRICT LIABILITY IN TORT.

The manufacturer does not warrant any product, part, material, component, or accessory manufactured by others and sold or supplied in connection with the sale of manufacturer's products.

Warranty Period

Parts and labor for two (2) years from the date of shipment from the factory; heat exchangers are covered (parts only) for an additional three (3) years (total of five [5]). On units that manufacturer requests be returned to the factory, a one time removal/reinstallation labor allowance as noted in the Service Warranty Policies and Procedures Handbook will apply. Freight to the factory from the installation site and to the installation site from the factory will be paid by the manufacturer; means of transportation to be specified by manufacturer.

AUTHORIZATION FROM THE SERVICE DEPARTMENT IS NECESSARY BEFORE MATERIAL IS RETURNED TO THE FACTORY OR IN-WARRANTY REPAIRS ARE MADE.

SERVICE DEPARTMENT: (724) 746-1100

SPXFLOW[®]

DHP SERIES

High Pressure Refrigerated Type
Compressed Air Dryer

Models: DHP130, DHP200, DHP300,
DHP500, DHP750, DHP1000

SPX FLOW

4647 S.W. 40th Avenue

Ocala, Florida 34474-5788 U.S.A.

P: (724) 745-8647

F: (724) 745-4967

E: deltech.americas@spxflow.com

www.spxflow.com/deltech

Improvements and research are continuous at SPX FLOW, Inc.

Specifications may change without notice.

ISSUED 07/2016 Form No.: 5003971 Revision: F

COPYRIGHT ©2016 SPX FLOW, Inc.