

DSHD Series

Desiccant Compressed Air Dryer

Models: DSHD-7, DSHD-13, DSHD-18, DSHD-21, DSHD-27, DSHD-40

FORM NO.: 7443488 REVISION: 10/2020

READ AND UNDERSTAND THIS MANUAL PRIOR TO OPERATING OR SERVICING THIS PRODUCT.



Contents

1.0	General Safety Information	1
2.0	Receiving, Storing, and Moving	1
2.1	Receiving and Inspection	1
2.2	Storing	1
2.3	Handling	1
3.0	Description	2
3.1	Function	2
3.2	Operation	2
4.0	Installation and Mounting	3
4.1	Location of Installation	3
4.2	Service Clearance	3
4.3	Mounting	3
4.4	Connection to the Compressed Air System	3
4.5	Connection to the Dryer	3
4.6	Pre- and After- Filter	3
4.7	Piping	3
4.8	Electrical Connection	3
4.8.1	Potential Free Contacts	3
4.8.2	Network Connection	4
4.9	Ambient Conditions	4
5.0	Initial Start-Up (Start up after prolonged inoperative periods)	5
5.1	Preconditions	5
5.2	Switching ON the Dryer	5
5.3	Operation	5
5.4	Switching OFF the Dryer	5
6.0	Operation (Switching on, Switching off, Controls)	5
6.1	Preconditions for Operation	5
6.2	Switching ON the Dryer	5
6.3	Operation	5
6.4	Switching OFF the Dryer	5
6.5	Controls (Panel)	6
6.5.1	Start Screen	7
6.5.2	Message History	7
6.5.3	Remote On/Off Settings	8
6.5.4	Setting Menu	8
6.6	Purge Air Consumption	10
6.6.1	Maximum Purge Flow	10
6.6.2	Average Purge Flow	10
6.6.3	Minimum Outlet Flow	10
6.6.4	Timer Board Settings & Remote Control	10
7.0	Servicing and Maintenance	11
7.1	Nameplate	11
7.2	Ordering Consumable Parts and Operating Materials	11
7.3	Weekly Maintenance	11
7.4	Annual Maintenance	11
7.5	Depressurize the Desiccant Dryer	11
7.6	Replacement of Desiccant	11
7.6.1	Replacement of Purge Solenoid Valves	11
7.7	Prefilter/Afterfilter Maintenance	12
8.0	Troubleshooting Guide	13
9.0	Technical Data	15
9.1	Maximum Purge Flow	15
9.2	Ambient Temperature	15
9.3	Electrical Data	15
9.4	Desiccant	16
9.5	Condensate	16
9.6	Measurements, Weights	16
9.7	Nominal Air Flow	16
9.8	Correction Factors	16
10.0	Replacement Parts & Maintenance Kits	17
10.1	Replacement Parts	
10.2	Maintenance Kits	
11.0	Drawings	18
11.1	General Arrangement: DSHD-7	18
11.2	General Arrangement: DSHD-13	19
11.3	General Arrangement: DSHD-18	20
11.4	General Arrangement: DSHD-21	21
11.5	General Arrangement: DSHD-27	22
11.6	General Arrangement: DSHD-40	23
11.7	P&I Diagram	24
11.8	Electrical Schematic	26
11.9	Electrical Schematic With Electronic Drain Option	27
Warranty		29

1.0 General Safety Information

This equipment is designed and built with safety as a prime consideration; industry-accepted safety factors have been used in the design. Each dryer is checked at the factory for safety and operation. All pressure vessels which fall under the scope of ASME Section VIII, are hydrostatically tested in accordance with the latest addenda.

WARNING – The following safety rules must be observed to ensure safe dryer operation. Failure to follow these rules may void the warranty or result in dryer damage or personal injury.

1. Never install or try to repair any dryer that has been damaged in shipment. See the Receiving and Inspection instructions in this manual for appropriate action.
2. This equipment is a pressure-containing device. Never operate the dryer at pressures or temperatures above the maximum conditions shown on the data plate.

Never dismantle or work on any component of the dryer or compressed air system under pressure. Vent internal air pressure to the atmosphere before servicing.
3. This equipment requires electricity to operate. Install equipment in compliance with national and local electrical codes. Standard equipment is not intended for installation in hazardous environments.

Never perform electrical service on the dryer unless the main power supply has been disconnected. Parts of the control circuit may remain energized when the power switch is turned off.
4. Air treated by this equipment may not be suitable for breathing without further purification. Refer to OSHA standard 1910.134 for the requirements for breathing quality air.
5. Use only genuine replacement parts from the manufacturer. The manufacturer bears no responsibility for hazards caused by the use of unauthorized parts.

Safety instructions in this manual are boldfaced for emphasis. The signal words **DANGER**, **WARNING** and **CAUTION** are used to indicate hazard seriousness levels as follows:

DANGER – Immediate hazard which will result in severe injury or death.

WARNING – Hazard or unsafe practice which could result in severe injury or death.

CAUTION – Hazard or unsafe practice which could result in minor injury or in product or property damage.

The dryer data plate contains critical safety and identification information. If the data plate is missing or defaced, immediately contact your local distributor for a replacement.

2.0 Receiving, Storing, and Moving

2.1 Receiving and Inspection

This shipment has been thoroughly checked, packed and inspected before leaving our plant. It was received in good condition by the carrier and was so acknowledged.

Immediately upon receipt, thoroughly inspect for visible loss or damage that may have occurred during shipping. If this shipment shows evidence of loss or damage at time of delivery to you, insist that a notation of this loss or damage be made on the delivery receipt by the carrier's agent. Otherwise no claim can be enforced against the carrier.

Also check for concealed loss or damage. When a shipment has been delivered to you in apparent good order, but concealed damage is found upon unpacking, notify the carrier immediately and insist on his agent inspecting the shipment. The carrier will not consider any claim for loss or damage unless an inspection has been made. If you give the carrier a clear receipt for goods that have been damaged or lost in transit, you do so at your own risk and expense. Concealed damage claims are not our responsibility as our terms are F.O.B. point of shipment. Shipping damage is not covered by the dryer warranty.

2.2 Storing

Store the dryer indoors to prevent damage to any electrical or mechanical components. All packaging material should be left in place until the dryer is in position.

The storage temperature should be between 32°F (0°C) and 131°F (55°C). Frost or higher temperature can cause damage.

Contact the manufacturer for long term storage/commissioning periods greater than 6 months.

2.3 Handling

CAUTION – Never lift the dryer by attaching hooks or slings to the compressed air inlet or air outlet connections. Severe structural damage could occur.

IMPORTANT: Allow handling only by personnel trained in the safe movement of loads.

3.0 Description

3.1 Function

Dual tower regenerative desiccant dryers are utilized to dry compressed air to dew points below the freezing point of water or reduce the moisture content to low levels for use in critical process applications.

Air is dried by using two identical towers, each containing a desiccant bed. While one tower is on-stream drying the compressed air, the other tower is off-stream being regenerated (reactivated, i.e., dried out).

Desiccant dryers lower the dew point by adsorbing most of the water vapor present onto the surface of the desiccant. Adsorption occurs until an equilibrium is reached between the partial pressure of the water vapor in the air and that on the surface of the desiccant.

Desiccant can then be regenerated by desorbing the water collected on its surface. Regeneration occurs by expanding a portion of the dried air to atmospheric pressure. This very dry air (called purge air) causes the moisture to desorb from the desiccant and then carries the desorbed water out of the dryer.

3.2 Operation

The Drying Circuit: Up-Flow Drying

- A. The incoming compressed air travels through the oil removal pre-filter (1) and enters the top manifold assembly (2).
- B. A shuttle valve and flow distributor direct the airflow downward through a transfer tube (3) to the bottom manifold assembly (4).
- C. The dried compressed air moves through a flow distributor to the dryer outlet (6).
- D. The air travels through particle removal after-filter (7). The clean, dry air is now ready use.
 - 1) In the Class 2 fixed mode (-40°F pdp), the on-line cartridge dries the air for a period of 4 minutes.
 - 2) In the Class 1 pdp mode (-94°F pdp), the on-line cartridge dries the air for a period of 2 minutes.

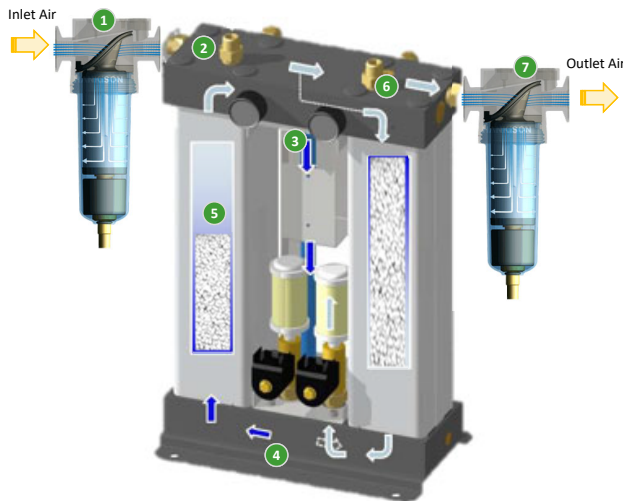

Example above: Left tower drying / Right tower regenerating

Up-Flow Drying

The Regeneration Circuit: Down-Flow Regeneration

- A. A portion of the ultra-dry air is throttled to near atmospheric pressure through a purge orifice (1) directing the air through the right desiccant cartridge (2). The water vapor is effectively desorbed from the desiccant.
- B. The purge air then passes through flow distributor (3), upward through purge valve (4) and purge air muffler (5), then exhausted to atmosphere.
 - 1) In the Class 2 (-40°F pdp) fixed dew point mode, the dryer regenerates for 3 minutes and 20 seconds. The purge valve then closes, slowing repressuring in the right cartridge for 40 seconds to line pressure. With the right cartridge fully regenerated, it is now prepared to go online & dry the air.
- C. After 40 seconds of repressurization, the left purge valve opens (6) & depressurizes. The offline tower is now ready to go back on-line.
- D. This moves the inlet shuttle valve moves into position. The incoming air now passes through the shuttle valve (via the flow distributor) to the right desiccant cartridge, where it is dried to the desired dew point.
 - 1) In the Class 2 fixed mode, the full cycle time is 8 minutes – 4 minutes drying & 4 minutes regenerating.
 - 2) In the Class 1 fixed mode, the full cycle time is 4 minutes – 2 minutes drying & 2 minutes regenerating.

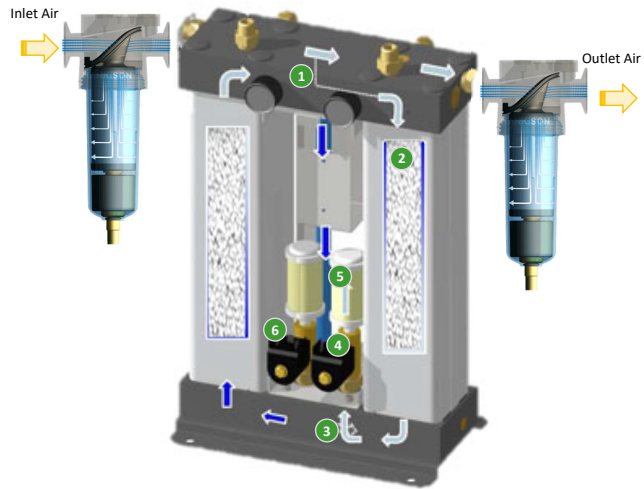

Example above: Left tower drying / Right tower regenerating

Down-Flow Regeneration

4.0 Installation and Mounting

4.1 Location of Installation

The desiccant compressed air dryer should be installed in a dry room indoors. Ample free space should be allowed for the maintenance of the device.

The dryer is furnished in a cabinet for floor mounting.

The dryer is suitable for floor or wall mounting with a bracket (see chapter "General Arrangement drawing") (OPTION).

If supplied, install pre-filter and after-filter, which are packed separately, in the pipe system. Please use the connector adapters.

4.2 Service Clearance

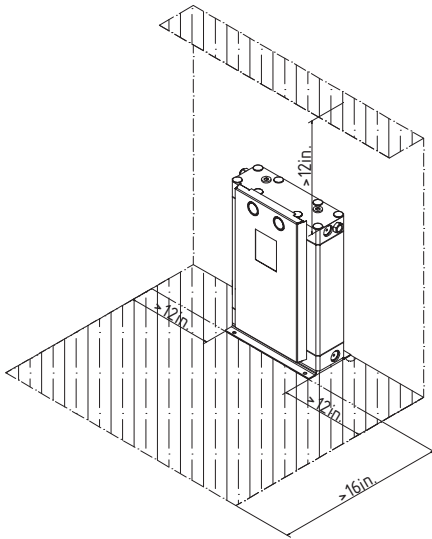

4.3 Mounting

WARNING – When a valve is installed after the dryer an appropriate safety relief valve should be installed to prevent over pressurization of the dryer due to external causes (fire).

CAUTION – When installing the dryer ensure all connections are even and no pressure is placed on inlet and outlet connections.

CAUTION – Check all compressed-air connections to ensure that they are firm and free of leaks.

4.4 Connection to the Compressed Air System

The compressed air inlet and outlet line should be equipped with shut off valves and a bypass system.

When installing a bypass, its function and influence on the compressed air quality, must be known when used.

4.5 Connection to the Dryer

The dryer is shipped complete with desiccant and ready to operate after filtration, compressed air piping, condensate piping and electrical connections are made.

4.6 Pre- and After- Filter

IMPORTANT: In order to ensure correct functioning of the desiccant dryer, an oil removal filter with a max. residual oil of 0.01 ppm must be installed. To protect the down-line system from desiccant dust, a dust filter must be installed.

4.7 Piping

The piping between the preliminary filter and the dryer must be short and corrosion-resistant.

4.8 Electrical Connection

The dryer is equipped with a plug.

Check to see that power supply to dryer is the same as the power requirements indicated on the identification label. Install plug into receptacle of proper voltage or hardwire to pigtailed and ground screw inside cabinet according to electrical drawings in the back of this manual. Be sure to follow all applicable electrical codes.

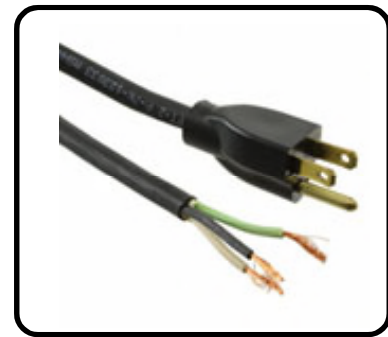

4.8.1 Potential Free Contacts

All externally connected cables (pot. free wiring) should be fixed by means of cable ties as shown in the picture.



4.8.2 Network Connection

The network cable should be provided with a loop, be fixed under the control using cable ties (see picture).



When opening the controller, the network cable must be pushed carefully to avoid mechanical stress on the network socket.



4.9 Ambient Conditions

Locate the dryer under cover in an area where the ambient air temperature will remain between 35°F (2°C) and 120°F (49°C).

NOTE: If dryer is installed in ambients below 35°F (2°C), low ambient protection requiring heat tracing and insulation of the prefilter bowls, and auto drains and/or sumps is necessary to prevent condensate from freezing. If installing heat tracing, observe electrical class code requirements for type of duty specified. Purge mufflers and their relief mechanisms must be kept clear from snow and ice buildup that could prevent proper discharge of compressed air.

5.0 Initial Start-up

(Start up after prolonged inoperative periods)

5.1 Preconditions

The desiccant compressed air-dryer is ready for operation when:

- The device has been installed in accordance with section 4. "Installation".
- All inlet and outlet lines have been correctly connected.
- The required forms of energy (electricity, compressed air) are available.
- A stable power supply must be available.
- The shut-off devices (e.g. butterfly valve, ball valve) in the compressed-air inlet line are opened and in the outlet line are closed (if installed).
- The compressed-air bypass is open (if installed).
- The appropriate operating voltage is supplied to the dryer.
- Filters are mounted.
- Condensate piping mounted.

IMPORTANT: The dryer is preset at the factory, see chapter 6.6.4.

5.2 Switching ON the Dryer

The device is to be switched on only when all the conditions specified in section 5.1 have been fulfilled.

- A. Dryer is under operating pressure.
- B. Press the "I / O" button.
- C. The dryer must be regenerated for approx. 6 hours without compressed-air being supplied to the network.
- D. Open the shut-off device in the compressed-air outlet line (if installed).
- E. Close the compressed-air bypass (if installed).

5.3 Operation

IMPORTANT: Please note the information provided in Chapter 7. "Servicing and Maintenance".

5.4 Switching OFF the Dryer

- A. Press the "I / O" button.
 - Dryer is switched off.

CAUTION – The dryer is still pressurized!
To depressurize see Chapter 7. "Servicing and Maintenance".

6.0 Operation

(Switching on, Switching off, Controls)

6.1 Preconditions for Operation

The dryer is ready for operation when the following conditions have been fulfilled:

- The installation of the dryer in accordance with section 4. "Installation".
- Dryer has been commissioned in accordance with section 5. "Initial Start-Up".
- All inlet and outlet lines have been correctly connected.
- The required forms of energy (electricity, compressed air) are available.
- The compressed-air inlet and outlet line are pressurized.
- Shut-off devices (butterfly valve, ball valve) in the compressed-air inlet and outlet lines are open.
- Bypass (if installed) in the compressed-air line up-line of the desiccant compressed-air dryer is closed.
- The appropriate operating voltage is supplied to the dryer.
- Slowly pressurize the system up to working pressure.

6.2 Switching ON the Dryer

The dryer is to be switched on only when all the requirements specified in section 6.1 "Preconditions" have been fulfilled.

- A. Press the "I / O" button.
 - The dryer is now in operation.

If "remote control" is selected (see Section 6.6.4), the dryer can be stopped via contact REM/GND (see diagram).

No connection means "Remote On".

Or if selected via Modbus:

When remotely controlled via Modbus, the dryer will remain in its state (on / off) if the Modbus connection is disconnected.

6.3 Operation

IMPORTANT: Please note the information provided in Chapter 7. "Servicing and Maintenance".

6.4 Switching OFF the Dryer

- A. Close the shut-off devices in the compressed air line before and after the desiccant dryer to avoid a flow through the dryer when it is switched off. Close the condensate line to the condensate drain to avoid flooding the desiccant dryer with condensate in the event of internal pressure loss.
- B. Press the "I / O" button. (Only possible on local operation. De-energize at remote operation).
 - Dryer is switched off.



CAUTION – The dryer is still pressurized!
To depressurize see Chapter 7. "Servicing and Maintenance".

IMPORTANT: The dryer is designed for continuous operation. After prolonged inoperative periods, the desiccant compressed air dryer is to be restarted as specified in section 5.2 "Switching ON the Dryer".

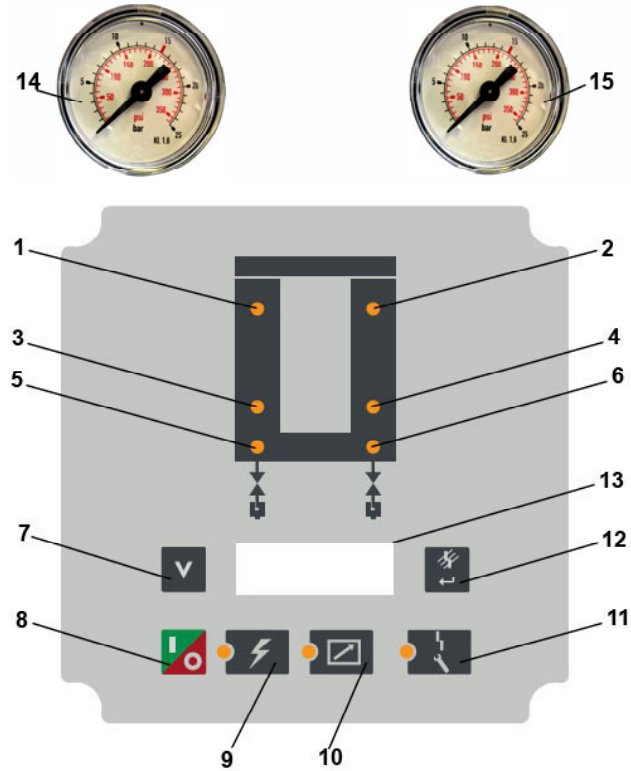
6.5 Controls (Panel)



1. Left cartridge drying LED (green)
2. Right cartridge drying LED (green)
3. Left cartridge regenerating LED (yellow)
4. Right cartridge regenerating LED (yellow)
5. Left purge valve LED (green)
6. Right purge valve LED (green)
7. Mark / Scroll
8. Power On/ Off switch
9. Power On LED
10. LED Remote ON/OFF
11. LED Service/ Warning/ Alarm
12. Enter / Quit
13. Graphic display
14. Pressure gauge left cartridge
15. Pressure gauge right cartridge

	Power On	white: Voltage applied green: Dryer on green flashes: Dryer (Remote) off
	Dryer in Remote Operation	green: at terminal green flashing: at Modbus
	Warning/Service/Alarm	yellow for service, for warning yellow flashing, flashing has priority! for alarm red, flashing has priority! red by wire break PDP-Sensor for PDP-Alarm red flashing

6.5.1 Start Screen



Basic Menu

If there is a PDP sensor, the first line indicates the pressure dew point; if there is no sensor, the first line is empty!

Dryer On, without PDP-Sensor



Dryer On, with PDP-Sensor (Option)

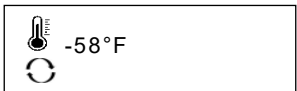

Dryer Off, without PDP-Sensor



Dryer Off, with PDP-Sensor (Option)

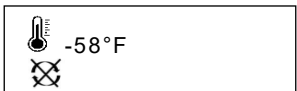

Press to move to:

Shows hours with operating voltage

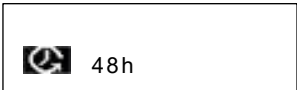

Press to move to:

Shows the hours until the next service



Press to move to:

Shows the software version



Press to move to:

Dryer On, without PDP-Sensor

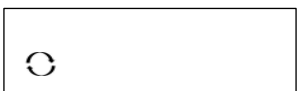

or after approx. 1 minute without input.

6.5.2 Message History

By briefly pressing , you get to the message display.

Press again briefly to return to "Basic menu", or after 2 minutes and 30 seconds.

The messages are numbered at the top right (1 is the latest, maximum 20 messages, fifo system)

Press to scroll through the messages .:

- Warnings cause the warning / service relay to drop.
- Alarms cause the alarm relay to drop.

Possible messages:

- 202 Drain Warning (deactivates the Relay warning / service) yellow LED flashes
- 310 Service time expired (Relay warning / service) yellow LED glows
- 204 DTP alarm (deactivates the Relay Alarm) red LED flashes
- 210 DTP sensor cable break deactivates the Relay Alarm) red LED lights

If power failure message 204 is suppressed for 10 minutes, message 202 is also suppressed.

Examples:

1st Message (newest)

Message 202, at 2891 hours with operating voltage



5. Message (5 newest)

Message 310, at 2602 hours with operating voltage



12. Message (12 newest)

Message 204, at 2001 hours with operating voltage



18. Message (18 newest)

Message 210, at 308 hours with operating voltage



6.5.3 Remote On/Off Settings

Mode A:

With Remote Off, the cycle is stopped, the solenoid valves are switched off.

With Remote On, the cycle continues at the same point.

Optimized for reciprocating compressors!

Dip switch 6 on OFF.

Mode B:

With Remote Off, the half-cycle is stopped at the end, and the solenoid valves are switched off.

With Remote On, the cycle continues at the same point.

Optimized for the desiccant dryer!

Dip switch 6 on ON.

Remote On Mode A

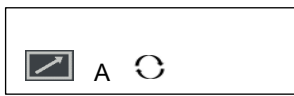

Remote On Mode B

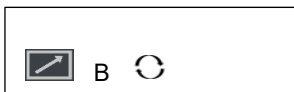

Remote Off Mode A

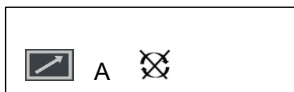

Remote Off Mode B



6.5.4 Setting Menu

Press and hold button for approximately 3 seconds.

Target pressure dewpoint

Now appears (Set pressure dewpoint):

PDP sensor installed and activated



or

PDP sensor disabled

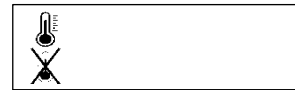

Pressing marks the number/symbol in the second line.

By further pressing the button, the scrolling will continue:

; -80°C/-112°F; -79°C/-110°F; ...; -21°C/-5.8°F; -20°C/-4°F;

Meanings:

PDP control switched off

e.g. -40°C/-40°F Target PDP is -40°/-40°F C

Pressure dewpoint alarm (if PDP sensor installed and activated)

By pressing , you move to (pressure dewpoint alarm):

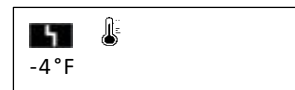

Pressing marks the number in the second line.

Press the button again to scroll through:

The setting range is between (target pressure dewpoint + 5°C/41°F) and 0°C/32°F.

Example:

Target pressure dewpoint: -37°C/-34,6°F

Pressure dewpoint alarm setting range: -32°C/-25.6°F to 0°C/32°F

The following options are available:

(-32°C/-25.6°F; -31°C/-23.8°F; ...; -1°C/30.2°F; 0°C/32°F; -32°C/-25.6°F)

Service Counter

Press  to move to (Reset Service Counter):

```
no
```

Pressing  marks „no“ in the second line.

By further pressing the  button, you can choose between "no/yes".

```
no
```

```
yes
```

If "Yes" is selected, the service time counter is set to the default value.

IP-Address

Press  to move to (Enter IP address):

```
IP-Address  
169.254.100.095
```

Pressing  marks number/symbol in the second line.

By further pressing the  button the numbered block is incremented:

```
IP-Address  
169.254.100.095
```

By pressing , you move to the next number block:

```
IP-Address  
169.254.100.095
```

If the mark disappears after a few seconds, the value is accepted.

The final transfer to the control memory only takes place when the setting menu is exited via the  button or via a cold start.

Subnet-Address

Press  to move to (Enter Subnet Address):

```
Subnet  
255.255.000.000
```

Pressing  marks number/symbol in the second line.

By further pressing the  button the numbered block is incremented:

```
Subnet  
255.255.000.000
```

By pressing , you move to the next number block:

```
Subnet  
255.255.000.000
```

If the mark disappears after a few seconds, the value is accepted.

The final transfer to the control memory only takes place when the setting menu is exited via  the button or via a cold start.

Gateway-Address

Press  to move to (Enter Gateway address):

```
Gateway  
169.254. 100.100
```

Pressing  marks number/symbol in the second line.

By further pressing the  button the numbered block is incremented:

```
Gateway  
169.254. 100.100
```

By pressing , you move to the next number block:

```
Gateway  
169.254. 100.100
```

If the mark disappears after a few seconds, the value is accepted.

Press  again briefly to return to "Basic menu", or after 2 minutes and 30 seconds.

The final transfer to the control memory only takes place when the setting menu is exited via the  button or via a cold start.

Service Technician Menu

Keep the  button pressed for approximately 5 seconds.

Password
0000

By pressing , the 1st digit of the second line is marked.

By further pressing the  button the marked digit is incremented:



Password
0000

Press  to move to the next digit:

Password
0000

If the marking disappears after a few seconds, the password entered in this way is accepted.

If entered correctly, the default value of the Service Counter and the operating hours can also be set in the Settings menu.

 
8760h

000157h

Press  again briefly to return to "Basic menu", or after 2 minutes and 30 seconds.

6.6 Purge Air Consumption

Dryer is designed to operate either in 8 minute (-40°F/-40°C) or 4 minute (-94°F/-70°C) cycle.

6.6.1 Maximum Purge Flow

Maximum purge flow is the amount of purge flowing through the off-stream tube when the purge/repressurization valve is open. After the purge/repressurization valve closes the purge flow will gradually decrease as the off-stream tube repressurizes to line pressure.

6.6.2 Average Purge Flow

The average purge flow is the actual amount of flow averaged over the entire purge/repressurization cycle. It includes the maximum purge flow for a set amount of the purge/repressurization time and the volume of air used for repressurization.

6.6.3 Minimum Outlet Flow

Determine minimum outlet flow available from dryer by subtracting maximum purge flow from inlet flow to dryer (specification by authorized dealer).

IMPORTANT: Air compressor should be adequately sized to handle air system demands as well as purge loss. Failure to do so could result in overloading air compressors and/or insufficient air supply downstream.

6.6.4 Timer Board Setting & Remote Control

With the dryer de-energized (disconnect plug), verify position of the cycle time DIP switches. The DIP switches are located on the timer board in the cabinet.

Dip-switches	Meaning	Dip-switch * OFF	Dip-switch ON
1	Selection of cycles	see table	see table
2	Selection of cycles	OFF	
3	Selection of cycles	OFF	
4	Local / Remote operation	Local	Remote operation
5	Remote Off via Modbus	deactivated	activated
6	Remote Off Mode A / B	Mode A	Mode B
7	°C / °F	°C	°F
8	Reserve	OFF	

* Factory setting: DIP Switch 7 is "ON". All other DIP switches are "OFF"

Scheme	Dip 1	Dip 2	Dip 3
-40°C / -40°F ↔ <10bar/ 145psig	OFF	OFF	OFF
-70°C / -94°F ↔ <10bar/ 145psig	ON	OFF	OFF
-40°C / -40°F ↔ >10bar/ 145psig	OFF	ON	ON
-70°C / -94°F ↔ >10bar/ 145psig	ON	OFF	ON

7.0 Servicing and Maintenance

WARNING – The heatless desiccant dryer is a pressure containing device. Depressurize the dryer before servicing or repairing. (See section 7.5.)

ATTENTION!

Before starting any service work ensure all power is isolated from the dryer. A power plug (if fitted) should be unplugged.

7.1 Nameplate

The nameplate contains all information to identify your dryer. Please provide the information from the nameplate with every enquiry and when ordering replacement parts.

7.2 Ordering Consumable Parts and Operating Materials

Use only genuine replacement parts from the manufacturer. The manufacturer bears no responsibility for hazards caused by the use of unauthorized parts .

WARNING – There is risk of personal injury or damage to the machine resulting from the use of unsuitable spares or operating materials. Unsuitable or poor quality consumable parts and operating materials may damage the machine or impair its proper function. Personal injury may result from damage.

For continued good performance of your dryer, all regular dryer maintenance should be performed by an authorized service technician.

7.3 Weekly Maintenance

NOTE: The components specified in parentheses (e.g. B006) refer to the P&I-schematic diagram.

- A. Check the residual pressure in the tubes (B006 and B007) during the regeneration with the gauges (PI018 and PI019).
- B. If the residual pressure level rises above 0.3 bar/ 4.4psi, the purge mufflers must be replaced.
 - 1) Switch off the dryer (see chapter 5. "Switching off the dryer").
 - 2) Replace the purge mufflers.
 - 3) Switch on the dryer.
- C. Check the differential pressure gauge from the pre- and after filter (F001, F012) (see instruction manual filter). Replacement filter elements (see section 7.4 "Annual maintenance").
- D. Check the automatically condensate drain at the pre-filter.

7.4 Annual Maintenance

NOTE: The components specified in parentheses (e.g. B006) refer to the P&I-schematic diagram.

- A. Replace the filter cartridges from the pre- and after filter (F001 and F012).
 - 1) Depressurize the dryer (see chapter 7.5 "Depressurizing the desiccant dryer").
 - 2) Switch off the dryer (see chapter 5. "Switching off the dryer").
 - 3) Replacing the filter cartridges see filter instruction manual.

- B. Replace condensate drain.
- C. Replace the purge mufflers (see section 7.3 "Weekly maintenance").

7.5 Depressurize the Desiccant Dryer

NOTE: The components specified in parentheses (e.g. B006) refer to the P&I-schematic diagram.

- A. Close the shut-off devices in the compressed-air inlet- and outlet line.
- B. Let the desiccant dryer run through a complete tower change cycle or until all air has been exhausted from the dryer.
- C. Check the residual pressure in the tubes (PI018 and PI019).

7.6 Replacement of Desiccant

A. Frequency Of Desiccant Replacement

Desiccant should be replaced whenever the required dew point cannot be maintained while the dryer is being operated within its design conditions and there are no mechanical malfunctions.

NOTE: Desiccant life is determined by the quality of the inlet air. Proper filtering of the inlet air will extend the life of the desiccant. Typically desiccant life is 2 years.

B. Procedure for Desiccant Charge Replacement

1. Depressurize the dryer (see chapter 7.5 "Depressurizing the desiccant dryer").
2. Switch off the dryer (see chapter 5. "Switching off the dryer").
3. Remove the front panel of the dryer.
4. Loosen the nuts / washers of the upper manifold and remove it.
5. Remove the gasket and metal mesh. Remove the threaded rods.
6. Remove the aluminum profiles and remove the cartridge with the aid of the attached knurled screw.
7. Replace the lower metal mesh and gaskets and reassemble the new threaded rods and profiles back.
8. Insert the cartridges and replace the upper metal mesh and gaskets.
9. Mount the distributor block and the front plate of the dryer.
10. Torque:
DSHD-7 - DSHD-21: 15Nm (nuts/ threaded rods)
DSHD-27 - DSHD-40: 20Nm (nuts/ threaded rods)
11. After replacing the desiccant, restart the dryer as described in chapter 6.

IMPORTANT: Keep the desiccant cartridges with the new desiccant closed until they are used, to avoid moisture contamination.

7.6.1 Replacement of Purge Solenoid Valves

NOTE: The components specified in parentheses (e.g. B006) refer to the P&I-schematic diagram.

- A. Change solenoid purge valves (V014/V015) after 5 years of full operation.

7.7 Prefilter/Afterfilter Maintenance

A. Element Replacement

1. For maximum filtration efficiency, replace element annually or when pressure drop reaches 4.3 psi (0.3 bar) (indicator in red area), whichever occurs first.

B. Procedure for Element Replacement

WARNING: THIS FILTER IS A PRESSURE CONTAINING DEVICE. DEPRESSURIZE BEFORE SERVICING.

1. Isolate filter (close inlet and outlet valves if installed) or shut off air supply.
2. Depressurize filter by slowly opening manual drain valve.
3. Remove bowl by unscrewing the bowl from the filter head using hand, strap wrench or C spanner, and pulling bowl straight down.
4. Clean filter bowl.
5. Replacing complete element.
 - a) Pull off old element and discard.
 - b) Make certain that the old and new element have the same part number and the end caps are the same color.
 - c) Wipe the wall inside the filter head to remove any dirt.
 - d) Lubricate the new element o-ring on the element top cap.
 - e) Align the slot in the element top cap with the projection inside the filter head.

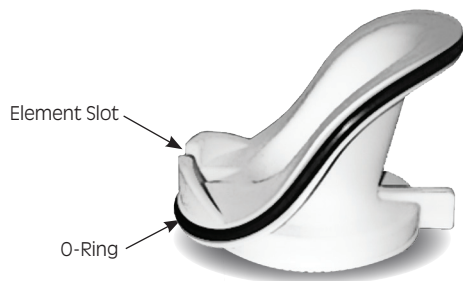
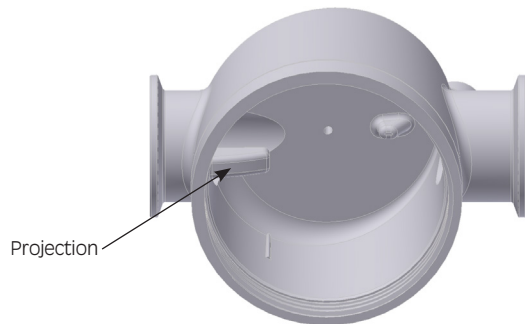

- f) Insert the element into the head making sure the element slot and the projection inside the filter head remain aligned.

NOTE: Handle all elements by bottom end cap only.

6. Replace housing o-ring (located at the top of the filter bowl) if needed. Make certain o-ring is generously lubricated (Use lubricant provided).
7. Reassemble bowl to head.

NOTE: Threaded bowl to head connection, generously lubricate threads with a high grade/temperature lubricant 150°F (66°C). (Use lubricant provided)

C. Auto Drain Mechanism Replacement

Prefilter only: It is recommended that drain mechanism be replaced annually.

8.0 Troubleshooting Guide

NOTE: Refer to the P&I-schematic diagram and Dimensional Drawings for components specified in parentheses (e.g. B006).

WARNING – A POTENTIAL ELECTRICAL SHOCK HAZARD EXISTS. Some of the troubleshooting checks may require gaining access to the dryer's electrical enclosure while the power supply is energized and should be performed by a qualified electrical technician

WARNING – Before performing any electrical or mechanical repairs or maintenance, or removing or disassembling any component, be sure to de-energize and depressurize the dryer

Water in the compressed-air system	
Possible Cause	Remedy
Condensate residues which formed prior to starting up the dryer are in the compressed-air system	Blow out compressed-air system with dry air until no more moisture is condensed out. Open collection point at most remote position, if possible.
Bypass open.	Close bypass.
Condensate from the prefilter not separated.	Carry out check by trained staff and repair, if necessary.
The operating parameters have changed since the desiccant dryer was installed.	Correct to the original operating parameters as the dryer was designed.
High pressure loss through the desiccant compressed air dryer	
Possible Cause	Remedy
The capacity of the pre and/or -after filter cartridge are overload.	Replace the filter cartridge (see annex filter).
The operating parameters have changed since the desiccant dryer was installed.	Restore the operating conditions for which the dryer was designed.
Display: 310	
(LED Warning/ Service/ Alarm glows yellow)	
(Service time expired, leads to deactivation of the relay warning / service)	
Possible Cause	Remedy
Service time expired	Carry out maintenance and reset service counter.

Display: 202 (LED Warning/ Service/ Alarm flashes yellow) (Drain warning, leads to deactivation of the relay warning / service)	
Possible Cause	Remedy
Condensate not separated.	Press TEST-button on the condensate discharger (X001/ see chapter 12). <u>Condensate is not discharged:</u> - Check power supply to solenoid coil. In case of power on this terminal replace printed circuit board. - Check if dryer and condensate discharger are pressurized (min. 0.8bar /11.6psi). If they are pressurized check if outlet pipe behind the condensate discharger is blocked. Yes: Clean pipe and remove any obstruction. No: Disconnect dryer and condensate discharger from power supply (main switch / fuse) and ensure that device is in a pressure-less state. Dismantle solenoid diaphragm, remove any obstruction and examine diaphragm. If diaphragm is damaged replace with new one. During this procedure, it is possible to replace also all seals and the coil core. Housing and sensors should be thoroughly cleaned at the same time. <u>Condensate and air are discharged, but ALARM -signal continues</u> - Disconnect dryer and condensate discharger from power supply (main switch / fuse) and ensure that device is in pressureless state. Open condensate discharger and clean sensor thoroughly.
Display: 204 (LED Warning/ Service/ Alarm flashes red) (PDP Alarm, leads to deactivation of the relay alarm)	
Possible Cause	Remedy
Desiccant dryer only switched on briefly.	Operate desiccant dryer for some time with low load.
Desiccant dryer overload.	Adapt the operating conditions to the permitted parameters.
Ambient temperature too high.	
Air inlet temperature high.	
Volumetric flow rate too high.	
Operation pressure too low.	
PDP sensor defective (PT029)	Check the PDP sensor and replace, if necessary.
Display: 210 (LED Warning/ Service/ Alarm glows red) (PDP Sensor cable break, leads to deactivation of the relay alarm)	
Possible Cause	Remedy
PDP Sensor cable break	Check the electrical connection, replace if necessary.
PDP sensor not connected	PDP-control switch off (see chapter 6.5.4)

9.0 Technical Data

Specification according to DIN ISO 7183 Option A2

IMPORTANT: Should any data change which is marked with an asterisk (*), all other data in that section may also change.

9.1 Maximum Purge Flow

		DSHD-7	DSHD-13	DSHD-18	DSHD-21	DSHD-27	DSHD-40
Min. inlet temperature	°F / °C	+ 35.6 / + 2					
* Inlet temperature	°F / °C	+100 / + 38					
Max. inlet temperature	°F / °C	+ 122 / + 50					
* Outlet temperature	°F / °C	+100 / + 38					
* Air flow (relating to +20°C compressed air induction temperature and 1 bar absolute)	scfm	7	13	18	21	27	40
	m ³ /h	12	22	31	36	46	68
* Pressure dewpoint at working pressure	°F / °C	- 40 / - 40					
Min. working pressure	psi/bar	58 / 4					
* Working pressure [PO]	psi/bar	100 / 7					
Allowable pressure [PS]	psi/bar	217.5 / 15					
* Differential pressure inlet / outlet (without filtration)	psi/bar	≤ 2.18 / ≤ 0.15					
Compressed air connection (without filtration)	NPT	1/2				3/4	

9.2 Ambient Temperature

		DSHD-7	DSHD-13	DSHD-18	DSHD-21	DSHD-27	DSHD-40
Ambient temperature	°F / °C	+ 100 / + 38					
Min. ambient temperature	°F / °C	+ 35.6 / + 2					
Max. ambient temperature	°F / °C	+ 104 / + 40					

9.3 Electrical Data

		DSHD-7	DSHD-13	DSHD-18	DSHD-21	DSHD-27	DSHD-40
Voltage	V	120 ±10% / 1 Ph					
Frequency	Hz	50 - 60					
Nominal power	W BTU/hour	50 / 171					
Nominal current	A	0.7					
Max. pre-protection	A	16					
Max. connection cross section	mm ²	3 x 1.5					
* Noise level chart (Equivalent level of continuous acoustic pressure in the distance of 1m in a free field (Leq))	dB (A)	60	62	62	62	62	63
* Noise level chart (The level of short- term sound pressure at the distance of 1m in open space (LpA))	dB (A)	74	74	75	76	77	78

9.4 Desiccant

		DSHD-7	DSHD-13	DSHD-18	DSHD-21	DSHD-27	DSHD-40
Desiccant		Activated alumina					
Volume profile	gal	0.68	0.99	1.37	1.75	2.32	2.97
Charge per tower (Cartridge)	lb	4.10	6.13	8.71	11.35	14.88	19.29

9.5 Condensate

		DSHD-7	DSHD-13	DSHD-18	DSHD-21	DSHD-27	DSHD-40
Condensate separator connection (pre-filter)		See filter instruction manual					

9.6 Measurements, Weights

		DSHD-7	DSHD-13	DSHD-18	DSHD-21	DSHD-27	DSHD-40
Height / Width / Depth	inch	See dimensional drawing					
Weight	lb	61.3	77.2	97.4	117.7	136.2	165

9.7 Nominal Air Flow

Model	DTP [°F]	Max. air flow inlet [scfm] ¹
DSHD-7	- 40	7
DSHD-13	- 40	13
DSHD-18	- 40	18
DSHD-21	- 40	21
DSHD-27	- 40	27
DSHD-40	- 40	40
DSHD-7	- 94	5
DSHD-13	- 94	9
DSHD-18	- 94	12
DSHD-21	- 94	14
DSHD-27	- 94	18
DSHD-40	- 94	27

1) According to CAGI (Compressed Air and Gas Institute) standard ADF-200, Dual Stage Regenerative Desiccant Compressed Air Dryers - Methods for Testing and Rating. Conditions for rating dryers are: inlet pressure - 100 psig (7 kg/cm²); inlet temperature - saturated at 100°F (38°C)

9.8 Correction Factors

Correction factor for working pressure												
Working pressure (psi)	58	72	87	100	116	131	145	160	174	189	203	218
Working pressure (bar)	4	5	6	7	8	9	10	11	12	13	14	15
$K_{p(i)}$	0.40	0.57	0.77	1.00	1.13	1.25	1.38	1.38	1.50	1.56	1.61	1.67

Correction factor for compressed air inlet temperature						
Compressed air inlet temperature (°F / °C)	86 / 30	95 / 35	100 / 38	104 / 40	113 / 45	122 / 50
$k_{T(i)}$ (DTP = -40°C / °F)	1.07	1.07	1.00	0.93	0.82	0.72

10.0 Replacement Parts & Maintenance Kits

10.1 Replacement Parts

	DSHD-7	DSHD-13	DSHD-18	DSHD-21	DSHD-27	DSHD-40
Filter Adapters	7443512				7443513	
Plugs	7443514				7443515	
Controller	7443516					
Gauge	7443517					
Top Block	7443518				7443519	
Bottom Block	7443520				7443521	
Solenoid Valve	7443522					
Front Panel	7443523	7443524	7443525	7443526	7443527	7443528
Base Plate	7443529				7443530	
Muffler Core	3116957					
Orifice	7443531	7443532	7443533	7443534	7443535	7443536
Plastic Caps	7443537					
Solenoid Adapters	7443538					

10.2 Maintenance Kits

		DSHD-7	DSHD-13	DSHD-18
Year 2 Maintenance Kit	Filter Elements, Muffler Cores, Drain	DSHDMK7-2-4 (7458620)	DSHDMK13-2-4 (7458621)	DSHDMK18-2-4 (7458622)
Year 3 Maintenance Kit	Filter Elements, Muffler Cores, Drain, Desiccant Cartridge	DSHDMK7-3-5 (7458614)	DSHDMK13-3-5 (7458615)	DSHDMK18-3-5 (7458616)
Year 4 Maintenance Kit	Filter Elements, Muffler Cores, Drain	DSHDMK7-2-4 (7458620)	DSHDMK13-2-4 (7458621)	DSHDMK18-2-4 (7458622)
Year 5 Maintenance Kit	Filter Elements, Muffler Cores, Drain, Desiccant Cartridge	DSHDMK7-3-5 (7458614)	DSHDMK13-3-5 (7458615)	DSHDMK18-3-5 (7458616)

		DSHD-21	DSHD-27	DSHD-40
Year 2 Maintenance Kit	Filter Elements, Muffler Cores, Drain	DSHDMK21-2-4 (7458623)	DSHDMK27-2-4 (7458624)	DSHDMK40-2-4 (7458625)
Year 3 Maintenance Kit	Filter Elements, Muffler Cores, Drain, Desiccant Cartridge	DSHDMK21-3-5 (7458617)	DSHDMK27-3-5 (7458618)	DSHDMK40-3-5 (7458619)
Year 4 Maintenance Kit	Filter Elements, Muffler Cores, Drain	DSHDMK21-2-4 (7458623)	DSHDMK27-2-4 (7458624)	DSHDMK40-2-4 (7458625)
Year 5 Maintenance Kit	Filter Elements, Muffler Cores, Drain, Desiccant Cartridge	DSHDMK21-3-5 (7458617)	DSHDMK27-3-5 (7458618)	DSHDMK40-3-5 (7458619)

Phone: 724-745-1555
 Email: ft.dehydration.order.entry@spxflow.com
 Web: www.spxflow.com/deltech

11.0 Drawings

11.1 General Arrangement: DSHD-7

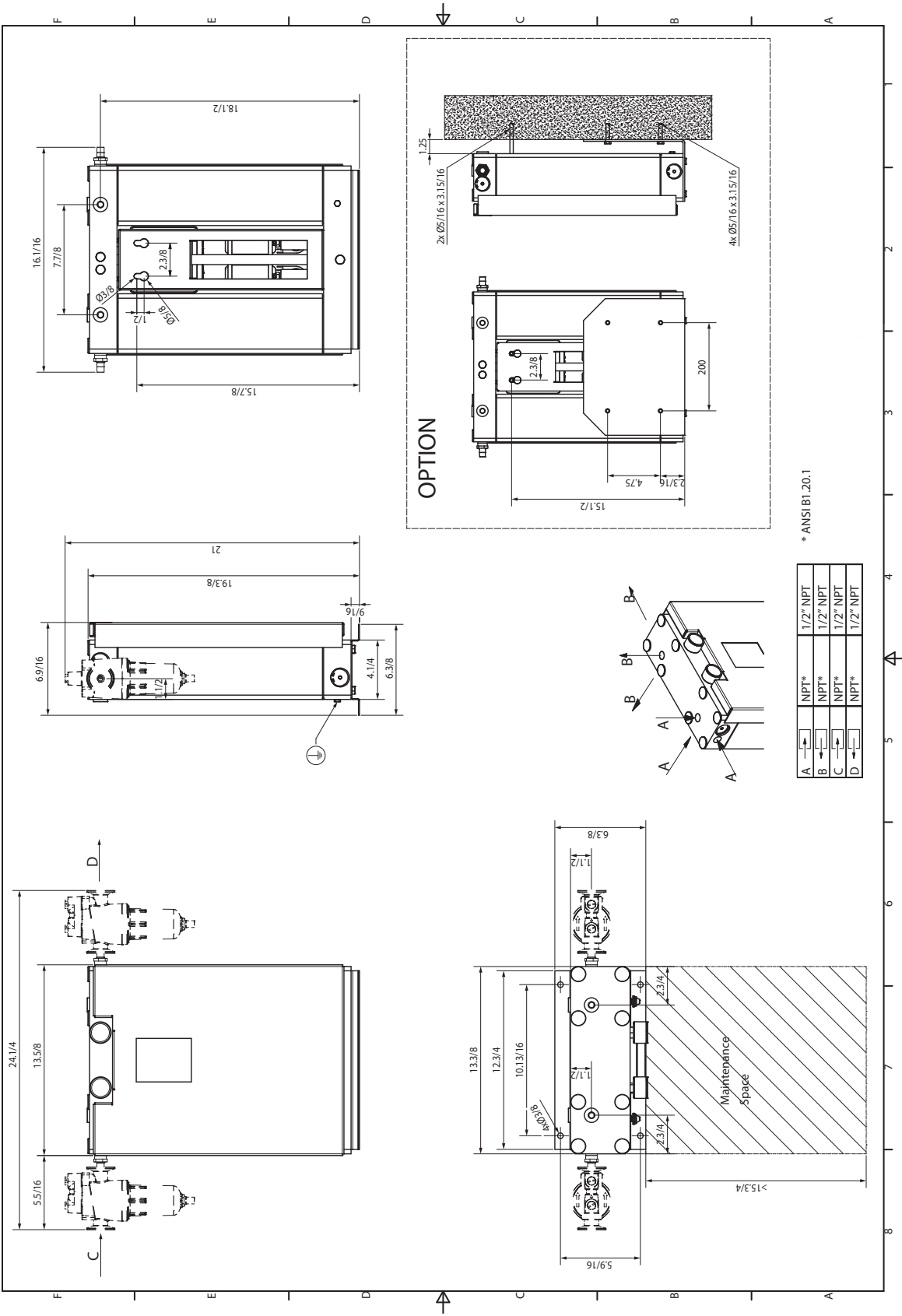

11.2 General Arrangement: DSHD-13

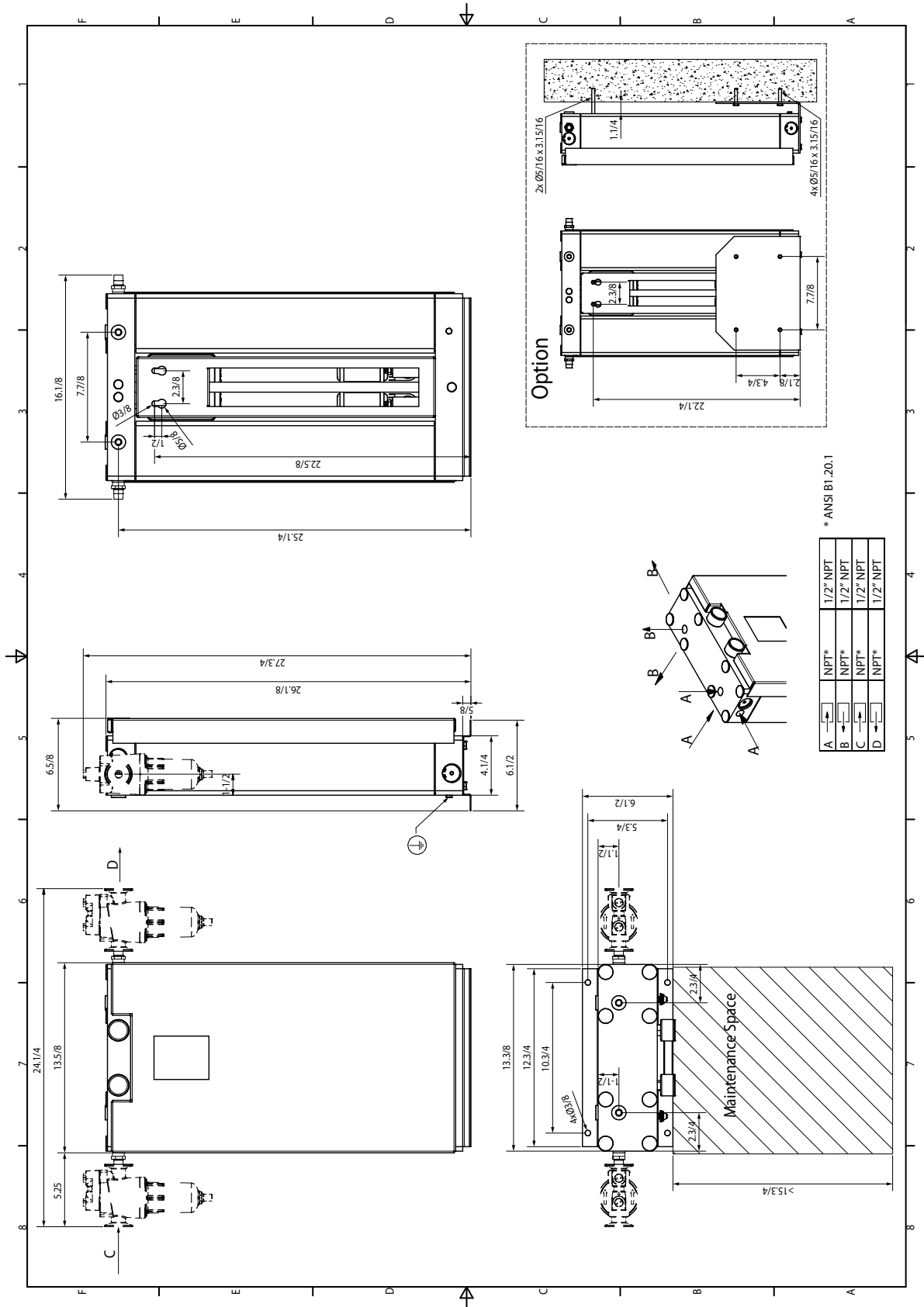

11.4 General Arrangement: DSHD-21

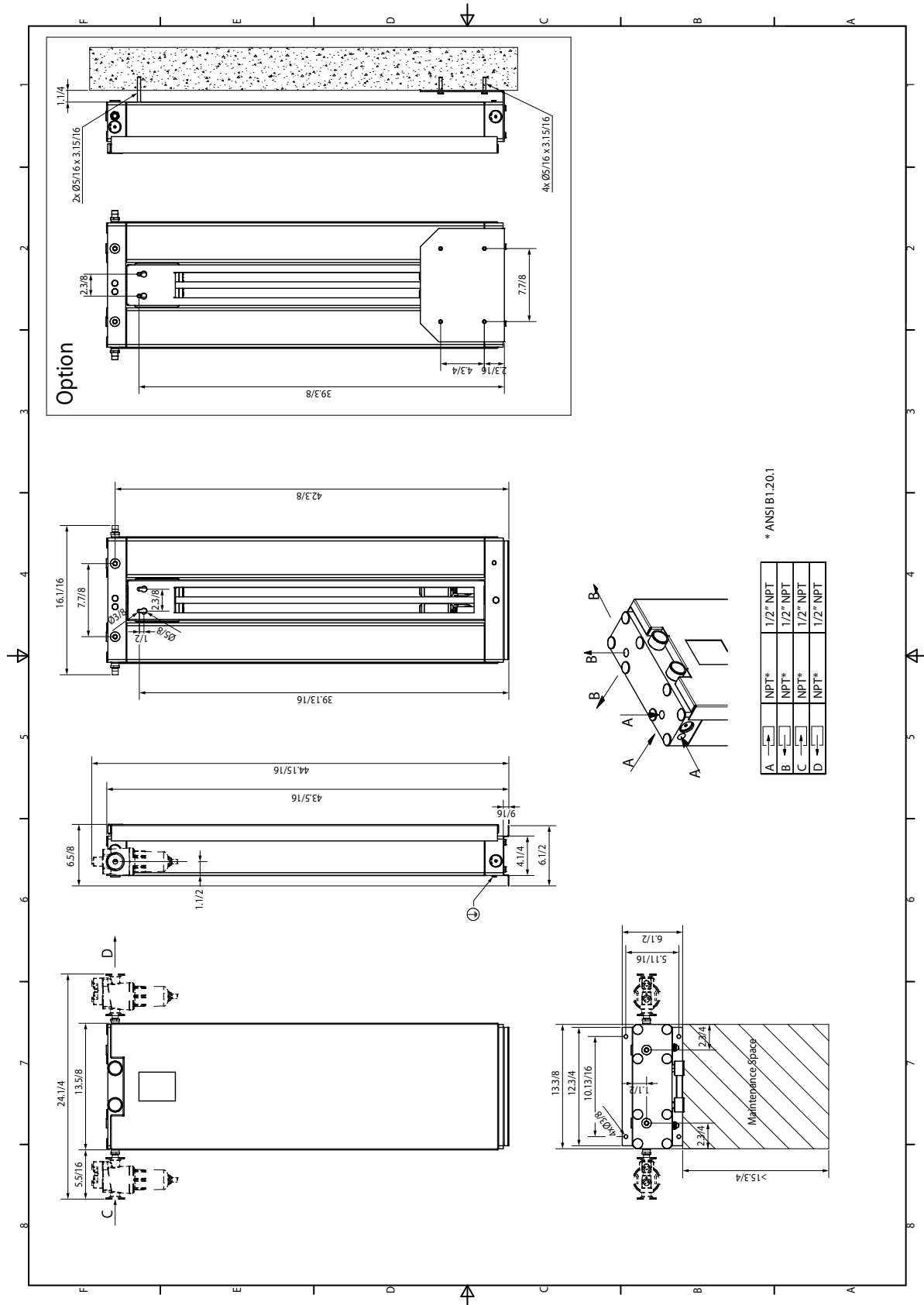

11.5 General Arrangement: DSHD-27

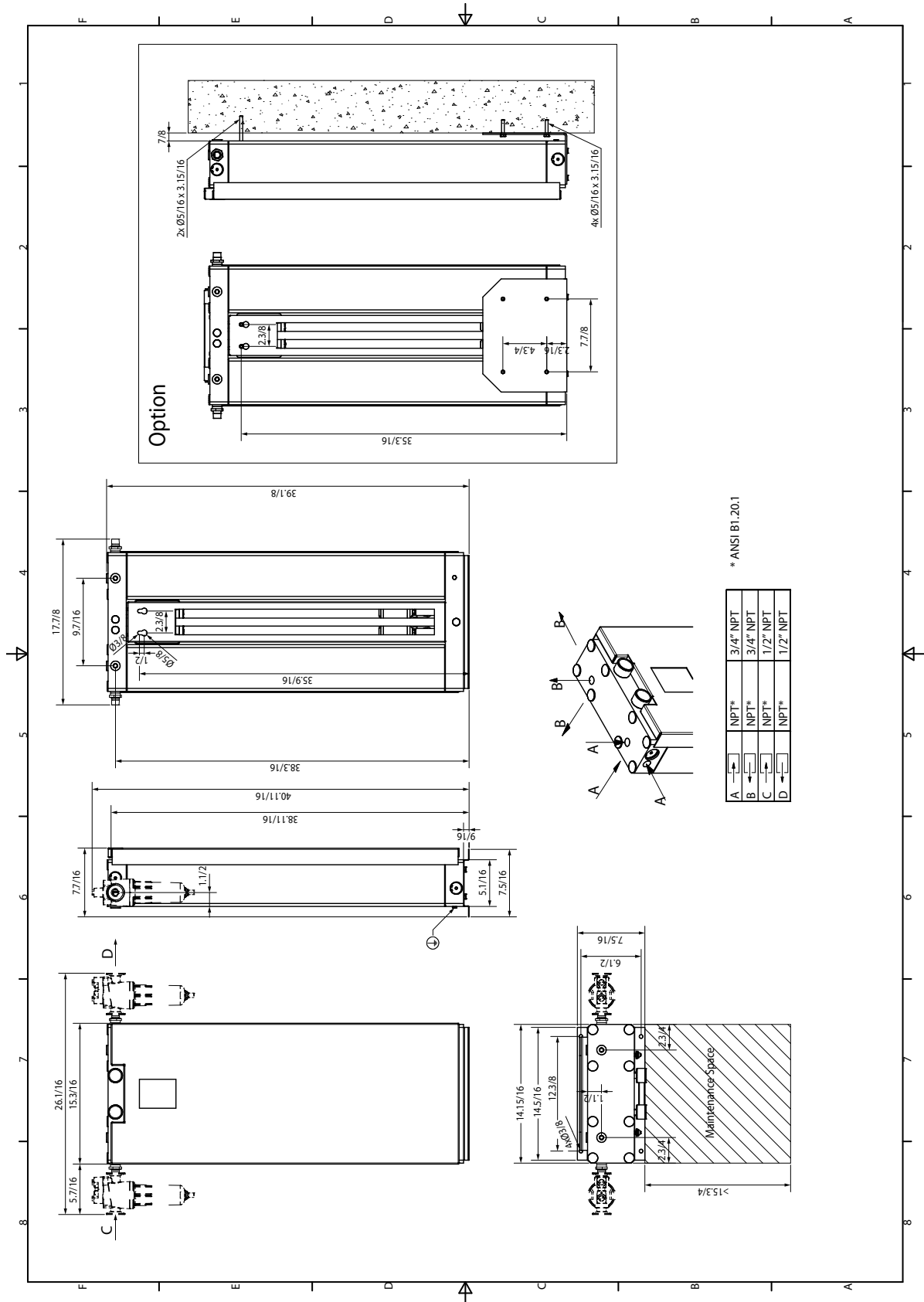

11.7 P&I Diagram

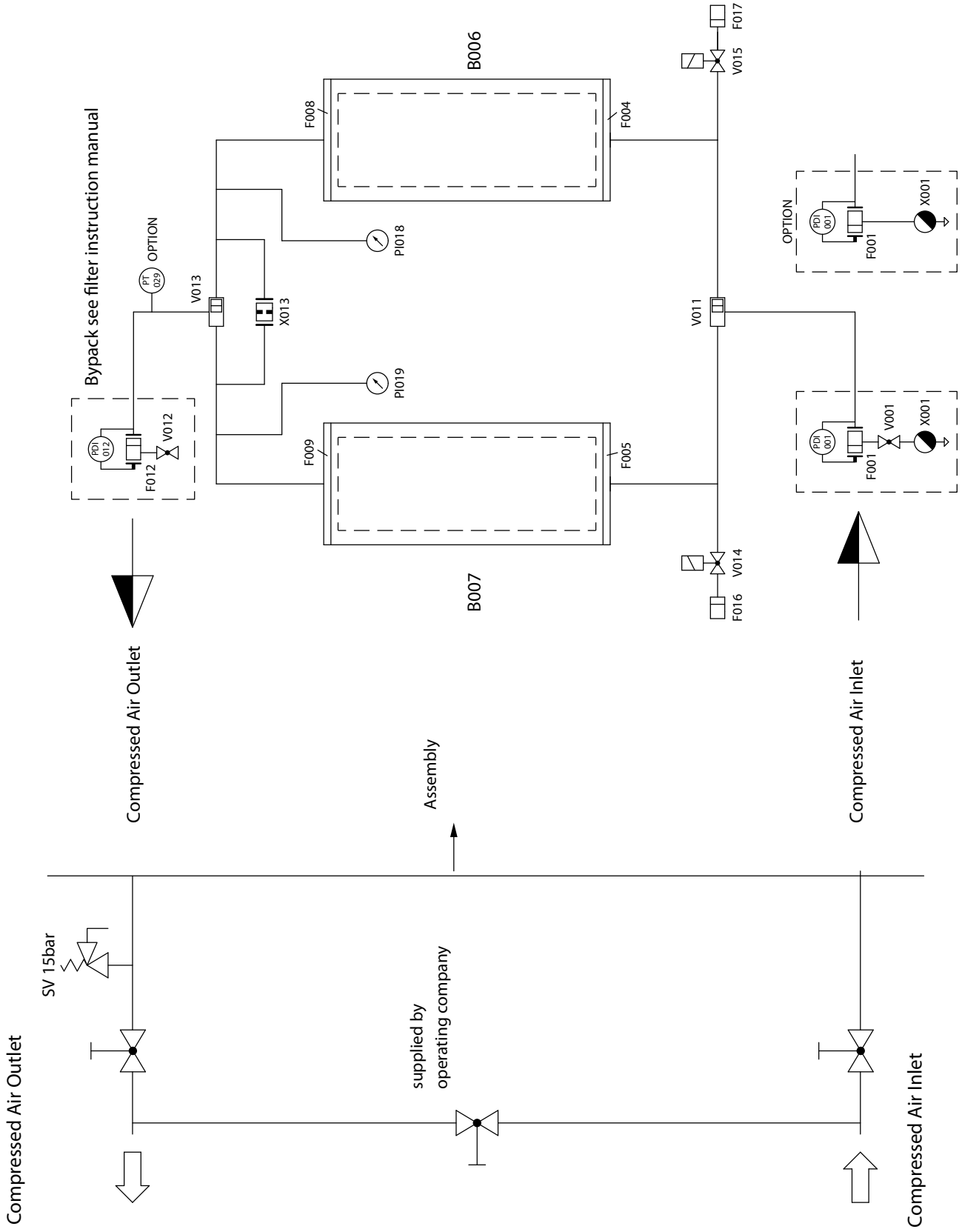

P&I Diagram

LEGEND

B006/B007	Desiccant Cartridge
F001	Pre-Filter (Option)
F004/F005/F008/F009	Block Protection Mash
F012	Afterfilter (Option)
F016/F017	Muffler
PDI001/PDI012	Differential Pressure Gauge
PI018/PI019	Pressure Gauge
PT029	Pressure Dewpoint Sensor (Option)
V001/V002	Shut-off Valve (Option)
V011	Bottom Block
V013	Top Block
V014/V015	Solenoid Valve (Purge)
X001	Condensate Drain
X013	Orifice

11.8 Electrical Schematic

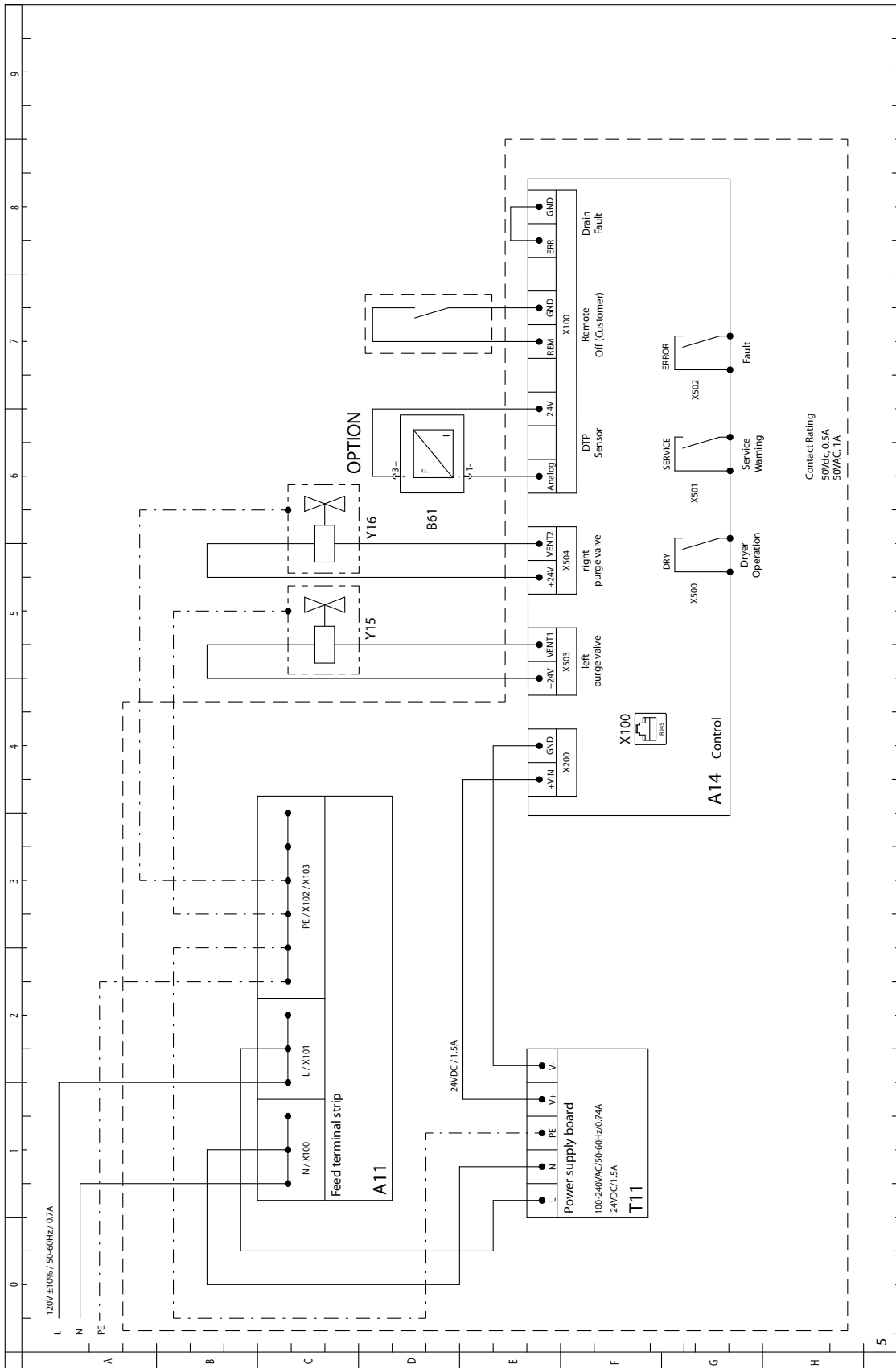

11.9 Electrical Schematic With Electronic Drain Option

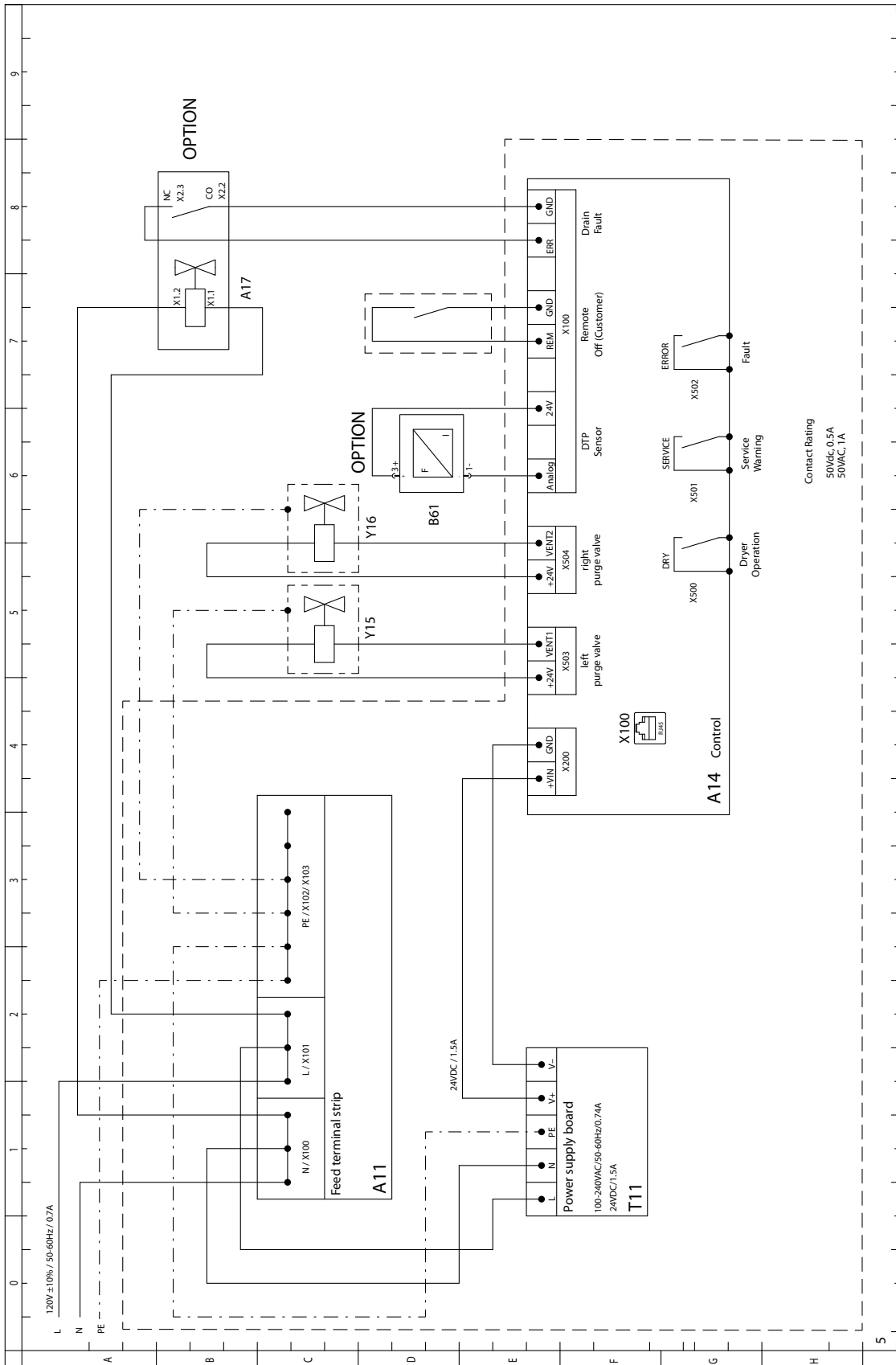

WARRANTY

The manufacturer warrants the product it manufactures, when properly installed, operated, applied, and maintained in accordance with procedures and recommendations outlined in manufacturer's instruction manuals, will be free from defects in material or workmanship for a period as specified below, provided such defect is discovered and brought to the manufacturer's attention within the aforesaid warranty period.

The manufacturer will repair or replace any product or part determined to be defective by the manufacturer within the warranty period, provided such defect occurred in normal service and not as a result of misuse, abuse, neglect or accident. Normal maintenance items requiring routine replacement are not warranted. The warranty covers parts and labor for the warranty period unless otherwise specified. Repair or replacement shall be made at the factory or the installation site, at the sole discretion of the manufacturer. Although not required for warranty consideration, it is recommended that the manufacture be contacted prior to doing any warranty related service work. This action will provide guidance and instruction on the repair often times authorization to perform the work. NOTE: The manufacture reserves the right to repair, replace in the case of warranty approval or reject the warranty claim once submitted.

Unauthorized service and use of unauthorized or pirated parts voids the warranty and any resulting charges or subsequent claim will not be paid. Products repaired or replaced under warranty shall be warranted for the unexpired portion of the warranty applying to the original product.

The foregoing is the exclusive remedy of any buyer of the manufacturer's product. The maximum damages liability of the manufacturer is the original purchase price of the product or part.

THE FOREGOING WARRANTY IS EXCLUSIVE AND IN LIEU OF ALL OTHER WARRANTIES, WHETHER WRITTEN, ORAL, OR STATUTORY, AND IS EXPRESSLY IN LIEU OF THE IMPLIED WARRANTY OF MERCHANTABILITY AND THE IMPLIED WARRANTY OF FITNESS FOR A PARTICULAR PURPOSE. THE MANUFACTURER SHALL NOT BE LIABLE FOR LOSS OR DAMAGE BY REASON OF STRICT LIABILITY IN TORT OR ITS NEGLIGENCE IN WHATEVER MANNER INCLUDING DESIGN, MANUFACTURE OR INSPECTION OF THE EQUIPMENT OR ITS FAILURE TO DISCOVER, REPORT, REPAIR, OR MODIFY LATENT DEFECTS INHERENT THEREIN. THE MANUFACTURER, HIS REPRESENTATIVE OR DISTRIBUTOR SHALL NOT BE LIABLE FOR LOSS OF USE OF THE PRODUCT OR OTHER INCIDENTAL OR CONSEQUENTIAL COSTS, EXPENSES, OR DAMAGES INCURRED BY THE BUYER, WHETHER ARISING FROM BREACH OF WARRANTY, NEGLIGENCE OR STRICT LIABILITY IN TORT.

Please note that the manufacturer's warranty for this product is intended to cover manufacturing defects and therefore does not cover consumable components (desiccants, filter elements, soft goods, standard maintenance kit wear items, etc.) or components that require periodic user adjustment (expansion valve, hot gas bypass valve or cooling water regulating valve) or calibration (dew point elements/sensors, gauge calibration, etc.)

Warranty Period

One (1) year parts and labor from the date of shipment from the manufacturer or the manufacturer's authorized distributor (not to exceed eighteen (18) months from the date of shipment from the factory, whichever occurs first).

An extended warranty of up to 5 years from the date of purchase may be available for your dryer. Please contact your local distributor for more details of the requirements for activation of warranty extension.

AUTHORIZATION FROM THE SERVICE DEPARTMENT IS NECESSARY BEFORE MATERIAL IS RETURNED TO THE FACTORY OR IN-WARRANTY REPAIRS ARE MADE.

SERVICE DEPARTMENT: (724) 746-1100

DSHD SERIES

Desiccant Compressed Air Dryer

Models: DSHD-7, DSHD-13,
DSHD-18, DSHD-21,
DSHD-27, DSHD-40

SPXFLOW[®]

SPX FLOW, INC.

4647 S.W. 40th Avenue

Ocala, Florida 34474-5788 U.S.A.

P: (724) 745-1555

E: ft.dehydration.order.entry@spxflow.com

www.spxflow.com/deltech

Improvements and research are continuous at SPX FLOW, Inc.

Specifications may change without notice.

ISSUED 10/2020 Form No.: 7443488 Revision: None

COPYRIGHT ©2020 SPX FLOW, Inc.