

CATALITE® BREATHING AIR PURIFIERS

CBA SERIES

FORM NO.: 3215426 REVISION: 04/2022

READ AND UNDERSTAND THIS MANUAL PRIOR TO OPERATING OR SERVICING THIS PRODUCT.

MODELS	INLET RATED FLOW	OUTLET RATED FLOW
CBA15	18 SCFM	15 SCFM
CBA25	30 SCFM	25 SCFM
CBA35	42 SCFM	35 SCFM
CBA50	60 SCFM	50 SCFM
CBA75	90 SCFM	75 SCFM
CBA95	114 SCFM	95 SCFM
CBA135	162 SCFM	135 SCFM
CBA205	246 SCFM	205 SCFM
CBA305	366 SCFM	305 SCFM
CBA375	450 SCFM	375 SCFM



Contents

1.0	General Safety Information.....	1
2.0	Receiving, Moving, Unpacking.....	1
3.0	Description	2
4.0	Installation	5
5.0	Controllers – General	9
6.0	Standard Controller	11
7.0	Energy Savings Controller	21
8.0	Operation	37
9.0	Maintenance	41
10.0	Troubleshooting	44
11.0	Notes.....	45
12.0	Replacement Parts	
	Models 15 through 135.....	46, 47
	Models 205 through 375	48, 49
13.0	Maintenance Kits	
	Models 15 through 75.....	50, 51
	Models 95 through 375.....	52, 53
14.0	Drawings	
	P&ID Drawing.....	54
	Electrical Schematic	
	For Mounted Multi-Function Monitor in Hazardous Location.....	56
	WARRANTY	57

▲WARNING

SPX FLOW makes no representation or warranty with respect to this equipment other than (1) it will be free from defects in material and workmanship, (2) will conform to the technical specifications set forth in the product manual included with this equipment and (3) complies with the carbon monoxide and water concentration level requirements of CSA Z180.1-13 Compressed Breathing Air and Systems. THE FOREGOING SET FORTH SPX FLOW'S ENTIRE WARRANTY OBLIGATION AND SPX FLOW MAKES NO OTHER WARRANTY OF ANY KIND WHATSOEVER, AND SPX FLOW EXPRESSLY DISCLAIMS ANY WARRANTIES IMPLIED BY LAW, INCLUDING, BUT NOT LIMITED TO, ANY WARRANTY OF MERCHANTABILITY OR FITNESS FOR A PARTICULAR PURPOSE.

Customer and/or the End User is solely responsible for reviewing all product specifications and other descriptions for the goods included in the Product Manual or otherwise supplied with this equipment and is solely responsible for determining that its use of the equipment (i) is fit, safe, and sufficient for the particular purpose intended by Customer and/or End User and its customers, employees and end-users; and (ii) complies with all applicable laws, regulations, and industry standards, including but not limited to, CSA Z180.1-13 Compressed Breathing Air and Systems, and ISO 8573-1 Air Quality Standard. CUSTOMER AND/OR THE END USER ACKNOWLEDGES AND AGREES THAT IT IS THE EXPERT IN ITS CHOSEN APPLICATION AND USE OF THIS EQUIPMENT, NOT SPX FLOW, AND AS THE EXPERT, THE CUSTOMER AND/OR END USER IS NOT RELYING ON SPX FLOW WITH RESPECT TO ANY OF THE ABOVE.

1.0 General Safety Information

1.1 Pressurized Devices

- This equipment is a pressure-containing device.
- Do not exceed maximum operating pressure as shown on the equipment serial number tag.
- Verify that equipment is fully depressurized before performing service or maintenance functions.

1.2 Electrical

- This equipment requires electricity to operate.
- Install equipment in compliance with national and local electrical codes.
- Standard equipment is supplied with NEMA 4,4X electrical enclosures and is not intended for installation in hazardous environments.
- Disconnect power supply to equipment when performing any electrical service work.

1.3 Breathing Air

- When applied at rated capacity and operating conditions specified within this manual, Breathing Air Purifiers supply air that meet the following standards:
 - Occupational Safety and Health Association (OSHA) CFR 1910.134, Respiratory Protection.
 - Canadian Standards Association (CSA) Z180.1-00, Compressed Breathing Air and Systems.
 - Compressed Gas Association (CGA) Pamphlet G-7, Compressed Air for Human Respiration
 - CGA Pamphlet G-7.1, Commodity Specification for Air.
 - National Fire Protection Association (NFPA) Standard 1500, Fire Department Occupational Safety and Health Program.
 - American National Standards Institute (ANSI) Z88.2-1080, Practices for Respiratory Protection.
- In order to meet the above listed standards, the contaminant concentrations at the purifier outlet must not exceed the limits listed in Table 1.3.1. The concentration levels of other contaminants not listed in Table 1.3.1 are not affected by the Breathing Air Purifier.

1.4 Noise

CAUTION: Do not operate purifier without mufflers installed.

1.5 High Velocity Air

CAUTION: Do not stand near mufflers during tower depressurization.

Contaminant	Maximum Allowable Concentration		Purifier Outlet Concentration at Rated Conditions
	OSHA CFR 1910.134 [1]	CSA Z180.1-00	
Carbon Monoxide (CO) ppm/v	10	5	95% Conversion (i.e. 200 ppm @ inlet = 10 ppm @ outlet)
Carbon Dioxide (CO ₂) ppm/v	1000	500	[2]
Oil (Condensed Hydrocarbons) mg/m ³	5	1	0
Oil Vapor (Gaseous Hydrocarbons) ppm, mL/m ³	N/A	N/A	< .02 [3]
Odor	"lack of noticeable odor"	"no pronounced odor"	None [4]

Table 1.3.1

[1] The OSHA Standard references CGA (Compressed Gas Association) pamphlet G-7.1, Grade D and is generally consistent with those published by ANSI and NFPA.

[2] CO is converted to CO₂ by the purifier and added to the concentration of CO₂ already present (normal atmospheric air contains 314 ppm v/v of CO₂). Although some CO₂ is absorbed in the desiccant beds, high concentrations of CO in the system and/or high concentrations of CO₂ at the compressor intake could result in exceeding allowable CO₂ limits.

[3] Will remove only those gaseous hydrocarbons normally absorbable by activated carbon. Outlet concentration is expressed as methane equivalent. Activated carbon will not remove methane.

[4] Will remove only those odors normally absorbable by activated carbon.

2.0 Receiving, Moving, Unpacking

2.1 Receiving

- This shipment has been thoroughly checked, packed and inspected before leaving our plant.
- It was received in good condition by the carrier and was so acknowledged.
- Check for visible loss or damage. If this shipment shows evidence of loss or damage at time of delivery to you, insist that the carrier's agent make a notation of this loss or damage on the delivery receipt.

2.2 Moving

CAUTION: Use lifting lugs or forklift. Do not lift equipment by piping.

2.3 Unpacking

- Check for concealed loss or damage. When a shipment has been delivered to you in apparent good order, but concealed damage is found upon unpacking, notify the carrier immediately and insist that his agent inspects the shipment.
- Fifteen days from receipt of shipment is the maximum time limit for requesting such inspection.
- Concealed damage claims are not our responsibility as our terms are F.O.B. point of shipment.

3.0 Description

3.1 Prefilters

- Adequate filtration is required upstream of the desiccant dryer and catalytic converter cartridge in order to protect them from contamination. The following filtration, equipped with automatic drains, is installed on all breathing air purifiers.
- Compressed air is first prefiltered through an air line filter where solid particles and high gross liquid concentrations (dust, dirt, water/oil emulsions) are removed.
- The preconditioned air then enters a 99.999% efficient coalescing type oil removal filter which eliminates virtually all submicronic particles, in particular oil mist (aerosols), which protects the desiccant dryer and catalytic converter cartridge from oil contamination.
- Liquids removed in these filters are collected and automatically discharged from the system by automatic drains. The air then passes through a desiccant air dryer where water vapor is removed.

3.2 Desiccant Air Dryer

- The dual tower regenerative desiccant air dryer is an economical and reliable way to dry compressed air to dew points below the freezing point of water (dew points as low as -150°F (101°C) [$1\text{ ppb @}100\text{ psig}$, 7.0 kgf/cm^2] are possible) or reduce the moisture content of compressed air when used in critical process applications.
- The dryer continuously dries compressed air by using two identical towers, each containing a desiccant bed. While one tower is on-stream drying, the other tower is off-stream being regenerated (reactivated, i.e., dried out). The towers are alternated on- and off-stream so that dry desiccant is always in contact with the wet compressed air. In this way a continuous supply of dry air downstream of the dryer is possible.
- The dryer lowers the dew point of compressed air by adsorbing the water vapor present in the compressed air onto the surface of the desiccant. Desiccant is a highly porous solid containing extensive surface area.
- Adsorption occurs until the partial pressure of the water vapor in the air and that on the surface of the desiccant come into equilibrium. As adsorption occurs, heat is released (referred to as the heat of adsorption) and is stored in the bed for use during regeneration.
- Desiccant is regenerated by driving off (desorbing) the water collected on its surface. A pressure-swing (also called a heatless or heater-less because no outside heat is added) dryer regenerates by expanding a portion (approximately 14-15% at 100 psig, 7 kgf/cm^2) of the dried air to atmospheric pressure. This "swing in pressure" causes the expanded air to become very dry (have a very low vapor pressure). This very dry air (called purge air) plus the stored heat of adsorption allows the moisture to desorb from the desiccant. The purge air then carries the desorbed water out of the dryer.
- The removal of water vapor to very low levels is essential in protecting the next purification stage, the removal of carbon monoxide.
- Refer to Section 3.7 for graphical representation of Desiccant Air Dryer Operation.

3.3 Catalytic Converter (CC) Cartridge

- The CC cartridge removes carbon monoxide by converting it to carbon dioxide. CC cartridges are sized to allow for the efficient removal of high concentrations of carbon monoxide.

3.4 Afterfilters

- To ensure downstream air purity the following filtration is installed on all breathing air purifiers.
- Following passage through the CC cartridge, the purified air enters the particulate removal afterfilter which removes 1-micron rust, scale, and other particulates and liquid contaminants from the air stream.
- Finally, the air passes through an oil vapor adsorption filter which removes oil vapor to eliminate objectionable tastes and odors and to protect down-stream components from solid particles 0.01 micron and larger.

3.5 Automatic Purge Saving System

- Featured with the Energy Savings Controller, the Automatic Purge Saving System is designed to save energy (purge air) when pressure-swing dryers are operated at reduced loads.
- The patented Purge Saving System operates by monitoring the changes in temperature within the desiccant beds. These changes in temperature are the result of heat (thermal energy) that is released when a bed is on-line drying (heat of adsorption), and the heat that is used when a bed is off-line being regenerated (heat of desorption). The magnitude of these changes in temperature is an indirect measure of the water vapor content in the air being dried. This information is used to determine the time a tower stays on line during the drying cycle.
- Refer to Section 3.8 for graphical representation of Automatic Purge Saving System.

3.6 Breathing Air Analyzer(s) (Optional)

- Breathing air analyzers measure and display the levels of specified gas concentration and/or dewpoint and provide audible and visual alarms if that measurement exceeds predetermined set points.
- The breathing air purifier can be supplied with any of four possible combinations of air analyzing equipment:
 1. Carbon Monoxide (CO) Monitor.
 2. CO & Oxygen (O_2) Combination Monitor.
 3. CO & Dewpoint Combination Monitor.
 4. CO, & O_2 , and Dewpoint Combination Monitor.
- Refer to analyzer instruction manuals (provided separately) for further details.

3.7 Description of Desiccant Air Dryer Operation

(Refer to Fig. 3-1a.) Compressed air flows through inlet shuttle valve (3) to tower (4A) where the air is dried. After the air is dried it flows through outlet shuttle valve (5) and then to the dryer outlet. A portion of the dry air, the purge stream, branches off from the main air stream prior to the outlet. The purge stream flow rate is controlled by the adjustable purge rate valve (6) and the two purge orifices (7).

The purge flow, which has been throttled to near atmospheric pressure, is directed to tower (4B). As the purge flow passes over the desiccant in tower (4B), it removes the water vapor, which was deposited there while the tower was on-line drying. The purge air then passes through purge and repressurization valve (9B) (normally closed) and purge muffler (10B) to the atmosphere.

After regeneration, purge and repressurization valve (9B) (normally closed) closes allowing tower (4B) to repressurize slowly. Adequate repressurization time is allowed so that tower (4B) is fully repressurized before tower switchover. After a controlled time period, purge and repressurization valve (9A) (normally closed) then opens. This causes the inlet and outlet shuttle valves to shift, directing the air flow through tower (4B).

(Refer to Fig. 3-1b.) Tower (4B) is now drying the main air stream while tower (4A) is being regenerated by the purge air stream. The operation of the purge and repressurization (normally closed) valves is sequenced by the control system located in the electrical enclosure.

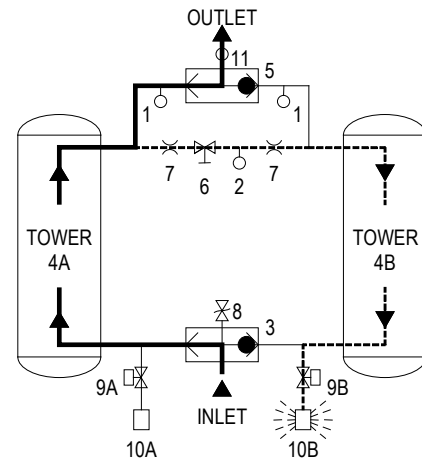

FIGURE 3-1a
TOWER 4A DRYING
TOWER 4B REGENERATING

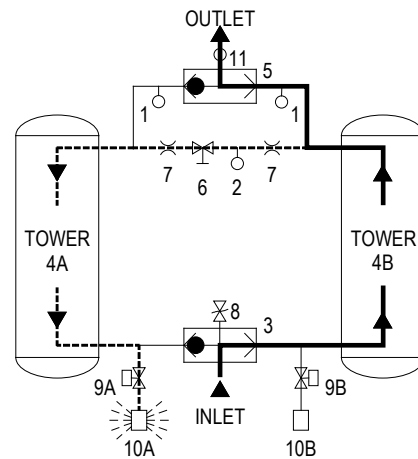

FIGURE 3-1b
TOWER 4A REGENERATING
TOWER 4B DRYING

- | | |
|--------------------------------|--------------------------------------|
| 1. Tower Pressure Gauges | 8. Safety Valve |
| 2. Purge Pressure Gauge | 9. Purge and Repressurization Valves |
| 3. Inlet Shuttle Valve | 10. Purge Mufflers |
| 4. Desiccant Drying Towers | 11. Moisture Indicator |
| 5. Outlet Shuttle Valve | A Left Tower Suffix |
| 6. Adjustable Purge Rate Valve | B Right Tower Suffix |
| 7. Purge Orifices | |

Process Stream —————
Purge Stream - - - - -

3.8 Automatic Purge Saving System

Assume tower 4A is on-line drying while tower 4B has just gone off-line to be regenerated. At the beginning of tower 4B's regeneration cycle a thermistor temperature measurement is made at position B1. After the tower has been regenerated, another measurement is made at B1. The drop in temperature sensed during regeneration is an indirect measure of the water vapor content of the inlet air. The Automatic Purge Saving System's microprocessor then uses this information to calculate an allowable temperature rise in the bed during the drying cycle.

When tower 4B goes back on-line, a temperature probe at position B2 measures the initial bed temperature at this point and then monitors the bed until the calculated temperature rise occurs. The temperature rise occurs as heat of adsorption is released during the drying process. The time for the temperature rise to occur depends on flow rate. At 100% flow the temperature rise takes 5 minutes, at 50% flow it takes 10 minutes.

NOTE: If after 30 minutes, the bed temperature has not risen to the calculated value, the dryer will automatically switch towers.

When the calculated temperature rise is reached, the towers switch with tower 4A now drying and tower 4B being regenerated. Tower 4B regenerates for 3.9 minutes, re-pressurizes, and remains idle until it is called upon for the next drying cycle.

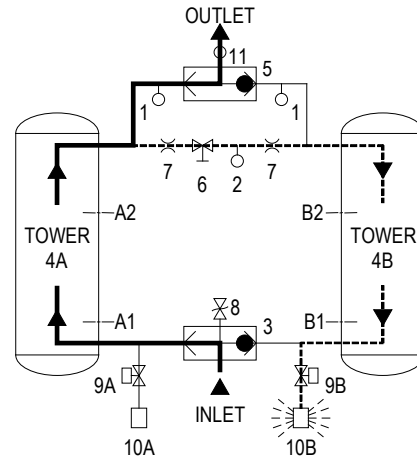

FIGURE 3-4
TOWER 4A DRYING
TOWER 4B REGENERATING

- | | |
|--------------------------------------|--------------------------------------|
| 1. Tower Pressure Gauges | 8. Safety Valve(s) |
| 2. Purge Pressure Gauge | 9. Purge and Repressurization Valves |
| 3. Inlet Shuttle or Switching Valves | 10. Purge Mufflers |
| 4. Desiccant Drying Towers | 11. Moisture Indicator |
| 5. Shuttle or Check Valve(s) | A & C Left Tower Suffix(es) |
| 6. Adjustable Purge Rate Valve | B & D Right Tower Suffix(es) |
| 7. Purge Orifice(s) | |

Process Stream —————
Purge Stream - - - - -

4.0 Installation

4.1 Location in the compressed air system

NOTE: The air compressor should be adequately sized to handle air system demands as well as purge loss. Failure to take this into account could result in overloading air compressors and/or insufficient air supply downstream. It is desirable to install the Breathing Air Purifier where the compressed air is at the lowest possible temperature (downstream of aftercoolers) and the highest possible pressure (upstream of pressure reducing valves) without exceeding the maximum operating pressure of the equipment. (Refer to Figure 4-1)

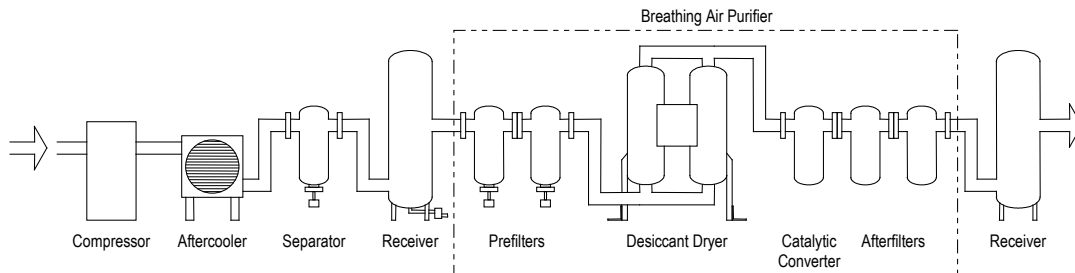

Figure 4-1

4.1.1 Aftercooler/Separator

Compressed air entering the Purifier must be cooled to a temperature of 140°F (60°C) or lower. Use of an aftercooler and condensate separator may be necessary to reduce inlet air temperature to an acceptable level.

NOTE: Installation of a refrigerated dryer ahead of a Breathing Air Purifier does not increase purifier capacity or reduce purge flow requirements.

4.1.2 Breathing Air Purifier

NOTE: By-pass lines are recommended so that maintenance work can be performed without shutting off the air supply.

4.1.3 Receiver(s)

Air receivers dampen pulsations from the compressor discharge line and can eliminate some of the condensed moisture that is carried over from the aftercooler and separator. They also provide a reservoir of stored air for response to system demands in excess of compressor capacity. Size and location of receivers in the compressed air system need to be considered carefully. Flows must not exceed the adjusted maximum inlet capacity of the desiccant air dryer.

4.2 Physical Location

The purifier must be installed with suitable overhead protection as well as clearance to change desiccant. Sufficient clearance around the periphery of the purifier should be provided to allow maintenance personnel access to all areas for routine inspections and adjustments.

4.3 Minimum & Maximum Operating Conditions

The compressed air supply to the purifier inlet should be checked periodically to ensure that purifier design specifications are not exceeded. Normally the compressor installation includes intercoolers, aftercoolers, separators, receivers, or similar equipment, which adequately pretreat the compressed air supply in order to avoid excessively high air temperatures and liquid slugging of downstream equipment.

4.4 Maximum Operating Pressure (MOP)

- 150 psig (10.5 kgf/cm²) is standard.
Refer to Dryer Serial Number Tag.

WARNING: Do not operate the purifier at pressures above the maximum operating pressure shown on the serial number tag.

NOTE: Consult factory for applications requiring higher maximum operating pressures.

4.5 Minimum Operating Pressures

- 60 psig (4.2 kgf/cm²) is the minimum operating pressure.
Refer to Dryer Serial Number Tag.

WARNING: Do not operate the purifier at pressures below the minimum operating pressure shown on the serial number tag.

4.6 Maximum Compressed Air Temperature at Purifier Inlet

- 140°F (60°C) for all models.

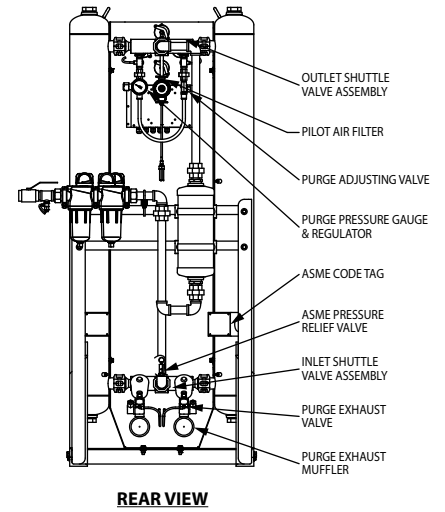
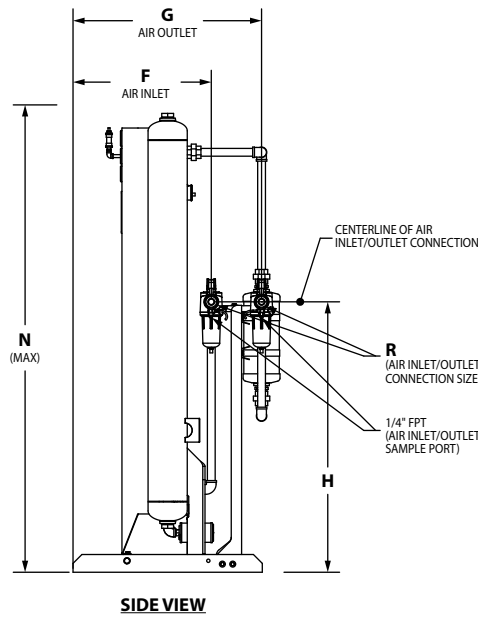
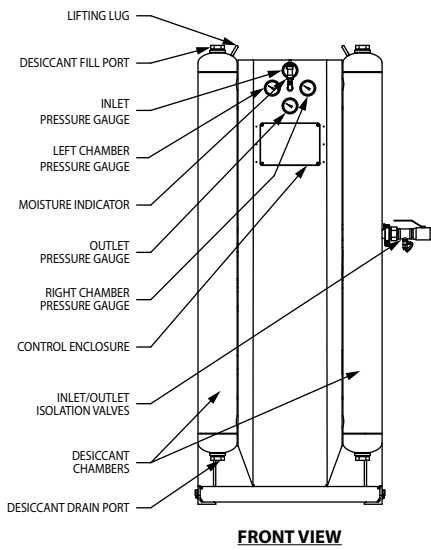
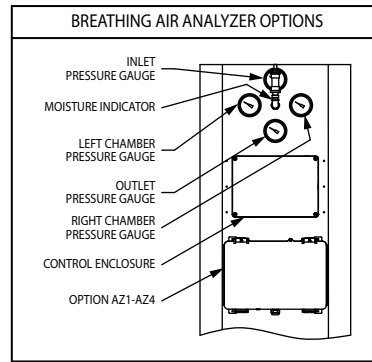
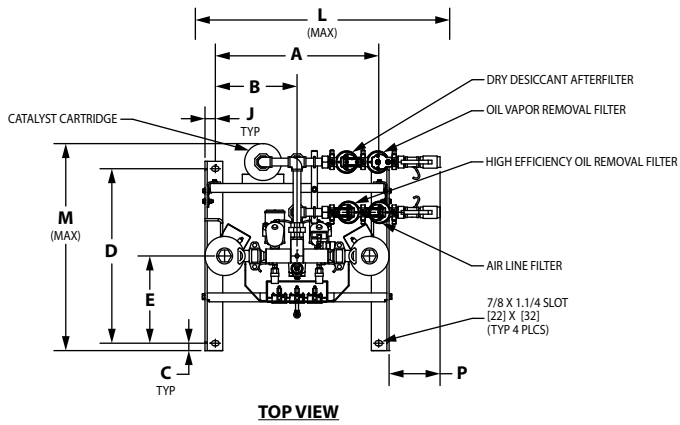

Figure 4-2
(continued on next page)

DIMENSIONS IN INCHES										
MODEL	15	25	35	50	75	95	135	205	305	375
A	27.9/16	27.5/8	27.9/16	27.5/8	27.5/8	38.3/8	38.3/8	41.3/8	49.3/8	49.3/8
B	13.13/16	13.13/16	13.13/16	13.13/16	13.13/16	19.3/16	19.3/16	20.11/16	24.11/16	24.11/16
C	1.1/4	1.1/4	1.1/4	1.1/4	1.1/4	1.1/4	1.1/4	1.1/4	1.1/4	1.1/4
D	29.1/2	29.1/2	29.1/2	29.1/2	29.1/2	35.1/2	35.1/2	35.1/2	35.1/2	35.1/2
E	14.3/4	14.3/4	14.3/4	14.3/4	14.3/4	17.3/4	17.3/4	17.3/4	17.3/4	17.3/4
F	23.3/4	23.3/4	23.3/4	23.3/4	23.3/8	29.5/8	29.5/8	29	32.9/16	32.5/8
G	31.3/4	31.3/4	31.3/4	31.3/4	31.7/8	38.5/8	38.5/8	39.1/8	43.13/16	43.13/16
H	31.1/4	31.1/4	31.1/4	45.1/2	45.3/4	37	37	52.3/8	42.3/8	46.3/8
J	1.3/4	1.3/4	1.3/4	1.3/4	1.3/4	1.3/4	1.3/4	2.3/4	2.3/4	2.3/4
L	42	42	42	43	43	50	53	62	66	67
M	35	35	35	38	35	45	43	45	52	52
N	49	49	49	64	79	56	55	75	65	74
P	7.3/16	7.3/16	7.1/8	8.5/8	8.5/8	4.3/4	7.3/4	10.5/8	7.3/4	7.3/4
R	1 NPT	1 NPT	1 NPT	1 NPT	1 NPT	1 NPT	1 NPT	1.1/2 NPT	2 NPT	2 NPT
WT/LBS	440	450	455	560	700	820	820	1185	1405	1560
DIMENSIONS IN MILLIMETERS										
MODEL	15	25	35	50	75	95	135	205	305	375
A	700	701	700	702	702	975	975	1051	1254	1254
B	351	351	351	351	351	487	487	526	627	627
C	32	32	32	32	32	32	32	32	32	32
D	749	749	749	749	749	902	902	902	902	902
E	375	375	375	375	375	451	451	451	451	451
F	603	603	603	603	594	752	752	737	827	829
G	806	806	806	806	810	981	981	994	1113	1113
H	793	793	793	1155	1161	940	940	1331	1076	1178
J	44	44	44	44	44	44	44	70	70	70
L	1067	1067	1067	1097	1092	1279	1356	1575	1674	1702
M	889	889	889	962	889	1137	1092	1143	1327	1330
N	1244	1244	1244	1615	2007	1433	1396	1905	1650	1871
P	183	183	181	219	219	120	197	269	198	198
R	1 NPT	1 NPT	1 NPT	1 NPT	1 NPT	1 NPT	1 NPT	1.1/2 NPT	2 NPT	2 NPT
WT/KGS	200	205	207	255	319	373	373	538	639	710

Figure 4-2 (continued from previous page)

4.7 Ambient Temperatures

4.7.1 Minimum Ambient Temperature

- Standard units: 35°F (2°C)

4.7.2 Maximum Ambient Temperature

- 120°F (49°C)

NOTE: If the Breathing Air Purifier is installed in ambients below 35°F (2°C), low ambient protection requiring heat tracing and insulation of the prefilter bowls, auto drains and/or sumps, and lower piping with inlet switching and purge/repressurization valves is necessary to prevent condensate from freezing. If installing heat tracing, observe electrical class code requirements for type of duty specified. Purge mufflers and their relief mechanisms must be kept clear from snow and ice buildup that could prevent proper discharge of compressed air.

4.8 Mounting

Install the Breathing Air Purifier on a level pad. Holes are provided in the purifier base members for floor anchors.

NOTE: Floor anchors must be used if area is subject to vibration.

4.9 Piping

Inlet and Outlet connections

Observe locations of inlet and outlet connections as shown in Figure 4-2 and connect inlet and outlet piping as indicated.

NOTE: All piping must be supported so as not to bear on the purifiers or filters.

4.10 Isolation Valves

Breathing air purifiers are pre-installed with inlet and outlet isolation ball valves. Care must be used to ensure that equipment is pressurized slowly. Rapid pressurization could cause excessive pressure drop across filter elements.

4.11 Electrical Connections

All CBA Series dryers, regardless of which controller they are supplied with, will require no more than 35 watts from a single-phase power source for operation.

Refer to the appropriate controller sections for detailed information on connections, ratings, and operation of the Standard or Energy Savings Controllers.

NOTE: Refer to the purifier serial number tag for allowable voltages, frequency and power rating.

4.12 Provisions for Purge Exhaust

- Purge exhaust must be routed through the factory supplied mufflers or piped to a remote location.
- Purge mufflers - If shipped separately, install purge exhaust mufflers in the locations shown in Figure 4-2.
- If purge exhaust is piped to a muffler located in a remote location, choose a combination of diameters, lengths, and turns that limits the additional pressure drop to 1 psid or less.

WARNING: Do not operate purifier without installed mufflers. Exhausting compressed air directly to atmosphere will result in noise levels above OSHA permissible levels and rapidly expanding gas could potentially cause harm to persons or property.

4.13 Initial Desiccant Charge

The purifier is shipped complete with desiccant and is ready to operate after piping and electrical connections are made and controller settings are established.

4.14 Icon Identification

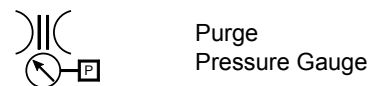

5.0 Controllers – General

5.1 Overview

The solid-state dryer controller is located in a polycarbonate, NEMA Class 4/4X, IP66 rated electrical enclosure mounted to a center panel located between the two desiccant towers. Controls are available in two functional levels. Both the Standard Controller and the Energy Savings Controller offer fixed-time cycles that provide dew points corresponding to ISO compressed air quality class 2. A key difference between the Standard Controller and the Energy Savings Controller is the way in which they address energy savings. When inlet flow is less than the adjusted rated capacity of the dryer, average purge air requirements are reduced. This reduction can translate to energy savings at the air compressor.

Energy Savings Controllers feature the Automatic Purge Saving System (APSS) as described in Sections 3.5 and 3.8. When Energy Savings Controllers are operated in demand rather than fixed cycle modes, the APSS automatically adjusts to dryer loading and extends drying time when possible. Average purge use is thus automatically reduced.

A feature-by-feature comparison of each controller can be found in Table 5-1.

Breathing Air Purifier Controllers		Standard Fixed Cycle Only	Energy Savings Fixed Cycle and APSS
Category	Feature		
General	AC Input Voltage: 85-264 VAC, 47-63 Hz (See Note 1)	•	•
	DC Input Voltage: 11.5-28 VDC (See Note 1)	•	•
	Auxiliary power terminals (See Note 2)	•	•
	Solenoid valve coil voltage	12 VDC	12 VDC
	NEMA 4/4X, IP 66 electrical enclosure rating	•	•
	Soft on/off switch with two power recovery modes (See Note 3)	•	•
	Tower status LEDs (green=drying, amber=regenerating)	•	•
	Process valve status LEDs (on=valve open, off=valve closed)	•	•
	Operating mode LEDs (see next category for number of modes)	•	
	Alarm LED (red)	•	•
	Voltage-free alarm contacts, 5A rating	•	•
	Alarm reset switch (mounted on front panel)	•	•
	Service reminder LEDs (See Note 4)	•	•
Vacuum fluorescent text display		•	
Operating Modes (See NOTE 5)	ISO Class 1 (-100°F/-73°C PDP) - fixed cycle (4 minute)	•	•
	ISO Class 2 (-40°F/-40°C PDP) - fixed cycle (10 minute)	•	•
	ISO Class 2 (-40°F/-40°C PDP) - demand cycle		•
Digital I/O	Controlled shutdown and restart (upon user supplied contact closure)	•	•
	Tower pressure switches (2)	•	•
	High Inlet Temperature Switch		•
	Low Inlet Pressure Switch		•
	High Humidity or Dew Point Alarm		Optional
	Electric drain alarm (1 or 2 filters)		Optional
Analog I/O (12 bit accuracy)	Thermistors (4)		•
	Analog input #1 (0-5 VDC) Dew point transmitter		Optional
	Analog input #2 (0-5 VDC) Pressure transducer		•
	Analog input #3 (0-5 VDC) Temperature sensor		•
Communication	RS232 communication port	•	•

Table 5-1
Feature Comparison
(continued on next page)

Table 5-1 (continued from previous page)

NOTES:

1. The **Standard** and **Energy Savings Controllers** will accept either AC (Alternating Current) or DC (Direct Current) input power.
2. (**Standard & Energy Savings Controllers**) The auxiliary power terminals are in parallel with the input power terminals (i.e., there are two common terminals for each input power connection point, L, N, and PE. The auxiliary power terminals provide a connection point for another device that operates on the same voltage as the Breathing Air Purifier Controller.
3. (**Standard & Energy Savings Controllers**) The controller has two power recovery modes. For **Standard Controllers**, the selection is made using a jumper on the circuit board. For **Energy Savings Controllers**, the selection is made using the switches on the front panel. In one mode, the controller remembers its state (on or off) prior to a power interruption and returns to that state when power is restored. In the other mode, the controller always returns to the off state when power is restored after an interruption.
4. (**Standard & Energy Savings Controllers**) The service reminder LEDs indicate that it is time to perform preventive maintenance on the (a) filters and drains, (b) valves, or (c) desiccant. The user selects between Normal and Severe service intervals. For **Standard Controllers**, the selection is made using a jumper on the circuit board. For **Energy Savings Controllers**, the selection is made using the switches on the front panel.
5. (**Energy Savings Controllers**) The operating mode (fixed or demand cycle) is selected via switches on the front panel.
6. PDP - Pressure Dew Point
MOP - Maximum Operating Pressure

6.0 Standard Controller

This section provides connection, adjustment and operational information for the Standard Control – Fixed Cycle Controller. Similar information for the Energy Savings Controller featuring the APSS, Automatic Purge Saving System, can be found in Section 7.

6.1 Reference Figures

- Figure 6-1, Front Panel Overlay – Standard Controller
- Figure 6-2, Electrical Schematic – Standard Controller
- Figure 6-3, Point-to-Point Diagram – Standard Controller
- Figure 6-4, Panel Layouts – Standard Controller
- Figure 6-5, Enclosure Penetrations – Standard Controller

6.2 Connections

See Figure 6-5, Enclosure Penetrations – Standard Controller for the location, size and function of the various cable and cord connectors that are provided on the bottom of the Standard Controller enclosure.

6.2.1 Connections - Input Power

6.2.1.1 VAC Input Power Connections

Single-phase, alternating current (AC) input power connections ranging from 85-264 VAC and 47 to 63 Hz. can be made at terminals TB5-20, TB5-22, and TB5-24. See reference figures for proper polarity. These terminals are connected to accessory output terminals TB5-21, TB5-23, and TB5-25 respectively. Accessory output terminals can be used to direct power at the same voltage and frequency to external devices.

CAUTION: Accessory output terminals are **NOT** controlled by the power on/off switch and are always energized when power is provided to terminals TB5-20, TB5-22, and TB5-24.

6.2.1.2 VDC Power Connections

- The control and display boards operate on low-voltage direct current. The controller is provided pre-wired with an AC to 12 VDC power supply board. For users with AC power as described in Section 6.2.1.1, their AC input is directed to the power supply board where it is conditioned and returned to the control board as 12 VDC at terminals TB4-18 and –19.
- For users with direct current (DC) input power ranging from 11.5 to 28 VDC, use of the AC to DC power supply board is not needed and their connections can be made at terminals TB4-18 and –19 by first removing the black and red leads coming from the power supply board. See reference figures for proper polarity.

6.2.2 Connections – Common Alarm Contacts

Connections to voltage-free common alarm contacts with a minimum 5-amp rating can be made at terminals TB2-7 through –9.

- Terminal TB2-9 is the common contact connection.
- Terminal TB2-7 is the N.O. (normally open) contact connection.
- Terminal TB2-8 is the N.C. (normally closed) contact connection.
- The alarm relay coil is energized when power is supplied to the controller input terminals and there are no alarms.
- The coil is de-energized when power is removed or when an alarm condition exists.
- The common alarm is designed to activate on: a) either a dryer fault condition or a service reminder, or b) a dryer fault condition only. This is user selectable.
- For the common alarm to activate on either a dryer fault condition or a service reminder, the jumper at J2 is removed. This is the default configuration.

- To have the common alarm activate on a dryer fault condition only, the jumper at J2 is installed.
- Additional information on the common alarm relay logic appears in Table 6-1.

Power To Controller	Controller On or Off?	Alarm or Service Reminder	Alarm Relay Coil	Alarm N.O. Contact (TB2-7)	Alarm N.C. Contact (TB2-8)
No	N/A	N/A	De-Energized	Open	Closed
Yes	Off	N/A	Energized	Closed	Open
Yes	On	No	Energized	Closed	Open
Yes	On	Yes	De-Energized	Open	Closed

Table 6-1
Common Alarm Relay Logic – Standard Controller

6.2.3 Connections – Remote Start / Stop

Terminals TB1-1 and –2 are used to provide a 5 VDC output to a remote switch or volt free contacts that when closed will stop the dryer at the end of the current half cycle. The dryer will resume running at the beginning of the new half cycle when the remote switch or contacts are reopened. When dryer operation is in the remote stop state, all four tower drying (green) and regenerating (amber) LEDs flash simultaneously.

NOTE: Remote start / stop is disabled when the dryer is in the Manual cycle operation mode. When the dryer is in the remote stop state, the only front panel and remote selector switches (see Section 6.2.4) that remain enabled are the power on/off switches.

CAUTION: It is the responsibility of the end-user that, when using this feature, the supply of properly treated breathing air will not be compromised in any way.

6.2.4 Connections – Remote Switches

The controller door is equipped with two momentary-contact, push button switches. Pressing the appropriate icon printed on the display overlay actuates these switches. The display board containing the switches, display LEDs and the J2 terminal strip is mounted on the inside of the enclosure door. The terminal strip provides connection points for remotely mounted, NO (normally open), momentary-contact push buttons that provide the same function as the board mounted switches. The terminal – switch combinations are:

- Terminals J2-1 and J2-2 (unused)
- Terminals J2-3 and J2-4 (unused)
- Terminals J2-5 and J2-6 (remote power on / off switch)

NOTE: Care must be exercised in using this remote switch to stop a dryer. Closing this switch will affect the same response as a loss of power. Both purge-repressurization valves will close. A tower that is actively purging when the power on/off button is actuated will be subjected to a rapid repressurization that can lead to fluidization and subsequent abrasion of the desiccant bed. Ideally, dryers should only be powered off during those portions of the drying cycle when both desiccant towers are at full operating pressure. Use of the remote start/stop connections as described in Section 6.2.3 would be preferable in most cases.

CAUTION: It is the responsibility of the end-user that, when using this feature, the supply of properly treated breathing air will not be compromised in any way.

- Terminals J2-7 and J2-8 (remote alarm reset and manual cycle increment switch)

6.2.5 Connections – RS232

Refer to Figure 6-4, Panel Layouts – Standard Controller. RS232 connections can be made at the 3-pin connector labeled J5 and located at the upper left-hand corner of the control board. A cable for this connection can be purchased through your distributor.

6.3 Control Board Jumpers

Refer to Figure 6-3, Point to Point Connection Diagram – Standard Controller. In the upper left hand corner of the control board there are four two-pin jumpers labeled J1 through J4. The jumper is a removable bridge that is used to make or break continuity between the two pins that form a pair. When installed in the **ON** position, the jumper is placed on both pins of the pair and continuity between the pins is established. When installed in the **OFF** position, the jumper is removed or stored on a single pin and continuity is broken. Jumper functions are as follows:

6.3.1 Jumper J1 – Cycle Times

Jumper J1 is used to select the drying cycle time. Installed in the **OFF** position when the drying cycle time is 10 minutes (-40°F/-40°C PDP). Installed in the **ON** position when the drying cycle time is 4 minutes (-100°F/-73°C PDP).

6.3.2 Jumper J2 – Common Alarm.

Jumper J2 is installed in the **OFF** position to enable both dryer fault alarms and service alarms to activate the common alarm. This is the default configuration. Install jumper J2 in the **ON** position if the common alarm is to be activated by a dryer fault alarm only.

6.3.3 Jumper J3 – Service Reminder Interval

Jumper J3 is used to select the service reminder interval. Installed in the **OFF** position when the Normal service reminder interval is desired. Installed in the **ON** position when the Severe service reminder interval is desired. Service items, check points and time intervals appear in Table 6-2.

6.3.3.1 Filter Service

When the service interval for filters has expired the following LEDs will blink:

- Service LED (amber)
- Two filter LEDs (amber)

6.3.3.2 Desiccant Service

When the service interval for desiccant has expired, the following LEDs will blink:

- Service LED (amber)
- Both tower regenerating LEDs (amber). The service function overrides the normal display of the tower regenerating LEDs.

6.3.3.3 Valve Service

When the service interval for valves has expired, the following LEDs will blink:

- Service LED (amber)
- Valve LEDs (green) The service function overrides the normal display of the valve LEDs.

6.3.3.4 Catalyst Service

When the service interval for catalyst has expired the following LEDs will blink:

- Service LED (amber)
- Catalyst Service LED (amber)

To extinguish the blinking LEDs and restart the timer for a new service interval, press the alarm reset button.

NOTE: Time continues to accumulate as long as power is supplied to the controller, whether the controller is switched on or off.

Use the following sequence to manually reset the accumulated service interval time for all timers.

- Pause for about 1 second at each instruction. If the sequence is executed too quickly it will not work.
- With the controller already on, press and hold the alarm reset button.
- Press and hold the on/off button.
- Release the on/off button.
- Release the alarm reset button. The service interval time is now reset; the maintenance LED flashes three times to acknowledge the action.

Service Item (Customer check points are listed for each item)	Normal Service Interval (J3 OFF)	Severe Service Interval (J3 ON)
Filters 1. Check prefilter Delta-P 2. Ensure prefilter drain is discharging 3. Check afterfilter Delta-P	4,000 Hours	2,000 Hours
Desiccant 1. Check moisture indicator 2. Check dryer outlet dew point 3. Inspect mufflers for excessive dusting	8,000 Hours	4,000 Hours
Valves 1. Ensure valves are cycling properly 2. Check for switching failure alarms 3. Inspect valves for leaks - adjust purge valve as needed	4,000 Hours	2,000 Hours
Catalyst 1. Check moisture indicator 2. Check carbon monoxide concentration at outlet	4,000 Hours	2,000 Hours

Table 6-2
Jumper J3 – Service Reminder Intervals

6.3.4 Jumper J4 – Power Recovery Mode

Jumper J4 is used to select the power recovery mode. When power to the controller is interrupted, the position of this jumper controls the recovery mode of the dryer when power is restored. Installed in the **OFF** position when automatic power recovery is **not** desired. Installed in the **ON** position when automatic power recovery is desired.

- Jumper J4 installed in the **OFF** position – Automatic power recovery is turned off. The controller returns to the off state when interrupted power to the controller is restored.
- Jumper J4 installed in the **ON** position – Automatic power recovery is turned on. The controller remembers its state (on or off) prior to a power interruption and returns to that state (at the beginning of the prior ISO operating cycle) when power is restored. If power is interrupted while the controller is in the Manual cycle mode, the controller will return to the prior ISO operating cycle and not the Manual cycle when power is restored.

6.4 Front Panel Overlay

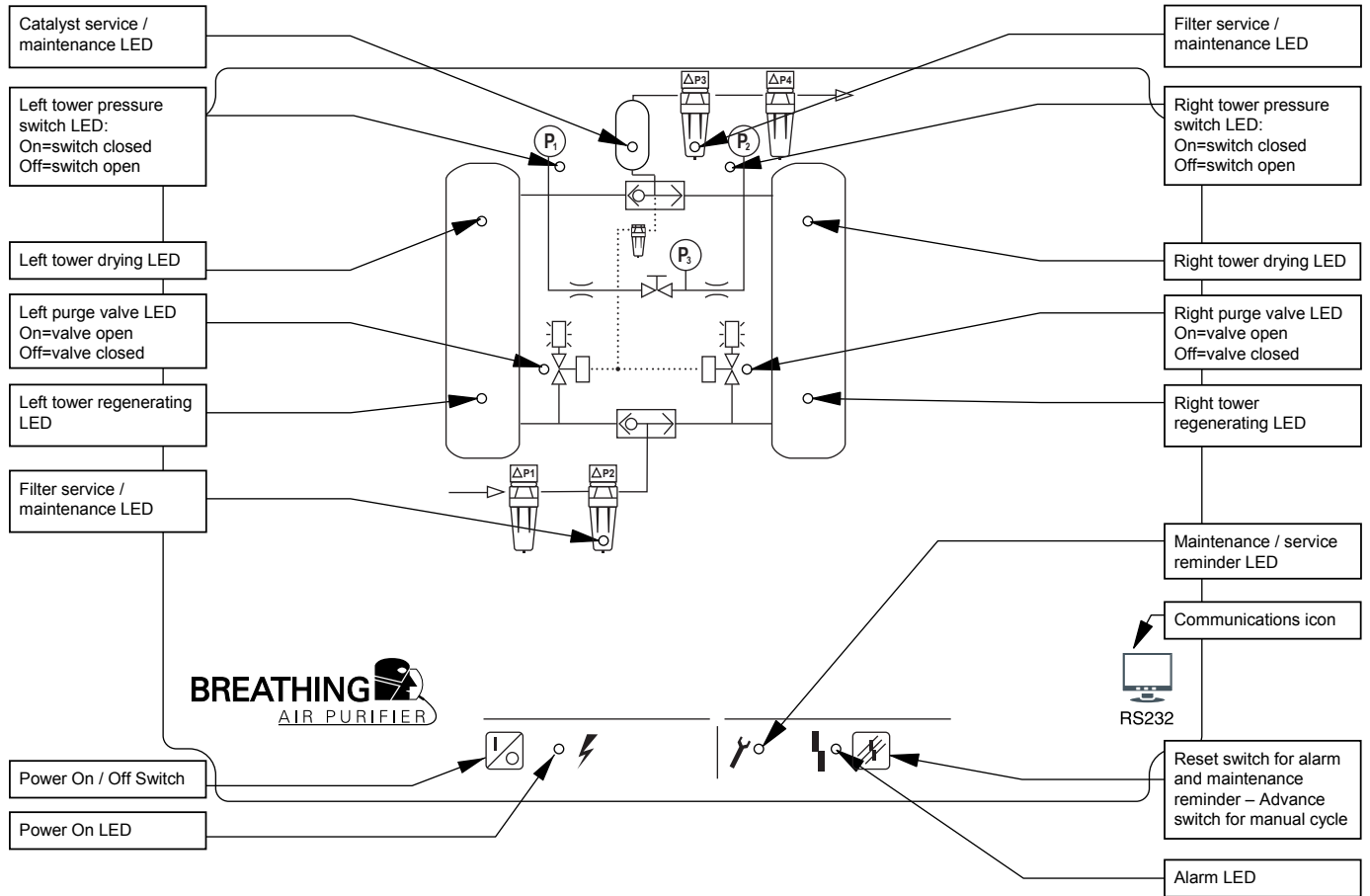

Figure 6-1
Front Panel Overlay – Standard Controller

6.4.1 Front Panel LEDs

- Power on - green
- Alarm – red
- Service / maintenance reminder – amber
- Filters (pre, after) and catalytic converter cartridge service / maintenance reminders - amber
- Purge / repressurization valve status (On = valve open; Off = valve closed) – green
- Left and right tower status (regenerating) - amber
- Left and right tower status (drying) - green
- Left and right tower pressure switch status (On = switch closed; Off = switch open) - green

6.4.2 Front Panel Switches

The front panel contains two momentary-contact push button switches. Refer to Figure 6-1, Front Panel Overlay – Standard Controller for the appropriate icon associated with each switch. Pushing on the overlay icon actuates the switch. Switching can be affected remotely by wiring external pushbuttons to the J2 terminals located on the rear of the display board. Refer to Section 6.2.4.

6.4.2.1 Purifier On / Off Switch

This switch is used to turn the Purifier on (run) or off (stop).

CAUTION: In the event of a loss of power, either intentional or unintentional, both purge-repressurization valves will close. A tower that is actively purging when the power off button is actuated will be subjected to a rapid repressurization that can lead to fluidization and subsequent abrasion of the desiccant bed. Ideally, dryers should be powered off at the end of any half cycle when both desiccant towers are at full operating pressure.

Power recovery after an external loss of power is affected by the position of control board jumper J4 (power recovery mode). Refer to Section 6.3.4 for additional information.

6.4.2.2 Reset Switch

- This switch is normally used to reset an alarm or service reminder.

6.4.3 Switching Failure Alarms

- When a tower does not de-pressurize, the Alarm LED, Pressure Switch LED, and Tower Regenerating LED will blink.
- When a tower does not re-pressurize, the Alarm LED, Pressure Switch LED, and Tower Drying LED will blink.
- To extinguish the blinking LEDs, correct the fault condition and press the alarm-reset button.
- Refer to Table 6-4.

6.5 Fixed Cycle Timing

Refer to Table 6-3 for the fixed cycle timing for the Standard Controller.

6.6 Event Sequence and Component Status

Refer to Table 6-4 for the event sequence and component status for the Standard Controller.

Dryer MOP	60-150 psig	
ISO Class	1	2
Dew Point	-73°C	-40°C
	-100°F	-40°F
Cycle Time (minutes)	4	10
Time	Time from start of cycle (minutes : seconds)	
t0	00:00	00:00
t1	00:02	00:02
t2	00:06	00:06
t3	01:12	04:00
t4	02:00	05:00
t5	02:02	05:02
t6	02:06	05:06
t7	03:12	09:00
t8	04:00	10:00
Reference Data		
Purge time (min:sec)	01:06	03:54
Purge time (min:sec)	00:48	01:00

Table 6-3
Fixed Cycle Timing – Standard Controller

Process valve name (Process valve state w/ de-energized pilot solenoid valve)	Time (refer to Table 6-3)									
	t0	t1	t2	t3	t4	t5	t6	t7	t8	
	Left Tower Drying Right Tower Regenerating Half Cycle					Right Tower Drying Left Tower Regenerating Half Cycle				
Left purge valve (normally closed)								Pilot Energized (open)		
Right purge valve (normally closed)			Pilot Energized (open)							
Normal status of pressure switches										
Left tower pressure switch	closed	closed	closed	closed	closed	closed	closed	closed for < 5 sec. then open	open at t7, closed before t8	
Right tower pressure switch	closed	closed	closed for < 5 sec. then open	open at t3, closed before t4	closed	closed	closed	closed	closed	
Pressure switch status that causes an alarm										
Left tower drying Low tower pressure ^a			open ¹	open ¹						
Left tower regenerating Fail to de-pressurize ^b								closed ¹		
Left tower regenerating Fail to re-pressurize ^c										open ²
Right tower drying Low tower pressure ^d								open ¹	open ¹	
Right tower regenerating Fail to de-pressurize ^e			closed ¹							
Right tower regenerating Fail to re-pressurize ^f					open ²					
NOTE	Stop cycle on fault	Comments								
1: Check for fault condition at 15, 25, 35,... seconds into half-cycle	no	If the fault condition is clear for 2 cycles: the alarm LED stays on (without blinking); the tower and pressure switch LEDs stop blinking (return to normal operation). Once the fault condition is clear, pressing the reset button will clear the alarm LED (and the tower and pressure switch LEDs if they are still blinking).								
2: Check for fault condition just before the end of the half-cycle	yes	If the fault condition clears: resume cycling; the alarm LED stays on (without blinking); the pressure switch LED stops blinking (returns to normal operation). Once the fault condition is clear, pressing the reset button will clear the alarm LED.								
a: Blink the following LEDs: Alarm + P1 + Left tower drying										
b: Blink the following LEDs: Alarm + P1 + Left tower regenerating										
c: Blink the following LEDs: Alarm + P1										
d: Blink the following LEDs: Alarm + P2 + Right tower drying										
e: Blink the following LEDs: Alarm + P2 + Right tower regenerating										
f: Blink the following LEDs: Alarm + P2										

Table 6-4
Event Sequence and Component Status – Standard Controller

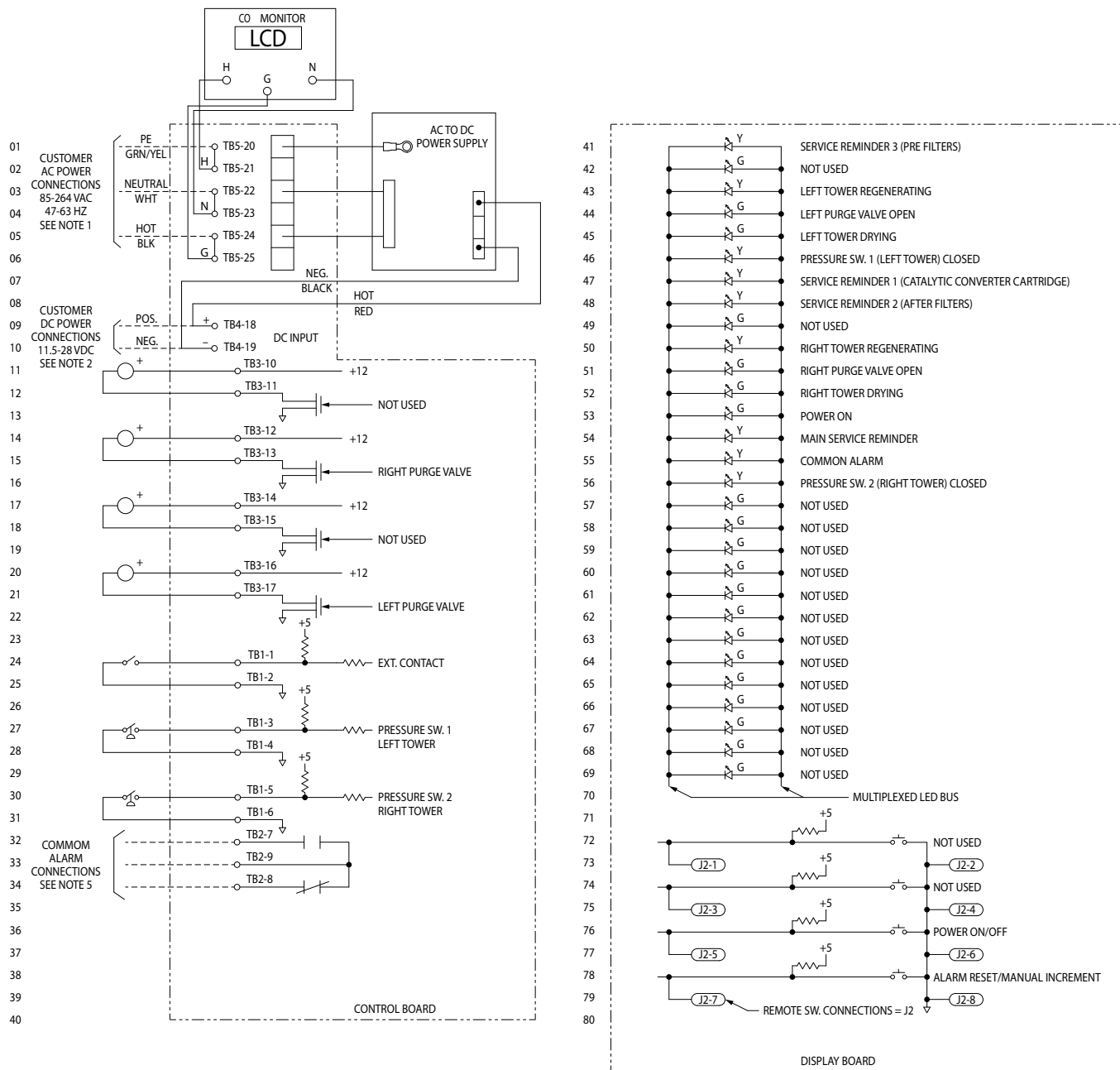

NOTES:

- CUSTOMER POWER CONNECTIONS WHEN SUPPLY VOLTAGE IS AC (ALTERNATING CURRENT). TERMINALS TB5-21, TB5-23 AND TB5-25 CAN BE USED TO PROVIDE ACCESSORY POWER AT THE SAME VOLTAGE AND FREQUENCY. AC POWER IS DIRECTED TO POWER SUPPLY BOARD WHERE IT IS CONVERTED TO 12 VDC AND RETURNED TO THE CONTROL BOARD.
- CUSTOMER POWER CONNECTIONS WHEN SUPPLY VOLTAGE IS DC (DIRECT CURRENT). RED AND BLACK WIRES FROM THE POWER SUPPLY BOARD SHOULD BE REMOVED AND THE CUSTOMER SHOULD MAKE THEIR POWER CONNECTIONS AT TERMINALS TB4-18 AND TB4-19.
- VOLTAGE RATING OF VALVES IS 12 VDC.
- VOLTAGE RATING OF SWITCHES IS 5 VDC.
- WITH UNIT ON AND NO ALARMS, THERE SHOULD BE CONTINUITY BETWEEN TERMINALS TB2-7 AND TB2-9. DRY CONTACTS RATED AT 250VAC/5A (MAX.) OR 24VDC/2A (MAX.).

Figure 6-2
Electrical Schematic – Standard Controller

JUMPERS

(SEE NOTE 3)

JUMPER NO. & FUNCTION	JUMPER OFF	JUMPER ON
J1 - CYCLE TIMES	10 MINUTE	4 MINUTE
J2 - COMMON ALARM	DEFAULT	ACTIVATED BY DRYER FAULT ALARM ONLY
J3 - SERVICE INTERVAL	NORMAL	SEVERE
J4 - POWER RECOVERY MODE	OFF	AUTO

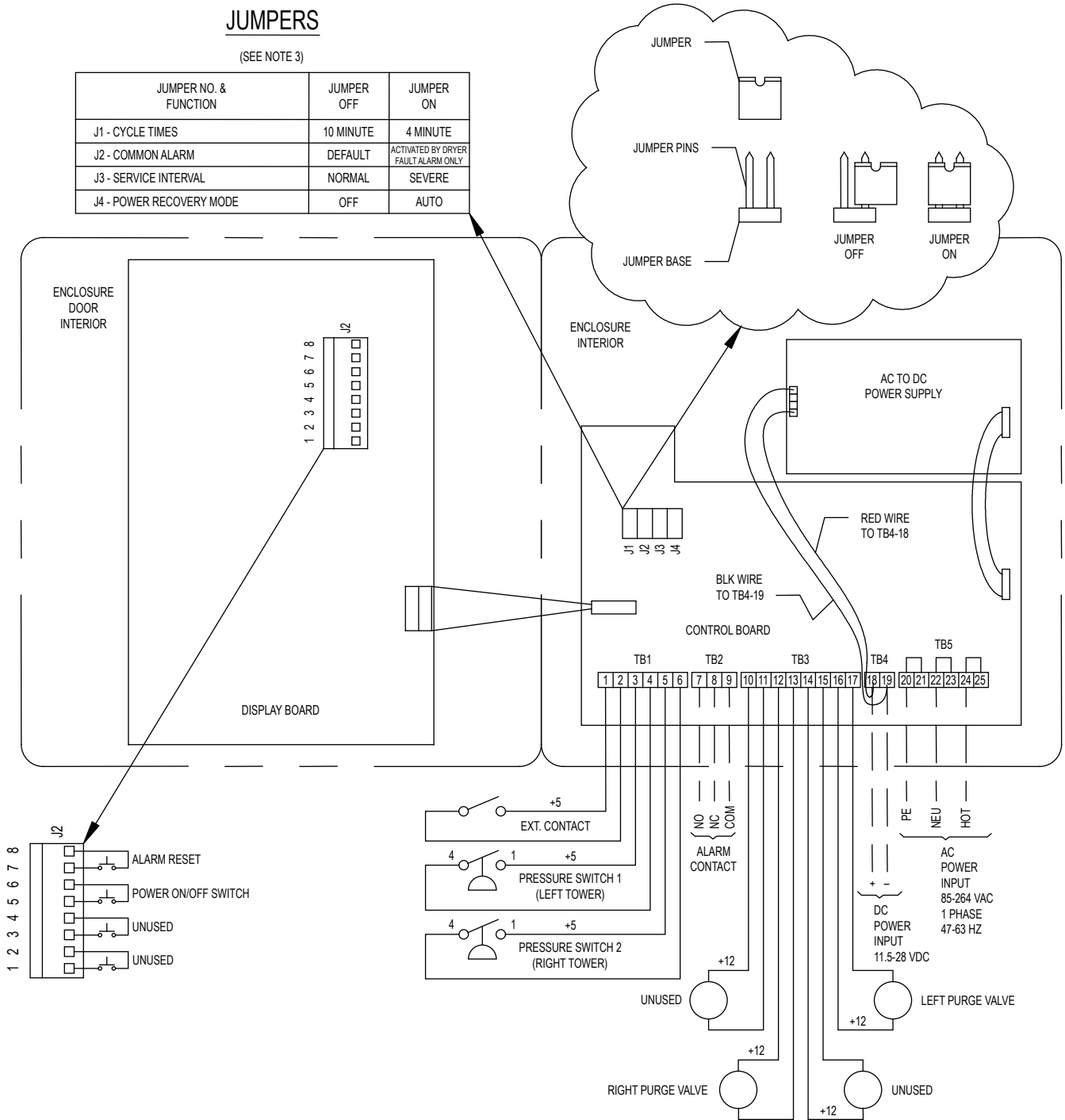

NOTES:

- SEE FIGURE 6-5 FOR RECOMMENDED AWG CONDUCTOR SIZES.
- CUSTOMER SUPPLIED AC (ALTERNATING CURRENT) INPUT POWER CONNECTIONS SHOULD BE MADE AT TERMINALS TB5-21, TB5-23, AND TB5-25. FOR CUSTOMER SUPPLIED DC (DIRECT CURRENT) POWER, THE RED AND BLACK WIRES FROM THE POWER SUPPLY BOARD SHOULD BE REMOVED AND THE CUSTOMER POWER CONNECTIONS SHOULD BE MADE AT TERMINALS TB4-18 AND TB4-19.
- IN THE "JUMPER OFF" POSITION, THE JUMPER CAN BE COMPLETELY REMOVED OR STORED ON A SINGLE PIN. IN THE "JUMPER ON" POSITION, THE JUMPER IS INSTALLED ACROSS BOTH PINS TO PROVIDE CONTINUITY.
- WITH THE UNIT ON AND NO ALARMS, THERE SHOULD BE CONTINUITY BETWEEN TERMINALS TB2-7 AND TB2-9.

Figure 6-3
Point-to-Point Connection Diagram – Standard Controller

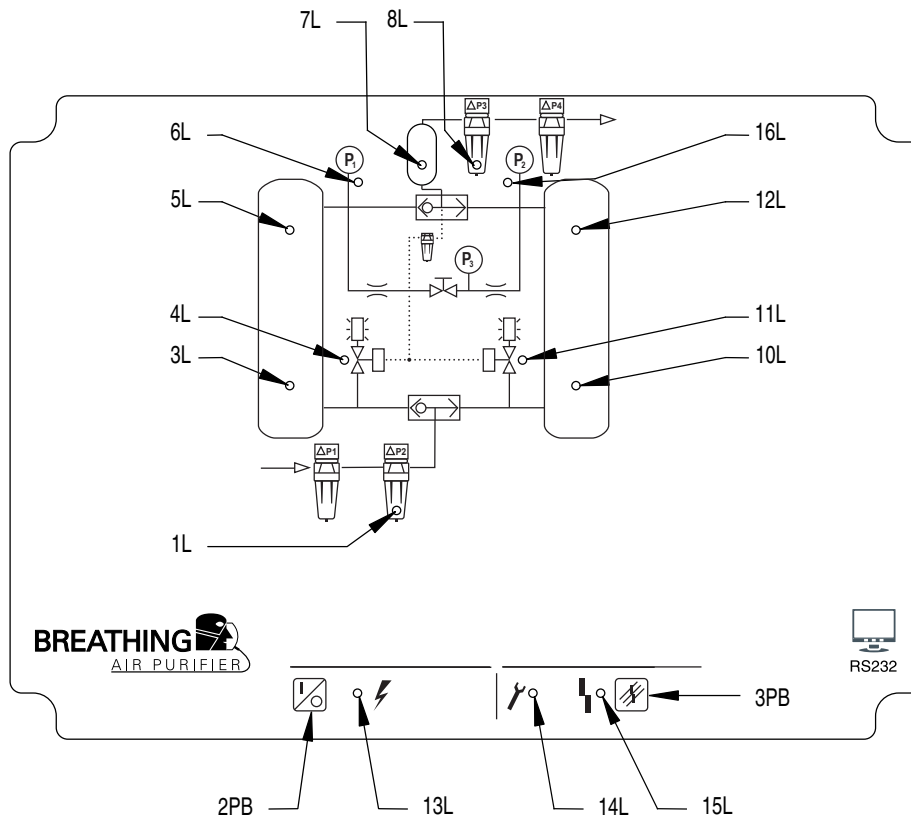

ENCLOSURE DOOR EXTERIOR

LEGEND

CR	COMMON ALARM RELAY	11L	RIGHT PURGE VALVE OPEN (GREEN)	2PB	POWER ON/OFF SWITCH
1L	SERVICE REMINDER 3 - PREFILTERS (AMBER)	12L	RIGHT TWR. DRYING (GREEN)	3PB	ALARM RESET/MANUAL CYCLE INCREMENT SWITCH
3L	LEFT TOWER REGEN. (AMBER)	13L	POWER ON LED (GREEN)	RS232	SERIAL I/O CONNECTION
4L	LEFT PURGE VALVE OPEN (GREEN)	14L	MAIN SERVICE REMINDER (AMBER)	PS	AC TO DC POWER SUPPLY
5L	LEFT TOWER DRYING (GREEN)	15L	COMMON ALARM (RED)	J2	REMOTE SWITCH TERMINALS
6L	PRESS. SWITCH 1 - L. TWR. CLOSED (GREEN)	16L	PRESS. SWITCH 2 - R. TWR. CLOSED (GREEN)	TB1	EXTERNAL CONTROL INPUT TERMINALS
7L	SERVICE REMINDER 1 - CATALYTIC CONVERTER CARTRIDGE (AMBER)	CNTRLPCB	CONTROL BOARD	TB2	COMMON ALARM CONTACT TERMINALS
8L	SERVICE REMINDER 2 - AFTERFILTERS (AMBER)	DISPCB	DISPLAY BOARD	TB3	VALVE OUTPUT TERMINALS
10L	R. TWR REGEN. (AMBER)	JMP	CONFIGURATION JUMPERS (MAX. OPER. PRESS., SERVICE INTERVAL, & POWER RECOVERY MODE)	TB4	DC POWER INPUT TERMINALS
				TB5	AC POWER INPUT TERMINALS

Figure 6-4
Panel Layouts – Standard Controller
 (continued on next page)

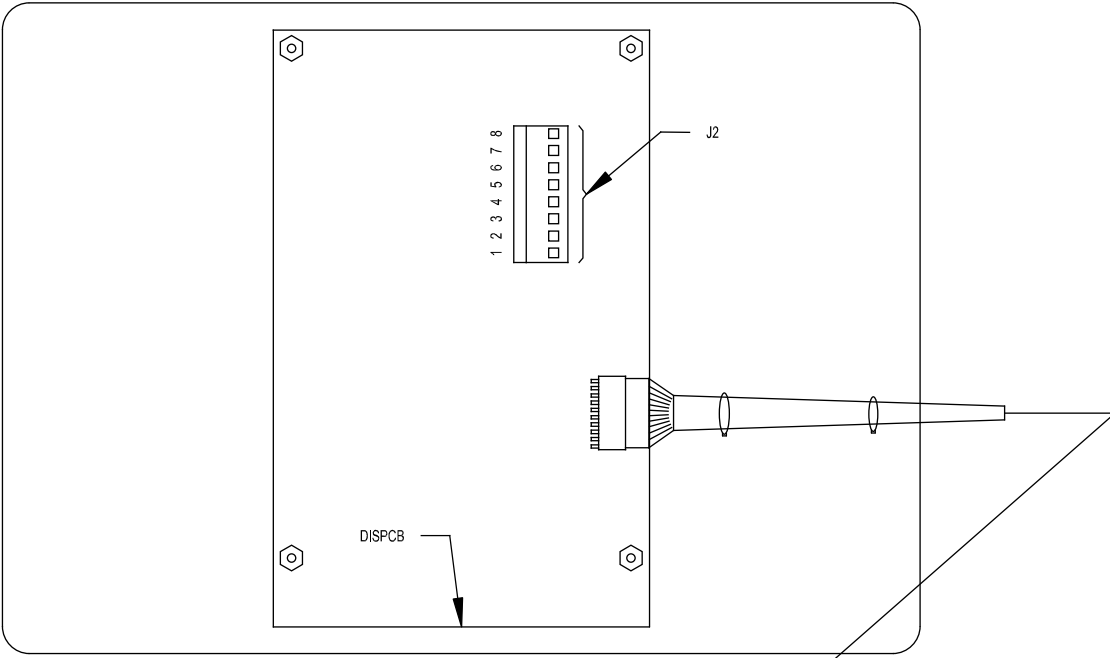

ENCLOSURE DOOR INTERIOR

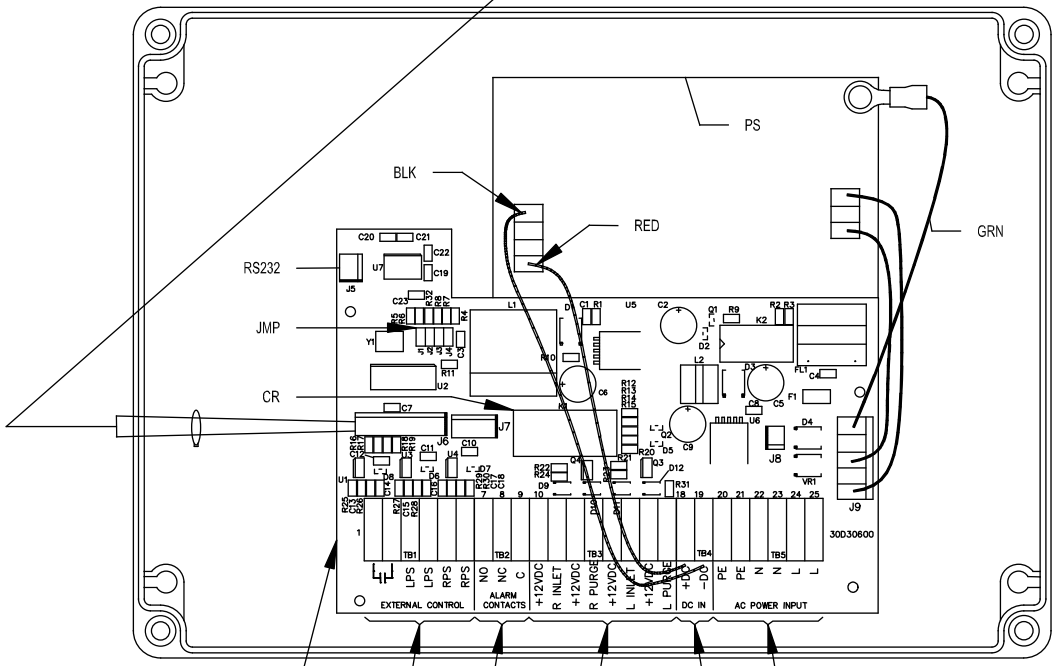

CTRLPCB TB1 TB2 TB3 TB4 TB5
11.5-28 VDC 85-264 VAC 47-63 HZ

ENCLOSURE INTERIOR

**Figure 6-4
Panel Layouts – Standard Controller
(continued from previous page)**

LOCATION	FUNCTION		# OF CONDUCTORS	AWG SIZE	CABLE DIAMETER RANGE				CONNECTOR SIZE	ENCLOSURE HOLE DIA.	
					MIN. DIA.		MAX. DIA.			in.	mm
					in.	mm	in.	mm			
1	FACTORY CONNECTIONS STANDARD DEVICES	PRESSURE SWITCH - RIGHT TOWER	2	18	0.181	4.6	0.312	7.9	PG-9	0.599	15.2
2		PRESSURE SWITCH - LEFT TOWER	2	18	0.181	4.6	0.312	7.9	PG-9	0.599	15.2
3		SOLENOID - LEFT PURGE VALVE	2	18	0.181	4.6	0.312	7.9	PG-9	0.599	15.2
4		SOLENOID - RIGHT PURGE VALVE	2	18	0.181	4.6	0.312	7.9	PG-9	0.599	15.2
5	USER CONNECTIONS	ALARM CONTACTS	2	16	0.181	4.6	0.312	7.9	PG-9	0.599	15.2
6		REMOTE STOP / START	2	16	0.181	4.6	0.312	7.9	PG-9	0.599	15.2
7		RS232	3	22	0.114	2.9	0.250	6.4	PG-7	0.492	12.5
8		INPUT POWER	3	14	0.230	5.8	0.395	10.0	PG-11	0.733	18.6

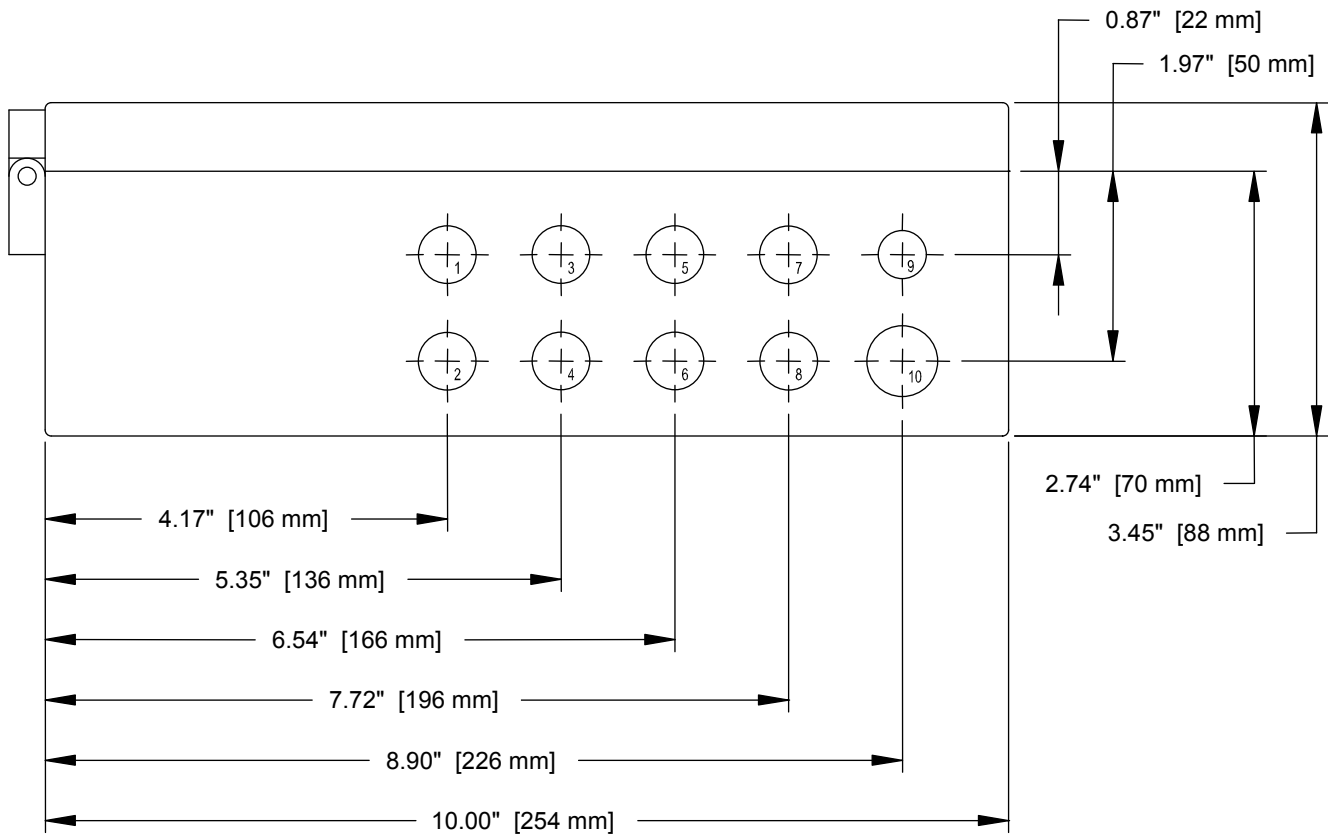

BOTTOM VIEW - HINGE LEFT

**Figure 6-5
Enclosure Penetrations – Standard Controller**

7.0 Energy Savings Controller

This section provides connection, adjustment and operational information for the Energy Savings Controller featuring the Automatic Purge Saving System (APSS). Similar information can be found in Section 6 for the Standard Control – Fixed Cycle Controller.

7.1 Reference Figures

- Figure 7-1, Front Panel Overlay – Energy Savings Controller
- Figure 7-2, Electrical Schematic – Energy Savings Controller
- Figure 7-3, Point-to-Point Diagram – Energy Savings Controller
- Figure 7-4, Panel Layouts – Energy Savings Controller
- Figure 7-5, Enclosure Penetrations – Energy Savings Controller

7.2 Connections

See Figure 7-5, Enclosure Penetrations – Energy Savings Controller for the location, size and function of the various cable and cord connectors that are provided on the bottom of the Energy Savings Controller enclosure.

7.2.1 Connections - Input Power

7.2.1.1 VAC Input Power Connections

Single-phase, alternating current (AC) input power connections ranging from 85-264 VAC and 47 to 63 Hz. can be made at terminals TB6-45, TB6-47, and TB6-49. See reference figures for proper polarity. These terminals are connected to accessory output terminals TB6-44, TB6-46, and TB6-48 respectively. Accessory output terminals can be used to direct power at the same voltage and frequency to external devices.

CAUTION: Accessory output terminals are **NOT** controlled by the power on/off switch and are always energized when power is provided to terminals TB6-45, TB6-47, and TB6-49.

7.2.1.2 VDC Power Connections

- The control and display boards operate on low-voltage direct current. The controller is provided pre-wired with an AC to 12 VDC power supply board. For users with AC power as described in Section 7.2.1.1, their AC input is directed to the power supply board where it is conditioned and returned to the control board as 12 VDC at terminals TB5-42 and TB5-43.
- For users with direct current (DC) input power ranging from 11.5 to 28 VDC, use of the AC to DC power supply board is not needed and their connections can be made at terminals TB5-42 and TB5-43 by first removing the black and red leads coming from the power supply board. See reference figures for proper polarity.

7.2.2 Connections – Common Alarm Contacts

Connections to voltage-free common alarm contacts with a minimum 5-amp rating can be made at terminals TB4-39 through -41.

- Terminal TB4-41 is the common contact connection.
- Terminal TB4-39 is the N.O. (normally open) contact connection.
- Terminal TB4-40 is the N.C. (normally closed) contact connection.
- The alarm relay coil is energized when power is supplied to the controller input terminals and there are no alarms.
- The coil is de-energized when power is removed or when an alarm condition exists.
- The common alarm is designed to activate on: a) either a dryer fault condition or a service reminder, or b) a dryer fault condition only. This is user selectable.
- For the common alarm to activate on either a dryer fault condition or a service reminder, the jumper at JP6 is removed. This is the default configuration.

- To have the common alarm activate on a dryer fault condition only, the jumper at JP6 is installed.
- Additional information on the common alarm relay logic appears in Table 7-1.

Power To Controller?	Controller On or Off?	Alarm or Service Reminder	Alarm Relay Coil	Alarm N.O. Contact (TB4-39)	Alarm N.C. Contact (TB4-40)
No	N/A	N/A	De-Energized	Open	Closed
Yes	Off	N/A	Energized	Closed	Open
Yes	On	No	Energized	Closed	Open
Yes	On	Yes	De-Energized	Open	Closed

Table 7-1
Common Alarm Relay Logic – Energy Savings Controller

7.2.3 Connections – Remote Start / Stop

Terminals TB2-17 and TB2-18 are used to provide a 5 VDC output to a remote switch or volt free contacts that when closed will stop the dryer at the end of the current half cycle. The dryer will resume running at the beginning of the new half cycle when the remote switch or contacts are reopened. When dryer operation is in the remote stop state, all four tower drying (green) and regenerating (amber) LEDs flash simultaneously.

NOTE: Remote start / stop is disabled when the dryer is in the Manual cycle operation mode. When the dryer is in the remote stop state, the only front panel and remote selector switches (see Section 7.2.4) that remain enabled are the power on/off switches.

CAUTION: It is the responsibility of the end-user that, when using this feature, the supply of properly treated breathing air will not be compromised in any way.

7.2.4 Connections – Remote Switches

The controller door is equipped with four momentary-contact, push button switches. Pressing on the appropriate icon printed on the display overlay actuates these switches. The display board containing the switches, display LEDs, text display, and the RPB (J2) terminal strip is mounted on the inside of the enclosure door. The terminal strip provides connection points for remotely mounted, NO (normally open), momentary-contact push buttons that provide the same function as the board mounted switches. The terminal – switch combinations are:

- Terminals J2-1 and J2-2 (Remote “SELECT” switch)
- Terminals J2-3 and J2-4 (Remote “ENTER” switch)
- Terminals J2-5 and J2-6 (Remote Power On / Off Switch)

NOTE: Care must be exercised in using this remote switch to stop a dryer. Closing this switch will affect the same response as a loss of power. Both purge-repressurization valves will close. A tower that is actively purging when the power on/off button is actuated will be subjected to a rapid repressurization that can lead to fluidization and subsequent abrasion of the desiccant bed. Ideally, dryers should only be powered off during those portions of the drying cycle when both desiccant towers are at full operating pressure. Use of the remote start/stop connections as described in Section 7.2.3 would be preferable in most cases.

CAUTION: It is the responsibility of the end-user that, when using this feature, the supply of properly treated breathing air will not be compromised in any way.

- Terminals J2-7 and J2-8 (Remote Alarm Reset Switch)

7.2.5 Connections – RS232

Refer to Figure 7-4, Panel Layouts – Energy Savings Controller. RS232 connections can be made at the 3-pin connector labeled J3 and located at the upper left-hand corner of the control board. A cable for this connection can be purchased through your distributor.

7.3 Control Board Jumpers

Refer to Figure 7-3, Point to Point Connection Diagram – Energy Savings Controller. In the upper left hand corner of the control board there are eight two-pin jumpers labeled JP1 through JP8. Only two of the eight jumper pairs are utilized. Jumper pair J1 and jumper pairs JP3-JP5 and JP7-JP8 are not used.

NOTE: Do not install jumpers in the **ON** position on jumper pair J1 and jumper pairs JP3-JP5 and JP7-JP8.

The jumper is a removable bridge that is used to make or break continuity between the two pins that form a pair. When installed in the **ON** position, the jumper is placed on both pins of the pair and continuity between the pins is established. When installed in the **OFF** position, the jumper is removed or stored on a single pin and continuity is broken. Jumper functions are as follows:

7.3.1 Jumper JP1 – Unused

7.3.2 Jumper JP2 – Electric Drains

- Jumper JP2 is installed in the **ON** position if one or two electric demand drains are installed. It is installed in the **OFF** position when no electric drains are installed.
- The drains can be manually tested through the Energy Savings Controller Setup Mode.
- The drains provide a digital alarm signal to the Energy Savings Controller, which then displays an alarm message.
- If the dryer has only 1 drain, then the alarm input terminals for Drain 2 (TB2-25 and TB2-26) must be shorted.

7.3.3 Jumpers JP3 through JP5 – Unused.

7.3.4 Jumper JP6 – Common Alarm.

Jumper JP6 is installed in the **OFF** position to enable both dryer fault alarms and service alarms to activate the common alarm. This is the default configuration. Install jumper JP6 in the **ON** position if the common alarm is to be activated by a dryer fault alarm only.

7.3.5 Jumpers JP7 through JP8 – Unused.

7.4 Front Panel Overlay

Refer to Figure 7-1, Front Panel Overlay – Energy Savings Controller for information regarding the location and function of the LEDs, switches, and text display.

7.4.1 Front Panel LEDs

- Power on – green (constant when controller is switched on; flashing when controller is energized but switched off.)
- Alarm – red
- Service / maintenance reminder – amber
- Filters (pre, after) and catalytic converter cartridge service / maintenance reminders - amber
- Purge / repressurization valve status (On = valve open; Off = valve closed) – green
- Left and right tower status (regenerating) - amber
- Left and right tower status (drying) - green
- Left and right tower pressure switch status (On = switch closed; Off = switch open) – green

7.4.2 Front Panel Switches

The front panel contains four momentary-contact push button switches. Refer to Figure 7-1, Front panel Overlay – Energy Savings Controller for the appropriate icon associated with each switch. Pushing on the overlay icon actuates the switch. Switching can be affected remotely by wiring external pushbuttons to the RPB (J2) terminals located on the rear of the display board. Refer to Section 7.2.4.

7.4.2.1 Purifier On / Off Switch

This switch is used to turn the Purifier on (run) or off (stop).

CAUTION: In the event of a loss of power, either intentional or unintentional, both purge-repressurization valves will close. A tower that is actively purging when the power off button is actuated will be subjected to a rapid repressurization that can lead to fluidization and subsequent abrasion of the desiccant bed. Ideally, dryers should be powered off at the end of any half cycle when both desiccant towers are at full operating pressure.

Power recovery after an external loss of power is affected by the programming of the auto restart mode (Program Mode – Screen 2). Refer to Section 7.7 for additional information.

7.4.2.2 SELECT Switch

This button is located to the left of the text display window. Refer to Section 7.6 for additional information.

7.4.2.3 ENTER Switch

This button is located to the right of the text display window. Refer to Section 7.6 for additional information.

7.4.2.4 Alarm Reset Switch

This switch is normally used to reset an alarm or service reminder. Refer to Section 7.9 for additional information.





7.5 Event Sequence and Component Status

Refer to Tables 7-2, 7-4, and 7-5 for the event sequence, timing and component status for the Energy Savings Controller.

7.6 Front Panel Operation

1. There are five operating modes for the Energy Savings Controller.
 - a. Program Mode
 - b. Setup Mode
 - c. Alarm & Service Mode
 - d. Display Mode
 - e. Test Mode
2. Each mode is described below.

7.7 Program Mode

1. Press and hold  and  simultaneously for 3 seconds to enter Program Mode.
2. Program Mode is comprised of the screens that are described below.
3. There are three ways to exit Program Mode.
 - a. Press  after making the selection in the final screen.
 - b. At any screen, press and hold  for 3 seconds.
 - c. The controller automatically exits Program Mode if no button is pressed within 60 seconds.
4. Upon exiting Program Mode the controller will switch to Display Mode.

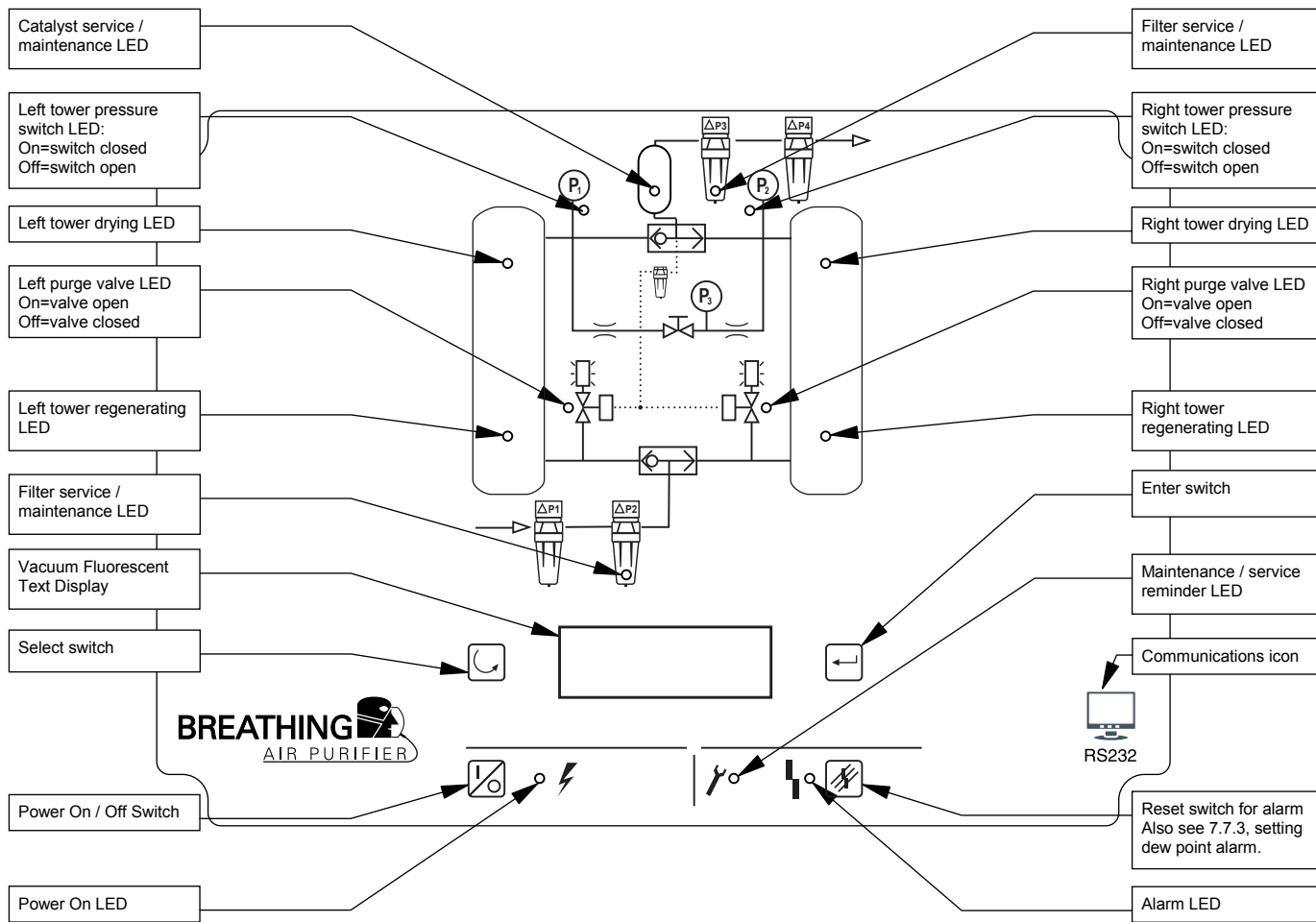
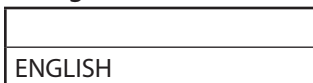

Figure 7-1
Front Panel Overlay – Energy Savings Controller

7.7.1 Program Mode Screen 1 – Select the language.



- Press to scroll through the available language choices: ENGLISH, DEUTSCH, FRANCAIS, ESPANOL, and ITALIANO.
- When finished, press to save the selection and move to Screen 2.

7.7.2 Program Mode Screen 2 – Select the auto restart mode.

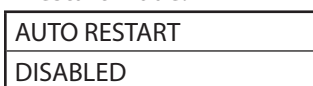

- Press to toggle between DISABLED and ENABLED.
- When finished, press to save the selection and move to Screen 3.

7.7.3 Program Mode Screen 3 – Select the service level.



- Press to toggle between NORMAL and SEVERE.
 - NORMAL service intervals are:
 - 4000 hours for filters
 - 8000 hours for desiccant
 - 4000 hours for valves
 - 4000 hours for catalyst
 - SEVERE service intervals are:
 - 2000 hours for filters
 - 4000 hours for desiccant
 - 2000 hours for valves
 - 2000 hours for catalyst
- **NOTE:** Time continues to accumulate as long as power is supplied to the controller, whether the controller is switched on or off.
- When finished Press to save the selection and move to Screen 4.

7.7.4 Program Mode Screen 4 – Reset the timer for filter service.

FILTER SERVICE
RESET? NO

- Press to toggle between NO and YES.
- When finished, press to acknowledge the selection and move to Screen 5.

7.7.5 Program Mode Screen 5 – Reset the timer for desiccant service.

DESICCANT SERVICE
RESET? NO

- Press to toggle between NO and YES.
- When finished, press to acknowledge the selection and move to Screen 6.

7.7.6 Program Mode Screen 6 – Reset the timer for valve service.

VALVE SERVICE
RESET? NO

- Press to toggle between NO and YES.
- When finished, press to acknowledge the selection and move to Screen 7.

7.7.7 Program Mode Screen 7 – Reset the timer for catalyst service.

CATALYST SERVICE
RESET? NO

- Press to toggle between NO and YES.
- When finished, press to acknowledge the selection and move to Screen 8.

7.7.8 Program Mode Screen 8 – Reset the valve cycle counter.

CYCLE COUNTER
RESET? NO

- Press to toggle between NO and YES.
- When finished, press to acknowledge the selection and exit Program Mode.

7.8 Setup Mode

- Press and hold for 3 seconds to enter Setup Mode.
- Setup Mode is comprised of the screens that are described below.
- There are three ways to exit Setup Mode.
 1. Press after making the selection in Screen 2 (if the dryer does not have electric drains) or Screen 3 (if the dryer has electric drains).
 2. At any screen, press and hold for 3 seconds.
 3. The controller automatically exits Setup Mode if no button is pressed within 60 seconds.

- One of two things will happen upon exiting Setup Mode.
 1. The controller will switch to Display Mode if DEMAND CYCLE or FIXED CYCLE was selected.
 2. The controller will switch to Test Mode if MANUAL CYCLE was selected.

7.8.1 Setup Mode Screen 1 – Display the dew point class.

ISO 8573 DEW PT
2: -40°C/-40°F

- Press to scroll through the choices:
 - 1: -73°C/-100°F
 - 2: -40°C/-40°F
- When finished, press to save the selection and move to Screen 2.

7.8.2 Setup Mode Screen 2 – Select the cycle type.

CYCLE TYPE
DEMAND CYCLE

- Press to scroll through the choices: DEMAND CYCLE or FIXED CYCLE.
- When finished, press to save the selection and move to Screen 3 (if the dryer has electric drains) or exit Setup Mode (if the dryer does not have electric drains).

7.8.3 Setup Mode Screen 3 – Test the drains.

TEST DRAIN ?
NO

- Press to toggle between NO and YES.
- Press to continue.
 - a. If NO was selected, the controller immediately exits Setup Mode.
 - b. If YES was selected, the controller energizes Drain 1 and Drain 2 for 4 seconds before exiting Setup Mode.

7.9 Alarm & Service Mode

Alarm & Service Mode is active when the controller is in Display Mode. It is not active in Program Mode, Setup Mode, or Test Mode.

NOTE: Alarm messages have priority over Service messages. Service messages have priority over Display messages. When an alarm occurs, Display Mode is disabled and only the alarm message is shown. When a service message is active, it takes the place of the corresponding service reminder in the Display Mode (e.g. "HOURS TO SERVICE FILTERS: XXXX" would be replaced by "SERVICE DRYER FILTERS").

7.9.1 Alarm messages

Alarm messages are displayed on a first-out basis with one exception. **The alarm caused by an open pressure switch at the end of the regeneration cycle, takes precedence over existing alarms.** See 7.9.1.1 (3).

7.9.1.1 Pressure Switch Alarms

There are three alarms for each tower that are triggered by the tower pressure switches. These alarms can occur in either the fixed or demand cycle. Following is a brief description of each alarm.

1. Left or right tower, drying, low pressure
 - Pressure switch open during drying cycle

2. Left or right tower, regenerating, high pressure
 - Pressure switch closed while purge valve is open (after an initial time delay)
3. Left or right tower, regenerating, low pressure
 - Pressure switch open at the end of the regenerating cycle

7.9.1.2 Thermistor Alarms

There are two alarms for each of the four thermistors. These alarms can only occur in the demand cycle. Following is a brief description of each alarm.

1. Left or right tower, upper or lower sensor, over-range
 - Temperature above 150°F (66°C)
 - Thermistor circuit shorted
2. Left or right tower, upper or lower sensor, under-range one cycle
 - Temperature below 40°F (4°C)
 - Thermistor circuit open

7.9.1.3 Inlet Air Alarms

1. Low inlet air pressure
 - Pressure switch opens when inlet air pressure falls below 60 psig (adjustable)
2. High inlet air temperature
 - Temperature switch opens when inlet air temperature rises above 140° F (adjustable)

7.9.1.4 Optional Device Alarms

1. Electric Drains with Alarm Contacts
 - Each drain has alarm contacts that connect to the Energy Savings Controller.
 - If the contacts open, then a drain alarm is indicated.

When an alarm condition occurs, the controller operates as follows.

- The alarm LED blinks and the appropriate alarm message is shown on the text display.
- The dryer continues to cycle normally (see below for exception). **NOTE:**The LEDs for the valves, pressure switches, and desiccant towers are not used for alarm indication (as in the Standard Controller).
- If the alarm condition clears for one cycle, then the alarm LED stops blinking (LED on); the alarm message continues to be displayed.
- **Exception: If the alarm is caused by the condition in Section 7.9.1, then the cycle stops.** Once the alarm condition is corrected, the alarm LED stops blinking (LED on) and the cycle continues normally; the alarm message continues to be displayed.
- In the demand cycle, the control switches to a fixed 10 minute cycle when the alarm LED begins blinking. Control switches back to the selected demand cycle after the alarm condition clears. This applies to pressure switch and thermistor alarms, but not to drain alarms.
- When the alarm condition is corrected, press the reset button to extinguish the alarm LED and to clear the alarm message from the text display.

The following text display is shown for each alarm. The second line of the alarm screens contains up to three messages, which are scrolled through, displaying each one for 3 seconds after the alarm condition clears.

7.9.1.5 Alarm Mode Screen 1 – Left Tower Drying – Low Pressure (Open Pressure Switch Circuit)

ALARM
LEFT TOWER DRYING LOW PRESSURE

7.9.1.6 Alarm Mode Screen 2 – Left Tower Regenerating – High Pressure (Closed Pressure Switch Circuit)

ALARM
LEFT TOWER REGENERATING HIGH PRESSURE

7.9.1.7 Alarm Mode Screen 3 – Left Tower Regenerating – Low Pressure (Open Pressure Switch Circuit)

ALARM
LEFT TOWER REGENERATING LOW PRESSURE

7.9.1.8 Alarm Mode Screen 4 – Left Tower, Upper Sensor (Thermistor) Under-Range

ALARM
LEFT TOWER UPPER SENSOR UNDER-RANGE

7.9.1.9 Alarm Mode Screen 5 – Left Tower, Upper Sensor (Thermistor) Over-Range

ALARM
LEFT TOWER UPPER SENSOR OVER-RANGE

7.9.1.10 Alarm Mode Screen 6 – Left Tower, Lower Sensor (Thermistor) Under-Range

ALARM
LEFT TOWER LOWER SENSOR UNDER-RANGE

7.9.1.11 Alarm Mode Screen 7 – Left Tower, Lower Sensor (Thermistor) Over-Range

ALARM
LEFT TOWER LOWER SENSOR OVER-RANGE

7.9.1.12 Alarm Mode Screen 8 – Right Tower Drying – Low Pressure (Open Pressure Switch Circuit)

ALARM
RIGHT TOWER DRYING LOW PRESSURE

7.9.1.13 Alarm Mode Screen 9 – Right Tower Regenerating – High Pressure (Closed Pressure Switch Circuit)

ALARM
RIGHT TOWER REGENERATING HIGH PRESSURE

7.9.1.14 Alarm Mode Screen 10 – Right Tower Regenerating – Low Pressure (Open Pressure Switch Circuit)

ALARM
RIGHT TOWER REGENERATING LOW PRESSURE

7.9.1.15 Alarm Mode Screen 11 – Right Tower, Upper Sensor (Thermistor) Under-Range

ALARM
RIGHT TOWER UPPER SENSOR UNDER-RANGE

7.9.1.16 Alarm Mode Screen 12 – Right Tower, Upper Sensor (Thermistor) Over-Range

ALARM
RIGHT TOWER UPPER SENSOR OVER-RANGE

7.9.1.17 Alarm Mode Screen 13 – Right Tower, Lower Sensor (Thermistor) Under-Range

ALARM
RIGHT TOWER LOWER SENSOR UNDER-RANGE

7.9.1.18 Alarm Mode Screen 14 – Right Tower, Lower Sensor (Thermistor) Over-Range

ALARM
RIGHT TOWER LOWER SENSOR OVER-RANGE

7.9.1.19 Alarm Mode Screen 15 – Alarm Drain 1

ALARM
DRAIN 1

7.9.1.20 Alarm Mode Screen 16 – Alarm Drain 2

ALARM
DRAIN 2

7.9.1.21 Alarm Mode Screen 17 – Low Inlet Air Pressure

ALARM
INLET AIR LOW PRESSURE

7.9.1.22 Alarm Mode Screen 18 – High Inlet Air Temperature

ALARM
INLET AIR HIGH TEMPERATURE

7.9.2 Service messages

There are two service levels (normal and severe) as described in Program Mode. Each service level has preset time intervals for servicing the filters, desiccant, valves, and catalyst. Time continues to accumulate as long as power is supplied to the controller, whether the controller is switched on or off.

When a service time interval expires, the controller operates as follows.

- The service LED blinks and the appropriate service message is shown on the text display. (See 7.9.1)
- When the service interval for filters has expired the three filter LEDs also blink.
- The dryer continues to cycle normally.
NOTE: The LEDs for the valves, pressure switches, and desiccant towers are not used for service indication (as in the Standard Controller).

To extinguish the service LED and clear the service message from the text display, go to Program Mode and reset the appropriate service timer.

The following text display is shown for each service message. Replacement or repair of the affected item may or may not be necessary. The service reminders are used to schedule routine evaluation of the operational status of key components.

7.9.2.1 Service Mode Screen 1 – Service filters

SERVICE DRYER
FILTERS

Check filter Delta-P gauges and ensure that drains are functioning properly. Inspect pilot air filter element.

7.9.2.2 Service Mode Screen 2 – Service desiccant

SERVICE DRYER
DESICCANT

Check moisture indicator or outlet dew point and inspect mufflers for excessive dusting.

7.9.2.3 Service Mode Screen 3 – Service valves

SERVICE DRYER
VALVES

Ensure that valves are cycling properly. Check for switching failure alarms and adjust purge pressure. Check for leaks.

7.9.2.4 Service Mode Screen 4 – Service catalyst

SERVICE DRYER
CATALYST

Check moisture indicator and carbon monoxide concentration at outlet.

7.10 Display Mode

- Display Mode is active when the user exits Program Mode or Setup Mode (unless MANUAL cycle was selected in Setup Mode) and no alarms are active.
- The LEDs for the valves, pressure switches, and desiccant towers operate in the same manner as in the Standard Controller, except in the case of an alarm or service reminder (see 5.b and 7.b in Alarm & Service Mode).
- Display Mode is comprised of several screens (described below). The controller automatically scrolls through the screens, displaying each one for 4 seconds. The user can override the 4 second time period and force the next screen to be displayed by pressing .
- The screens are displayed in the following sequence: 1, 2, 3A, 4, 5, 6, 1, 2, 3B, 4, 5, 6, 1, 2, 3C, 4, 5, 6, 1, 2, 3D, 4, 5, 6, ... with the exceptions noted below.

7.10.1 Display Mode Screen 1 – Dew point class and cycle type.

2: -40°C/-40°F
DEMAND CYCLE

7.10.2 Display Mode Screen 2 – Energy savings.

This screen is not displayed if FIXED cycle is selected.

ENERGY SAVINGS
XX%

7.10.3 Display Mode Screen 3A – Service reminder (filters).

HOURS TO SERVICE
FILTERS: XXXX

7.10.4 Display Mode Screen 3B – Service reminder (desiccant).

HOURS TO SERVICE
DESICCANT: XXXX

7.10.5 Display Mode Screen 3C – Service reminder (valves).

HOURS TO SERVICE
VALVES: XXXX

7.10.6 Display Mode Screen 3D – Service reminder (catalyst).





HOURS TO SERVICE
CATALYST: XXXX

7.10.7 Display Mode Screen 3E – Valve cycle counter.

CYCLE COUNTER
XXXXXXXX

7.11 Test Mode

- Test Mode is active when the user exits Setup Mode after selecting operation in MANUAL CYCLE.
- Test Mode is comprised of eight screens (descriptions follow Table 7.2). Each screen corresponds to one of eight program steps (described in Table 7.2).

- Press  to advance from one screen (program step) to the next. Be sure to read and understand all cautions listed with the screen (program step) descriptions.
- If the temperature is below 40°F or the thermistor circuit is open, the second line of the display will read "UNDER-RANGE" instead of the temperature reading. (Refer to screens 2, 3, 4, 6, 7, and 8.)
- If the temperature is above 150°F or the thermistor circuit is shorted, the second line of the display will read "OVER-RANGE" instead of the temperature reading. (Refer to screens 2, 3, 4, 6, 7, and 8.)
- Upon entering Test Mode, the program can be at any one of the eight steps.
- To exit Test Mode:
 1. Use  to manually advance the program to step 1 or 5.
 - a) The program must be set at step 1 or 5 to exit Test Mode.
 - b) Screen 9 is displayed for 3 seconds if the user attempts to exit the program from step 2, 3, or 4.
 - c) Screen 10 is displayed for 3 seconds if the user attempts to exit the program from step 6, 7, or 8.
 2. Press and hold  for 3 seconds to exit Test Mode. The display switches to Screen 2 of Setup Mode.
 3. Use  to select DEMAND CYCLE or FIXED CYCLE.
 4. Press  to accept the selection and activate Display Mode.

7.11.1 Test Mode Screen 1 – Step 1

TEST MODE STEP 1
OK TO EXIT NOW

- No temperature display on this screen.
- Press  to advance to screen 2.

7.11.2 Test Mode Screen 2 – Step 2

TEST MODE STEP 2
XX°C XXX°F

- The left tower drying light is blinking to indicate the thermistor location (upper left) that corresponds to the temperature display.
- Press  to advance to screen 3.

7.11.3 Test Mode Screen 3 – Step 3

TEST MODE STEP 3
XX°C XXX°F

- The right tower regenerating light is blinking to indicate the thermistor location (lower right) that corresponds to the temperature display.
- Press  to advance to screen 4.

7.11.4 Test Mode Screen 4 – Step 4

TEST MODE STEP 4
XX°C XXX°F

- The left tower drying light is blinking to indicate the thermistor location (upper left) that corresponds to the temperature display.
- **CAUTION: Do not advance to step 5 until the right tower has fully pressurized.**
- Press  to advance to screen 5.

7.11.5 Test Mode Screen 5 – Step 5

TEST MODE STEP 5
OK TO EXIT NOW

- No temperature display on this screen.
- Press  to advance to screen 6.

7.11.6 Test Mode Screen 6 – Step 6

TEST MODE STEP 6
XX°C XXX°F

- The right tower drying light is blinking to indicate the thermistor location (upper right) that corresponds to the temperature display.
- Press  to advance to screen 7.

7.11.7 Test Mode Screen 7 – Step 7

TEST MODE STEP 7
XX°C XXX°F

- The left tower regenerating light is blinking to indicate the thermistor location (lower left) that corresponds to the temperature display.
- Press  to advance to screen 8.

7.11.8 Test Mode Screen 8 – Step 8

TEST MODE STEP 8
XX°C XXX°F

- The right tower drying light is blinking to indicate the thermistor location (upper right) that corresponds to the temperature display.
- **CAUTION: Do not advance to step 1 until the left tower has fully pressurized.**
- Press  to advance to screen 1.

7.11.9 Test Mode Screen 9 – Attempting to exit test mode from step 2, 3, or 4

TO EXIT TEST
GO TO STEP 5

- This screen is displayed for 5 seconds if the user attempts to exit test mode from step 2, 3, or 4.
- At the end of the 5-second time period, the display returns to the previous screen (2, 3, or 4).

7.11.10 Test Mode Screen 10 – Attempting to exit test mode from step 6, 7, or 8.

TO EXIT TEST
GO TO STEP 1

- This screen is displayed for 5 seconds if the user attempts to exit test mode from step 6, 7, or 8.
- At the end of the 5-second time period, the display returns to the previous screen (6, 7, or 8).

Program Step	1	2	3	4	5	6	7	8
Left tower status	drying	drying	drying	drying	regen.	regen.	regen.	regen.
Right tower status	regen.	regen.	regen.	regen.	drying	drying	drying	drying
Left tower pressure switch	closed	closed	closed	closed	closed	closed	closed at start, open at end	open at start, closed at end
Right tower pressure switch	closed	closed	closed at start, open at end	open at start, closed at end	closed	closed	closed	closed
Left purge solenoid	off	off	off	off	off	off	on	off
Right purge solenoid	off	off	on	off	off	off	off	off
	open to left chamber				open to right chamber			
Left purge valve	closed	closed	closed	closed	closed	closed	open	closed
Right purge valve	closed	closed	open	closed	closed	closed	closed	closed
Temperature display - thermistor location	none	upper left	lower right	upper left	none	upper right	lower left	upper right

**Table 7-2
Cycle Sequence Steps**

Dryer MOP	60-150 psig	
ISO Class	1	2
Dew Point	-73°C	-40°C
	-100°F	-40°F
Cycle Time (minutes)	4	10
Time	Time from start of cycle (minutes : seconds)	
t0	00:00	00:00
t1	00:02	00:02
t2	00:06	00:06
t3	01:12	04:00
t4	02:00	05:00
t5	02:02	05:02
t6	02:06	05:06
t7	03:12	09:00
t8	04:00	10:00
Reference Data		
Purge time (min:sec)	01:06	03:54
Purge time (min:sec)	00:48	01:00

**Table 7-3
Fixed Cycle Timing – Energy Savings Controller**

NOTE: When operated in the Demand Mode, drying times t4-t0 and t8-t4 can extend to a maximum of 30 minutes each. Purge times in the Demand Mode, regardless of the ISO Class selection, will always be equal to the purge times of the ISO Class 2 (10 min.) Fixed Cycle (3:54 for 150 psig MOP and 2:54 for 250 psig MOP).

Process valve name (Process valve state w/ de-energized pilot solenoid valve)	Time (refer to Table 7-3)								
	t0	t1	t2	t3	t4	t5	t6	t7	t8
	Left Tower Drying Right Tower Regenerating Half Cycle				Right Tower Drying Left Tower Regenerating Half Cycle				
Left purge valve (normally closed)								Pilot Energized (open)	
Right purge valve (normally closed)			Pilot Energized (open)						
Normal status of pressure switches									
Left tower pressure switch	closed	closed	closed	closed	closed	closed	closed	closed for < 5 sec. then open	open at t7, closed before t8
Right tower pressure switch	closed	closed	closed for < 5 sec. then open	open at t3, closed before t4	closed	closed	closed	closed	closed
Pressure switch status that causes an alarm									
Left tower drying Low tower pressure ^a			open ¹	open ¹					
Left tower regenerating Fail to de-pressurize ^b							closed ¹		
Left tower regenerating Fail to re-pressurize ^c									open ²
Right tower drying Low tower pressure ^d							open ¹		open ¹
Right tower regenerating Fail to de-pressurize ^e			closed ¹						
Right tower regenerating Fail to re-pressurize ^f				open ²					
NOTE	Stop cycle on fault	Comments							
1: Check for fault condition at 15, 25, 35,... seconds into the half-cycle	no	If the fault condition is clear for 1 cycle: the alarm LED stays on (without blinking) and the alarm message continues to be displayed. Once the fault condition is clear, pressing the reset button will clear the alarm LED and message.							
2: Check for fault condition just before the end of the half- cycle	yes	If the fault condition clears: tower cycling resumes and the alarm LED stays on (without blinking). Once the fault condition is clear, pressing the reset button will clear the alarm LED and message.							
a: Blink the Alarm LED and display the following text message: Alarm + Left Tower Drying + Low Pressure									
b: Blink the Alarm LED and display the following text message: Alarm + Left Tower Regenerating + High Pressure									
c: Blink the Alarm LED and display the following text message: Alarm + Left Tower Regenerating + Low Pressure									
d: Blink the Alarm LED and display the following text message: Alarm + Right Tower Drying + Low Pressure									
e: Blink the Alarm LED and display the following text message: Alarm + Right Tower Regenerating + High Pressure									
f: Blink the Alarm LED and display the following text message: Alarm + Right Tower Regenerating + Low Pressure									

Table 7-4
Event Sequence and Component Status – Energy Savings Controller

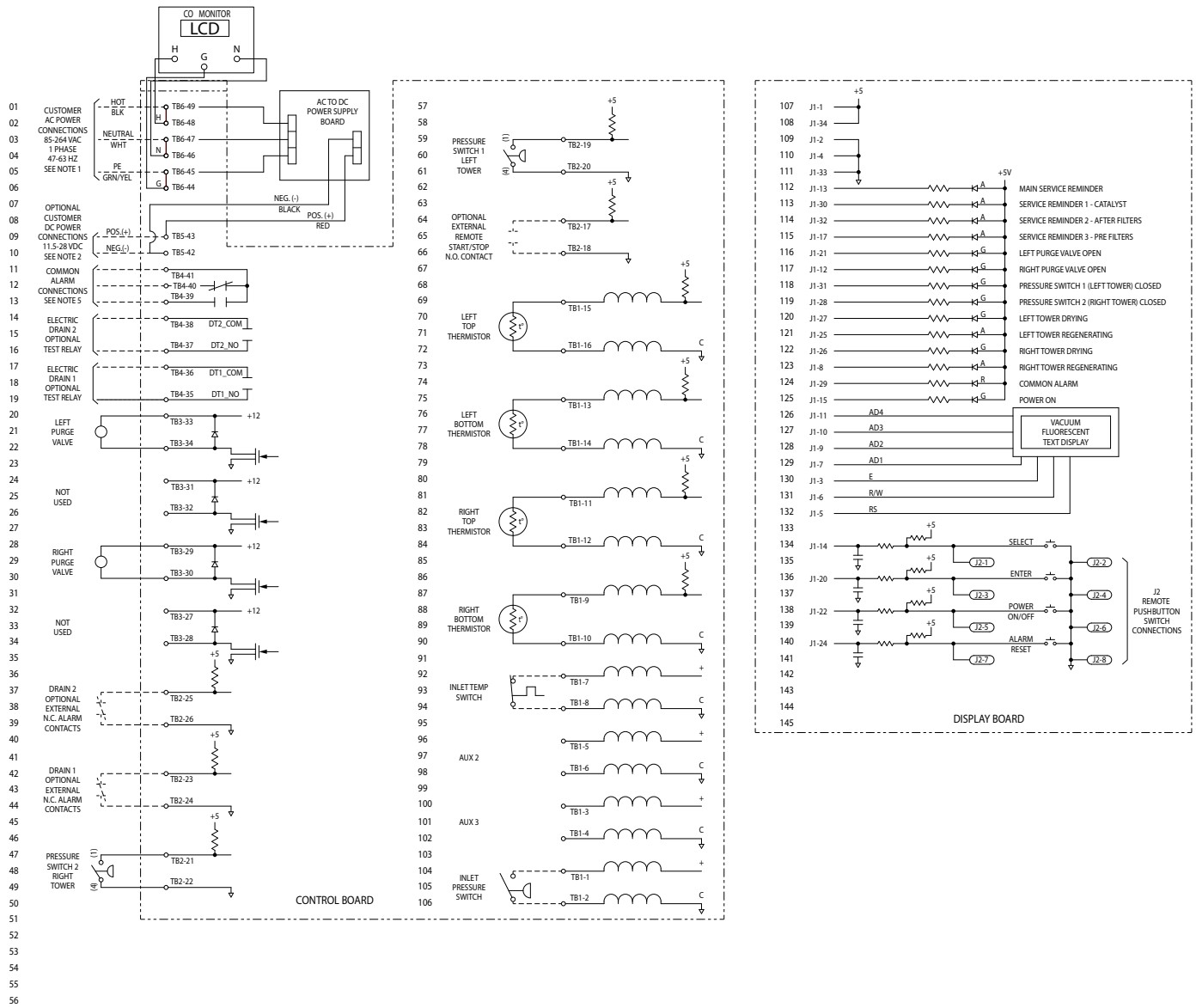

NOTES:

1. CUSTOMER POWER CONNECTIONS WHEN SUPPLY VOLTAGE IS AC (ALTERNATING CURRENT). TERMINALS TB6-44, TB6-46, AND TB6-48 CAN BE USED TO PROVIDE ACCESSORY POWER AT THE SAME VOLTAGE AND FREQUENCY. AC POWER IS DIRECTED TO THE POWER SUPPLY BOARD WHERE IT IS CONVERTED TO 12 VDC AND RETURNED TO THE CONTROL BOARD.
2. CUSTOMER POWER CONNECTIONS WHEN SUPPLY VOLTAGE IS DC (DIRECT CURRENT). RED AND BLACK WIRES FROM THE POWER SUPPLY BOARD SHOULD BE REMOVED AND THE CUSTOMER SHOULD MAKE THEIR POWER CONNECTIONS AT TERMINALS TB5-42 AND TB5-43.
3. VOLTAGE RATING OF VALVES IS 12 VDC.
4. VOLTAGE RATING OF SWITCHES IS 5 VDC.
5. WITH UNIT ON AND NO ALARMS, THERE SHOULD BE CONTINUITY BETWEEN TERMINALS TB4-39 AND TB4-41. DRY CONTACTS RATED AT 250VAC/5A (MAX.) OR 24VDC/2A (MAX.).

Figure 7-2
Electrical Schematic – Energy Savings Controller

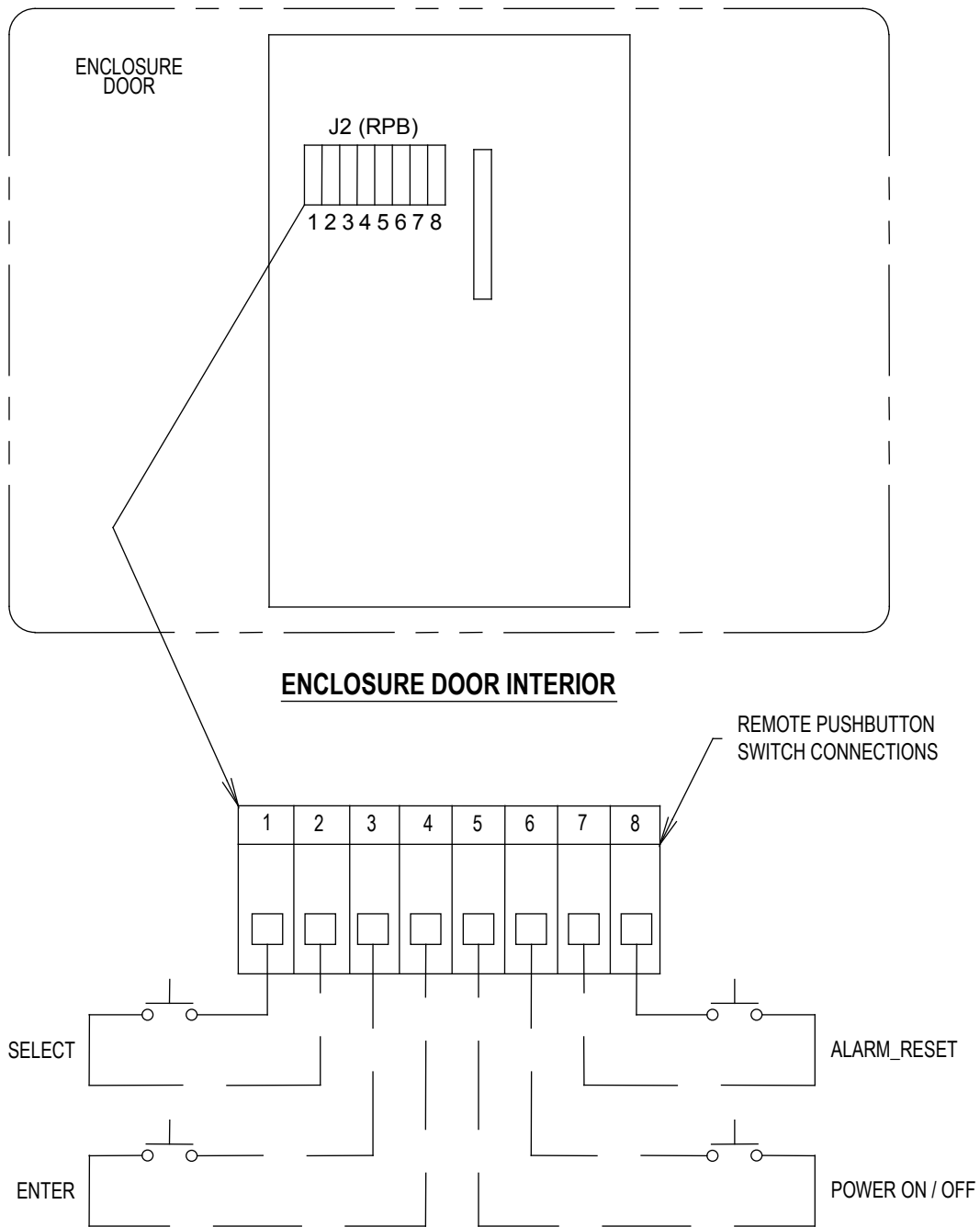
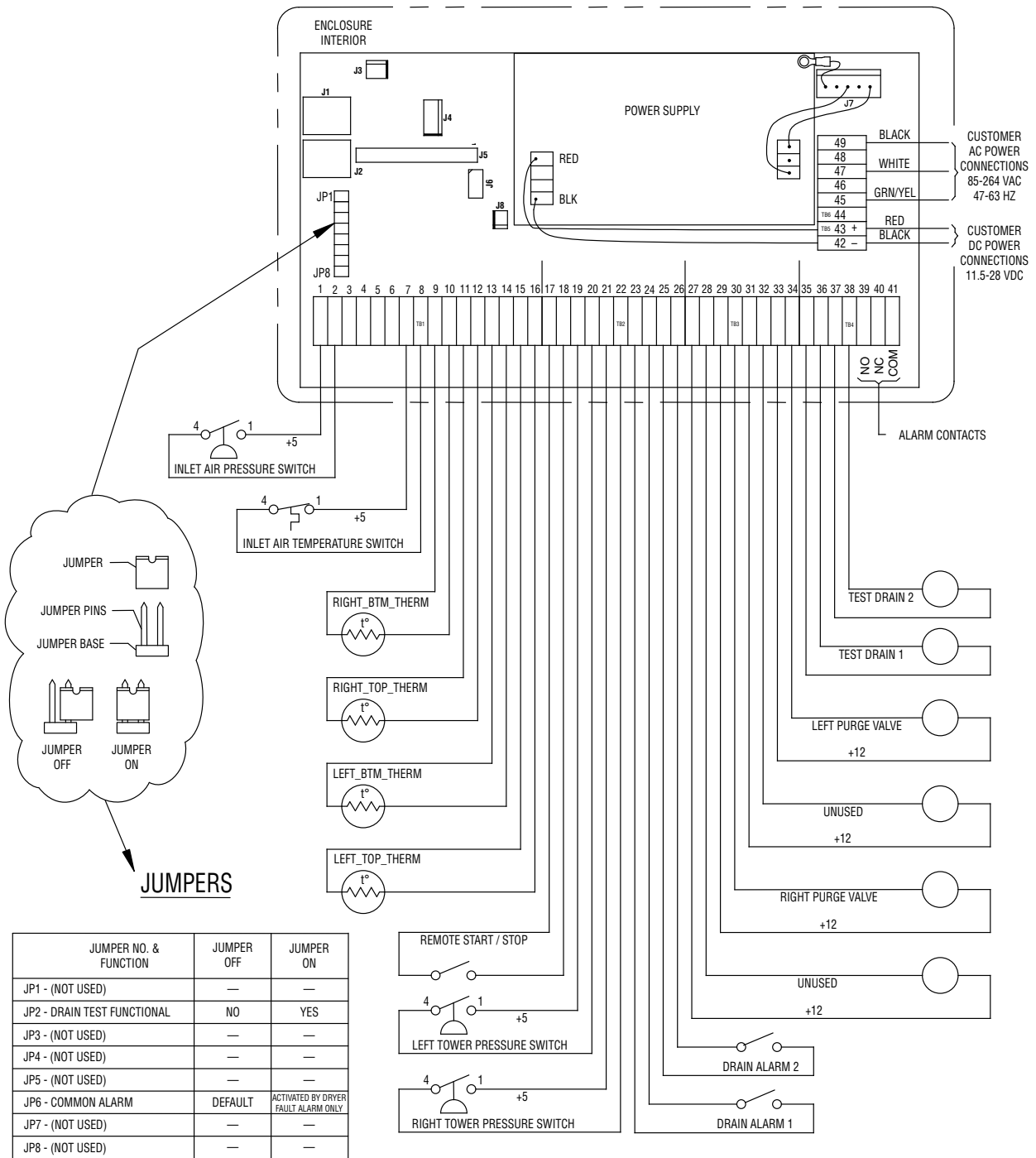

Figure 7-3
 Point-to-Point Diagram – Energy Savings Controller
 (continued on next page)



NOTES:

- SEE FIGURE 7-5 FOR RECOMMENDED AWG CONDUCTOR SIZES.
- CUSTOMER SUPPLIED AC (ALTERNATING CURRENT) INPUT POWER CONNECTIONS SHOULD BE MADE AT TERMINALS TB6-44, TB6-46 AND TB6-48. FOR CUSTOMER SUPPLIED DC (DIRECT CURRENT) POWER, THE RED AND BLACK WIRES FROM THE POWER SUPPLY BOARD SHOULD BE REMOVED AND THE CUSTOMER POWER CONNECTIONS SHOULD BE MADE AT TERMINALS TB5-42 AND TB5-43.
- IN THE 'JUMPER OFF' POSITION, THE JUMPER CAN BE COMPLETELY REMOVED OR STORED ON A SINGLE PIN. IN THE 'JUMPER ON' POSITION, THE JUMPER IS INSTALLED ACROSS BOTH PINS TO PROVIDE CONTINUITY.
- WITH UNIT ON AND NO ALARMS, THERE SHOULD BE CONTINUITY BETWEEN TERMINALS TB4-39 AND TB4-41. CONTACTS ARE RATED AT 5 AMPS.

Figure 7-3
Point-to-Point Diagram – Energy Savings Controller
 (continued from previous page)

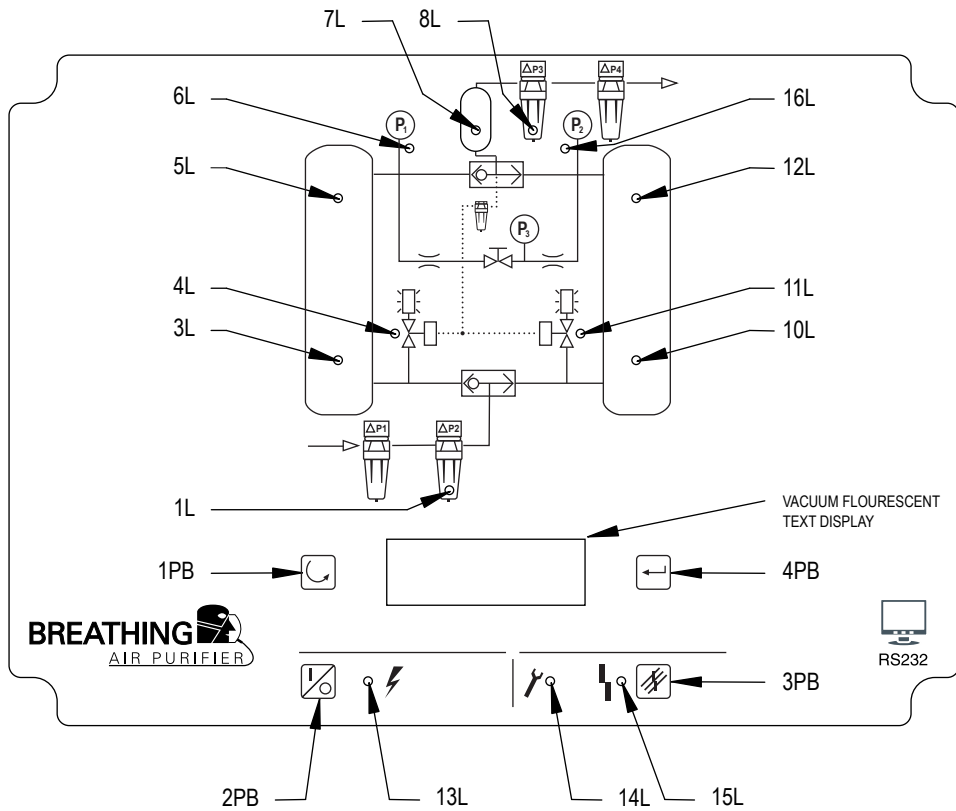

LEGEND

ENCLOSURE DOOR EXTERIOR

- | | | |
|---|--|---------------------------------|
| 1L SERVICE REMINDER 3 - PRE FILTERS (AMBER) | 15L COMMON ALARM (RED) | J3 RS232 SERIAL I/O CONNECTOR |
| 3L LEFT TOWER REGENERATING (AMBER) | 16L PRESSURE SWITCH 2 (RIGHT TOWER) CLOSED (GREEN) | J4 PICPROG. CONNECTOR |
| 4L LEFT PURGE VALVE OPEN (GREEN) | 1PB SELECT SWITCH | J6 XILINX PROGRAM CONNECTOR |
| 5L LEFT TOWER DRYING (GREEN) | 2PB POWER ON/OFF SWITCH | J7 POWER SUPPLY INPUT CONNECTOR |
| 6L PRESSURE SWITCH 1 (LEFT TOWER) CLOSED (GREEN) | 3PB ALARM RESET SWITCH | PS AC TO DC POWER SUPPLY |
| 7L SERVICE REMINDER 1 - CATALYTIC CONVERTER CARTRIDGE (AMBER) | 4PB ENTER SWITCH | RPB REMOTE SWITCH TERMINALS |
| 8L SERVICE REMINDER 2 - AFTER FILTERS (AMBER) | CNTRLPCB CONTROL BOARD | TB1 ANALOG INPUT TERMINALS |
| 10L RIGHT TOWER REGENERATING (AMBER) | CR ALARM CONTROL RELAY | TB2 SWITCH INPUT TERMINALS |
| 11L RIGHT PURGE VALVE OPEN (GREEN) | DISPPCB DISPLAY BOARD | TB3 VALVE OUTPUT TERMINALS |
| 12L RIGHT TOWER DRYING (GREEN) | JMP CONFIGURATION JUMPERS | TB4 CONTACT OUTPUT TERMINALS |
| 13L POWER ON INDICATOR (GREEN) | J1 FILTER MONITOR 2 CONNECTOR | TB5 DC POWER INPUT TERMINALS |
| 14L MAIN SERVICE REMINDER (AMBER) | J2 FILTER MONITOR 1 CONNECTOR | TB6 AC POWER INPUT TERMINALS |

**Figure 7-4
Panel Layout – Energy Savings Controller
(continued on next page)**

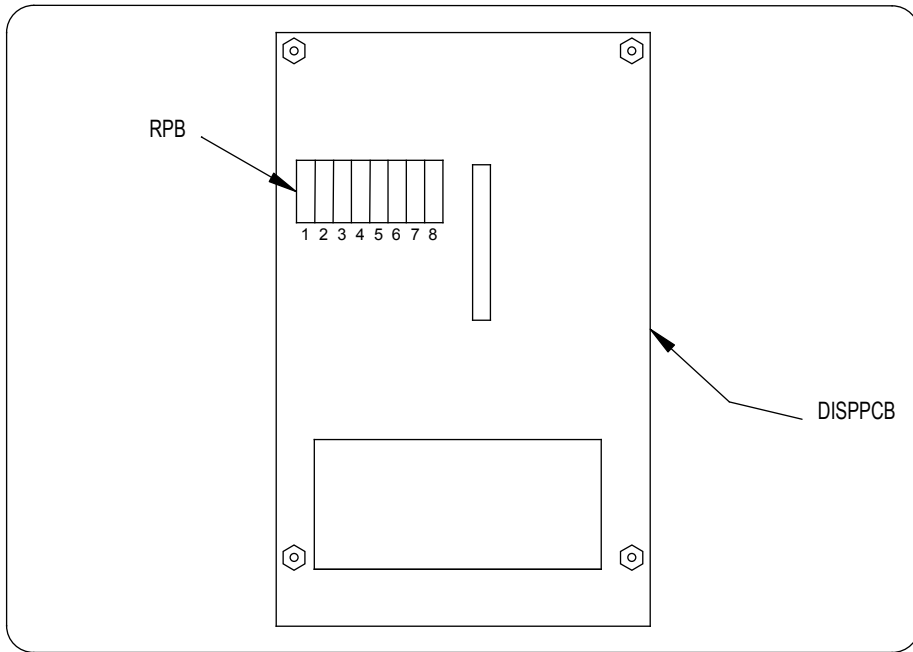

ENCLOSURE DOOR INTERIOR

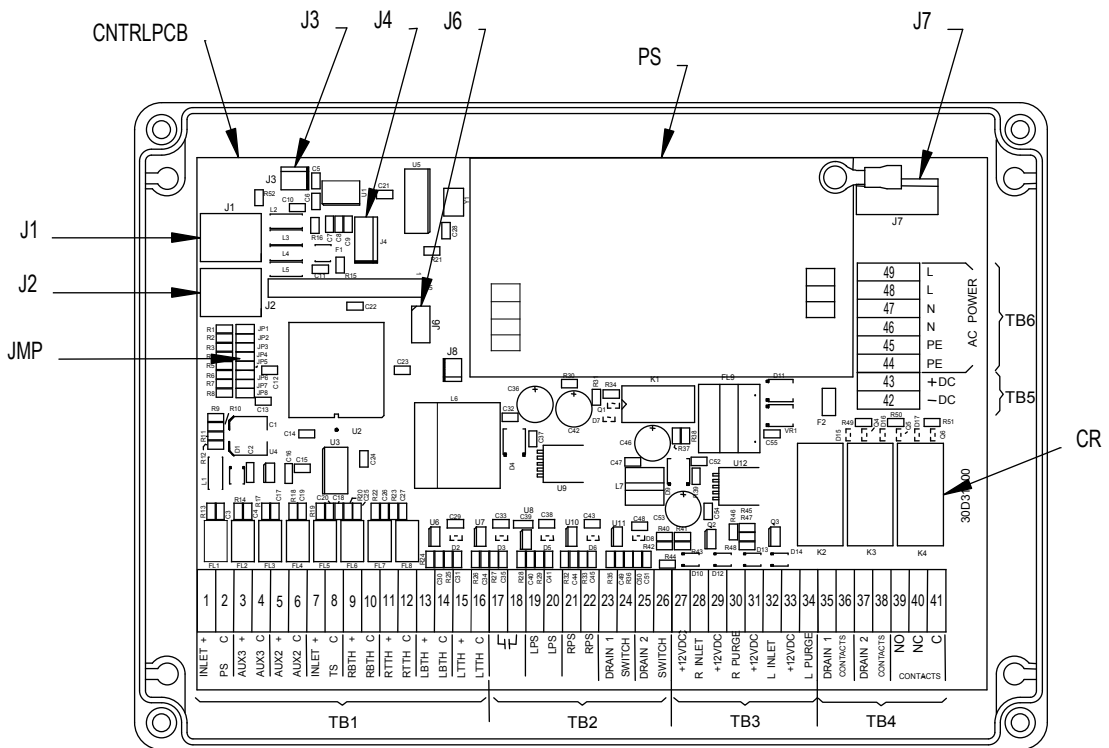

ENCLOSURE INTERIOR

Figure 7-4
Panel Layout – Energy Savings Controller
(continued from previous page)

LOCATION	FUNCTION		# OF CONDUCTORS	AWG SIZE	CABLE DIAMETER RANGE				CONNECTOR SIZE	ENCLOSURE HOLE DIA.		
					MIN. DIA.		MAX. DIA.			in.	mm	
					in.	mm	in.	mm				
1	FACTORY CONNECTIONS OPTIONAL DEVICES	HUMIDITY-DEW POINT SENSOR	2	22	0.230	5.8	0.395	10.0	PG-11	0.733	18.6	
		DRAIN 1 (POWER & TEST)	4									
		DRAIN 1 (ALARM)	2									
		DRAIN 2 (POWER & TEST)	4									
		DRAIN 2 (ALARM)	2									
2	FACTORY CONNECTIONS OPTIONAL DEVICES	ANALOG INPUT 1	2	22	0.230	5.8	0.395	10.0	PG-11	0.733	18.6	
		ANALOG INPUT 2	2									
		ANALOG INPUT 3	2									
3	FACTORY CONNECTIONS STANDARD DEVICES	THERMISTOR 1 LEFT TOWER - UPPER	2	22	0.114	2.9	0.250	6.4	PG-7	0.492	12.5	
4		THERMISTOR 2 RIGHT TOWER - UPPER	2	22	0.114	2.9	0.250	6.4	PG-7	0.492	12.5	
5		THERMISTOR 3 LEFT TOWER - LOWER	2	22	0.114	2.9	0.250	6.4	PG-7	0.492	12.5	
6		THERMISTOR 4 RIGHT TOWER - LOWER	2	22	0.114	2.9	0.250	6.4	PG-7	0.492	12.5	
7		PRESSURE SWITCH - RIGHT TOWER	2	18	0.181	4.6	0.312	7.9	PG-9	0.599	15.2	
8		PRESSURE SWITCH - LEFT TOWER	2	18	0.181	4.6	0.312	7.9	PG-9	0.599	15.2	
9		SOLENOID - LEFT PURGE VALVE	2	18	0.181	4.6	0.312	7.9	PG-9	0.599	15.2	
10		PRESSURE SWITCH - INLET AIR	2	18	0.181	4.6	0.312	7.9	PG-9	0.599	15.2	
11		SOLENOID - RIGHT PURGE VALVE	2	18	0.181	4.6	0.312	7.9	PG-9	0.599	15.2	
12		TEMPERATURE SWITCH - INLET AIR	2	18	0.181	4.6	0.312	7.9	PG-9	0.599	15.2	
13		USER CONNECTIONS	ALARM CONTACTS	2	16	0.181	4.6	0.312	7.9	PG-9	0.599	15.2
14			REMOTE STOP / START	2	16	0.181	4.6	0.312	7.9	PG-9	0.599	15.2
15	RS232		3	22	0.114	2.9	0.250	6.4	PG-7	0.492	12.5	
16	INPUT POWER		3	14	0.230	5.8	0.395	10.0	PG-11	0.733	18.6	

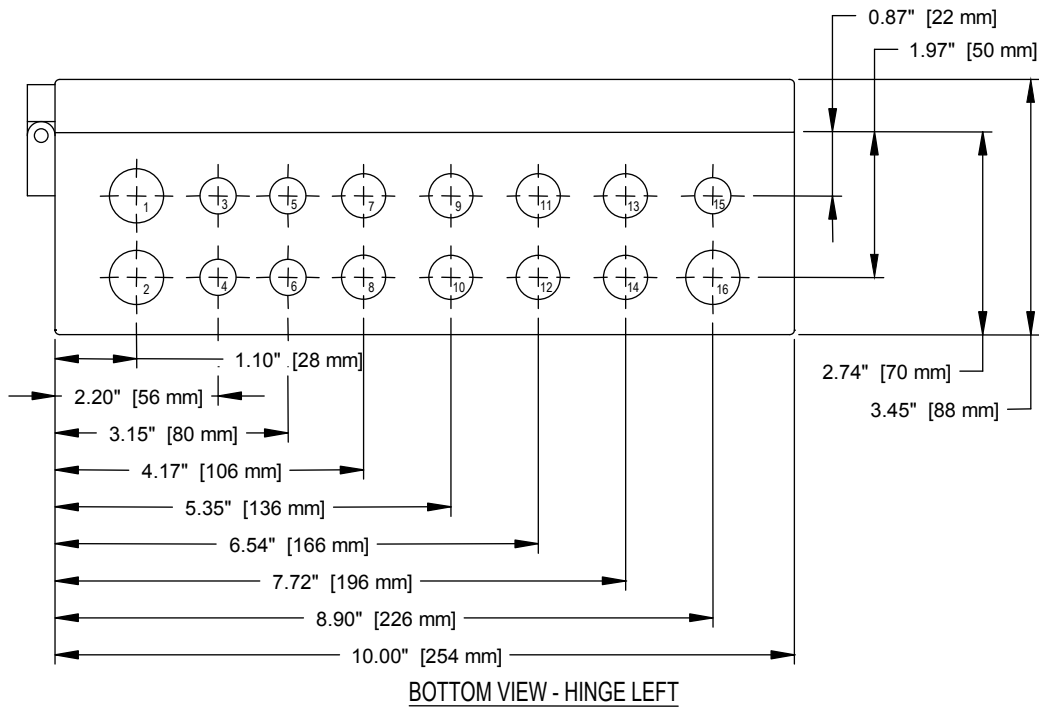

Figure 7-5
Enclosure Penetrations – Energy Savings Controller

8.0 Operation

8.1 Start-up

8.1.1 Controller Settings (Standard Controller or Energy Savings Controller)

- Set or verify settings on the Standard Controller or Energy Savings Controller. General information regarding both controllers can be found in section 5. Detailed operational points are presented in sections 6 and 7.

WARNING: Enclosure may have live electric parts. De-energize dryer before opening enclosure.

- If a Cycle or Energy (purge) Savings % change is made while the dryer is operating, the change will occur at the end of the current half-cycle. If it is necessary to begin a new selection immediately, shut the unit off and then back on.

NOTE: A tower that is actively purging when the power on/off button is actuated will be subjected to a rapid repressurization that can lead to fluidization and subsequent abrasion of the desiccant bed. Ideally, dryers should only be powered off during those portions of the drying cycle when both desiccant towers are at full operating pressure.

- If switching to a cycle mode producing a lower dew point (e.g. -40°F to -100°F [-40°C to -73°C]) while the dryer is operating, one or two days of operation may be needed before the new dew point is achieved.

8.1.2 Initial Pressurization

- SLOWLY pressurize dryer to full line pressure. (If the dryer was installed with inlet and outlet isolation valves, the inlet isolation valve should be slowly opened while the outlet isolation valve remains closed.)
- During initial start-up, check the entire system for leaks. If necessary, de-pressurize the dryer and correct any leaks.

8.1.3 Energizing the Purifier

- Energize the Purifier using the power switch located on the control panel.
- **NOTE:** The switching failure alarm may be activated if the unit is energized before it is pressurized. To deactivate alarm, allow dryer to cycle to next step and press the reset button.

8.1.4 Adjusting the Purge Rate

Determine the following:

- Maximum operating pressure (MOP) of dryer from the dryer serial number tag.
- Air pressure at inlet to dryer.

8.1.4.1 Purge Rate Pressure –

- Refer to Table 8-4 for the proper purge rate pressure setting corresponding to the conditions listed in Section 8.1.4.
- Adjust purge rate valve until purge pressure gauge indicates the required pressure. The purge pressure adjustment valve is a quarter-turn ball valve located in the smaller bypass line of the upper piping in the rear of the dryer. Refer to Figure 4-2. Equally sized orifices are located at either end of the bypass line. The purge pressure adjustment valve, and a pressure tap for the purge pressure gauge are piped between the two orifices. Looking at the front of the dryer, when the left tower is drying and the right tower is purging, purge air flows from left to right through the first orifice, then the purge pressure adjustment valve, past the pressure tap for the purge pressure gauge, through the second and final orifice and into the offline tower. The pressure in the purge circuit just before the final

orifice controls the purge flow rate. Because the purge pressure tap lies between the purge pressure adjustment valve and the orifice closest to the right hand tower, the purge pressure can only be correctly read and adjusted when the purge flow is from left to right. This only occurs when the right hand tower is actively purging. **IMPORTANT:** Purge pressure adjustment must be made while the RIGHT HAND TOWER AS SEEN FROM THE FRONT OF THE UNIT is regenerating and the right hand tower is actively purging (the purge valve associated with the right tower is open and air is exhausting from its muffler). Due to the symmetry of the design, identical orifices at opposite ends and the bi-directional flow characteristics of the purge pressure adjustment ball valve, purge flow will be similar when towers switch and the purge flow is from the drying tower on the right towards the regenerating tower on the left. Purge pressure as indicated by the purge pressure gauge should be disregarded during this half of the operating cycle.

- The purge pressure adjustment valve should never be fully closed. Proper purge flow is required to regenerate and re-pressurize the offline tower. Should the tower fail to re-pressurize, a switching failure alarm will be initiated, and the cycle will be stopped before tower switch over.
- After the purge pressure has been correctly set, the handle of the purge pressure adjustment valve may be removed and stored to prevent tampering with the setting.

Insufficient purge air will eventually result in saturation of the desiccant beds and wet air downstream. Verify that maximum operating pressure mode, cycle time, energy (purge) savings percent selection, and purge pressure are correctly set.

8.1.5 Bringing the Purifier Online

Establish a normal flow through the Purifier. Slowly open the outlet isolation valve if present. Close any dryer by-pass valves.

8.1.6 Readjusting the Purge Rate

With the inlet pressure to the dryer at its minimum level, readjust the purge pressure per the instructions in Section 8.1.4.

NOTE: Adjustment must be made while the appropriate tower is purging (air exhausting from muffler).

8.2 Operational Check Points

8.2.1 Power to unit

Check periodically that there is power to the unit (indicating lights illuminated).

8.2.2 Moisture Indicator

Every four hours check moisture indicator. Indicator should be green. The color change moisture indicator indicates the outlet relative humidity of the desiccant dryer.

Green indicates a R.H. below 3% and yellow indicates a R.H. above 3%. Table 8-5 cross references outlet pressure dew points to moisture indicator changes from green to yellow at various inlet temperatures.

NOTE: During start-up the indicator may be yellow, however, it should begin to change to green within four hours.

8.2.3 Purge Pressure Setting

Every four hours check the purge pressure gauge for the proper setting and adjust as required. Adjustment should be made when the inlet pressure to the dryer is at its minimum level.

NOTE: Adjustment must be made while the appropriate tower is purging (air exhausting from muffler).

8.2.4 Alarms

Periodically check for flashing red alarm LED.

8.2.4.1 Alarms – Standard Controller

Alarm light will flash if either tower fails to pressurize or de-pressurize to the required levels at the proper time. Refer to Section 6.4.3 and Table 6.6.

NOTE: Alarm will activate if dryer is energized without being pressurized. If this occurs, allow dryer to cycle to next step and press reset button. Alarm light will continue to illuminate even if fault clears. To clear alarm, press reset button.

If the tower being regenerated fails to re-pressurize, the dryer will not switch towers. The switching failure alarm will be activated and the dryer will remain in this mode until the tower re-pressurizes.

8.2.5 Tower Status LEDs

Illuminated LEDs indicate which tower is on-line drying or off-line regenerating.

8.2.6 Tower Pressure Gauges

Periodically check tower pressure gauges to verify that the pressure gauge of the online tower reads line pressure and the pressure gauge of the offline tower reads below 2 psig (0.14 kgf/cm²).

NOTE: Read the offline tower pressure gauge when the tower is purging (air exhausting from muffler).

8.2.7 Check Mufflers For Back Pressure

Excessive back pressure may result due to the accumulation of desiccant fines (dust) in the muffler cartridges. This sometimes occurs after start-up due to dusting of the desiccant during tower filling and dryer transport. If the tower pressure gauge of the off-stream tower rises above 5 psig (3.5 kgf/cm²), the muffler elements should be replaced.

8.2.8 Process Valves

Determine if air control valves are operating and sequencing correctly.

Refer to Section 3.3 for a general description of operating sequence.

Refer to Tables 6-3 and 6-4 for time sequences for Standard Controllers. Refer to Tables 7-4 and 7-5 for time sequences for Energy Savings Controllers.

8.2.8.1 Valves

- Inlet/Outlet switching valves are non-lubricated shuttle valves. Pressure differences between the online and offline desiccant towers cause the shuttle valve to shift.
- Purge/repressurization valves are normally closed, pneumatically piston-actuated, Y-angle poppet valves. A yellow indicator can be seen through a clear window at the top of the actuator housing when the valve is in the open position.
- 12 volt DC, normally-closed, 3-way pilot solenoid valves are wired to the controller and are used to direct pilot air to the actuators of the purge/repressurization valves.
- Purge pressure and subsequent flow is adjusted by means of a quarter-turn ball valve located in the bypass line of the upper piping.
- Models are equipped with a single safety relief valve that has been sized at a minimum to provide overpressure protection due to a fire for both desiccant towers.

8.3 Operating Sequence

8.3.1 Operating sequence – Standard Controllers

The operating sequence for dryers equipped with Standard Controllers appears in Tables 6.3 and 6.4.

8.3.2 Operating sequence – Energy Savings Controllers

The operating sequence for dryers equipped with Energy Savings Controllers appears in Tables 7-2, 7-4, and 7-5.

8.4 Purifier Shut Down

- If the dryer installation is equipped with dryer bypass and inlet and outlet isolation valves, the bypass valve should be opened and the inlet and outlet isolation valves closed.
- De-pressurize the dryer by allowing the controller to run through tower change cycles until pressure gauges on both towers read zero. Manual test mode may be used to speed up this process. **NOTE:** Below 60 psig (4.22 kgf/cm²) purge/repressurization valves may not open. Opening the manual drain on the pilot air filter or any mounted pre or afterfilters may bleed off remaining pressure.
- Turn dryer off using on-off switch (indicating LEDs extinguished).

8.5 Loss of Power

Control valves are designed so that upon loss of power the air dryer is capable of drying air until the desiccant exposed to the airflow is saturated.

8.6 Operating Parameters

Verify that dryer is operating within the following design parameters:

8.6.1 Maximum Operating Pressure (MOP):

- 150 psig (10.5 kgf/cm²) is standard.
Refer to Dryer Serial Number Tag.

WARNING: Do not operate the dryer at pressures above the maximum operating pressure shown on the serial number tag.

NOTE: Consult factory for applications requiring higher maximum operating pressures.

8.6.2 Minimum Operating Pressures:

- 60 psig (4.2 kgf/cm²) is the minimum operating pressure
Refer to Dryer Serial Number Tag.

WARNING: Do not operate the dryer at pressures below the minimum operating pressure shown on the serial number tag.

NOTE: Consult factory for applications requiring lower minimum operating pressures.

8.6.3 Maximum Compressed Air Temperature at Dryer Inlet:

- 140°F (60°C) for all models.

8.6.4 Ambient Temperatures:

8.6.4.1 Minimum Ambient Temperature:

- Standard units: 35°F (2°C)
- Units with optional low ambient package: -20°F (-29°C)

8.6.4.2 Maximum Ambient Temperature:

- 120°F (49°C)

NOTE: If dryer is installed in ambients below 35°F (2°C), low ambient protection requiring heat tracing and insulation of the prefilter bowls, auto drains and/or sumps, and lower piping with inlet switching and purge/repressurization valves is necessary to prevent condensate from freezing. If installing heat tracing, observe electrical class code requirements for type of duty specified. Purge mufflers and their relief mechanisms must be kept clear from snow and ice buildup that could prevent proper discharge of compressed air.

8.7 Maximum Inlet Flow Capacity

- Refer to Table 8-1 for maximum inlet flow at rated conditions of 100 psig (7.0 kgf/cm²) and 100°F (38°C).
- At other conditions, multiply inlet flow from Table 8-1 by the multipliers from Tables 8-2 and 8-3 that correspond to the pressure and temperature at the inlet to the dryer.

8.8 Purge and Outlet Flows

8.8.1 Maximum Purge Flow

- Maximum Purge Flow is the amount of purge air flowing through the off-stream tower when the purge/repressurization valve is open. After the purge/repressurization valve closes, the purge flow will gradually decrease as the off-stream tower re-pressurizes to line pressure.
- For maximum purge flow multiply the Inlet Flow At Rated Conditions from Table 8-1 by Maximum Purge Flow Factor from Table 8-6 that corresponds to air pressure at inlet to dryer.
NOTE: For Energy Savings Controller equipped dryers supplied with the Automatic Purge Saving System operating in the Demand Cycle Mode, use ISO Class 2 (10 minutes) as the cycle time.

8.8.2 Average Purge Flow

- The Average Purge Flow is the actual amount of flow used during the entire purge/repressurization cycle. It includes the maximum purge flow for a portion of the purge/repressurization time and the volume of air used for repressurization, averaged over the cycle time.
- For average purge flow multiply the Inlet Flow At Rated Conditions from Table 8-1 by Average Purge/Repressurization Flow Factor from Table 8-7 that corresponds to the dryer MOP, Cycle Time Setting, Energy (purge) Savings % setting, and air pressure at inlet to dryer.

8.8.3 Minimum Outlet Air Flow

- Determine minimum outlet flow available from dryer by subtracting Maximum Purge Flow found above from inlet flow to the dryer.

8.8.4 Average Outlet Air Flow

- For dryers with Standard Controllers or Energy Savings Controllers operating in the fixed cycle mode, the average outlet flow available from dryer can be determined by subtracting the Average Maximum Purge Flow found above from the inlet flow to the dryer.

8.9 EXAMPLE

- Find the maximum inlet flow, maximum purge flow, and minimum outlet flow for a 60 SCFM unit operated with 120 psig and 100°F inlet conditions. Dryer will operate with an inlet airflow of 46 SCFM.
- Step 1: Find Maximum Inlet Flow at 120 psig by multiplying Maximum Inlet Flow at Rated Conditions from Table 8-1 by Inlet Pressure Correction Factor for 120 psig from Table 8-2 and Inlet Temperature from Table 8-3:
$$60 \times 1.08 \times 1.00 = 64.8 \text{ SCFM.}$$
- Step 2: Find Maximum Purge Flow by multiplying Maximum Inlet Flow at Rated Conditions from Table 8-1 by Maximum Purge Flow Factor from Table 8-5:
$$60 \times 0.162 = 9.7 \text{ SCFM.}$$
- Step 3: Find Minimum Outlet Flow available by subtracting Maximum Purge Flow (Step 2) from actual inlet flow:
$$46 - 9.7 = 36.3 \text{ SCFM.}$$

		MODEL									
		15	25	35	50	75	95	135	205	305	375
Inlet Flow	SCFM	18	30	42	60	90	114	162	246	366	450
	m ³ /hr	31	51	72	102	153	194	276	418	622	765
Outlet Flow	SCFM	15	25	35	50	75	95	135	205	305	375
	m ³ /hr	26	43	60	85	128	162	230	349	519	638

Table 8-1 Maximum Flow at Rated Conditions

INLET PRESSURE	psig	60	70	80	90	100	110	120	130	140	150	160	170	180	190	200	210	220	230	240	250
	kgf/cm ²	4.2	4.9	5.6	6.3	7.0	7.7	8.4	9.1	9.8	10.5	11.2	12.0	12.7	13.4	14.1	14.8	15.5	16.2	16.9	17.6
MULTIPLIER		0.65	0.74	0.83	0.91	1.00	1.04	1.08	1.12	1.16	1.20	1.23	1.27	1.30	1.34	1.37	1.40	1.43	1.46	1.49	1.52

Table 8-2 Inlet Pressure Correction Factors

INLET TEMPERATURE	°F	100 and below	105	110	115	120	125	130	135	140
	°C	38 and below	41	43	46	49	52	54	57	60
MULTIPLIER		1.00	0.98	0.96	0.93	0.89	0.85	0.81	0.76	0.70

Table 8-3 Inlet Temperature Correction Factor

DRYER MOP		150 psig (10.5 kgf/cm ²)						
INLET PRESSURE	psig	60-100	110	120	130	140	150	
	kgf/cm ²	4.2-7.0	7.7	8.4	9.1	9.8	10.5	
ISO CL.1	4 min.	psig	35	33	31	29	28	27
		kgf/cm ²	2.4	2.3	2.1	2.0	1.9	1.9
ISO CL.2	10 min.	psig	20	19	18	17	16	15
		kgf/cm ²	1.4	1.3	1.3	1.2	1.1	1.1

Table 8-4 Purge Pressure (NOTE: For units with the Energy Savings Controller operating in the Demand Cycle Mode, use the ISO Class 2 (10 min.) purge pressure settings only, regardless of ISO Class operating mode.)

INLET TEMPERATURE	°F	35	40	50	60	70	80	90	100	110	120
	°C	2	4	10	16	21	27	32	38	43	49
OUTLET P.D.P.	°F	-34	-28	-22	-16	-10	-4	3	9	15	21
	°C	-37	-33	-30	-27	-23	-20	-16	-13	-9	-6

Table 8-5 Outlet Pressure Dew points at Moisture Indicator Color Change

DRYER MOP		150 psig (10.5 kgf/cm ²)						
INLET PRESSURE	psig	60-100	110	120	130	140	150	
	kgf/cm ²	4.2-7.0	7.7	8.4	9.1	9.8	10.5	
ISO CL.1	4 min.	0.249	0.239	0.230	0.222	0.214	0.208	
ISO CL.2	10 min.	0.175	0.168	0.162	0.156	0.151	0.146	

Table 8-6 Maximum Purge Flow Factor

DRYER MOP	150 psig (10.5 kgf/cm ²)									
INLET PRESSURE (psig)	60	70	80	90	100	110	120	130	140	150
INLET PRESSURE (kg/cm ²)	4.2	4.9	5.6	6.3	7.0	7.7	8.4	9.1	9.8	10.5
ISO CLASS 1 4 MIN. CYCLE -100 °F / -73 °C PRESSURE DEWPOINT	0.147	0.149	0.151	0.153	0.155	0.151	0.148	0.145	0.143	0.141
ISO CLASS 2 10 MIN. CYCLE -40 °F / -40 °C PRESSURE DEWPOINT	0.141	0.142	0.143	0.143	0.144	0.139	0.135	0.131	0.128	0.125

Table 8-7 Average Purge / Repressurization Flow Factors (150 psig MOPs)

9.0 Maintenance

WARNING: The heatless desiccant dryer is a pressure-containing device. De-pressurize before servicing. (See Section 3.2)

NOTE: Standard and Energy Savings Controllers are equipped with Service Reminder functions for filters, desiccant and valves.

9.1 Shutdown

1. Close customer-supplied shutoff valve at purifier outlet.
2. Close customer-supplied shutoff valve at purifier inlet.
3. De-pressurize the dryer by allowing the controller to run through tower change cycles until pressure gauges on both towers read zero.

NOTE: Below 60 psig (4.22 kgf/cm²) purge/repressurization valves may not open. Opening the manual drain on the pilot air filter or any mounted pre or afterfilters may bleed off remaining pressure.

4. Turn off power switch on electrical box (indicating LEDs extinguished).

DANGER: Parts of a circuit may be energized when switch is off. Turn off switch and lock out power at main panel before servicing.

5. Close the manual drain on the pilot air filter or any mounted pre or afterfilters.

To restart, follow the Start-Up procedure.

9.2 Filtering/Purifying Media Replacement Intervals

9.2.1 Converter Cartridge

When indicated by the CO Monitoring system or after 4000 hours of service at full rated flow conditions. (Approximately six (6) months, not to exceed nine (9) months.)

NOTE: Unopened sealed replacement converter cartridges have a nominal shelf life of 2 years.

9.2.2 Desiccant Charge

When the indicator changes from green to yellow or after 8000 hours of service at full rated flow conditions. (Approximately one (1) year, not to exceed eighteen (18) months.)

NOTE: Only fresh dry desiccant should be used to replace spent desiccant charges.

9.2.3 Air Line Filter and Oil Removal Filter

When the differential pressure gauge indicates a pressure drop of 6 psi across the filter or after 4000 hours of service at full rated flow conditions. (Approximately six (6) months, not to exceed nine (9) months.)

9.2.4 Adsorbent (Oil Water Removal) Filter

When an odor is detected downstream of the Purifier or after 4000 hours of service at full rated flow conditions. (Approximately six (6) months, not to exceed nine (9) months.)

The adsorbent filter is provided with activated carbon which can remove organic gases and odor or taste causing materials. Its life and efficiency are dependent on the total air treated and the concentration of these impurities.

9.2.5 Humidity Indicator Cartridge Replacement

The change of color from green to yellow is reversible and replacement of the desiccant and converter charge will restore the original green color. If the indicator is yellow initially, the green color will be restored within a few minutes after placing the Purifier in operation. Do not operate the Purifier for breathing application until the upper indicator band is green.

It is recommended that the humidity indicator be replaced or rebuilt after 8000 hours of service at full rated flow conditions. (Approximately one (1) year, not to exceed eighteen (18) months.)

9.3 Desiccant Replacement

NOTE: The use of the correct replacement desiccant is necessary for proper dryer operation. Never use hygroscopic salts of the type commonly used in "deliquescent" type dryers.

9.3.1 Frequency Of Desiccant Replacement

Desiccant should be replaced whenever the required dew point cannot be maintained while the dryer is being operated within its design conditions and there are no mechanical malfunctions. Refer to section 10.0 for troubleshooting hints.

NOTE: Desiccant life is determined by the quality of the inlet air. Proper filtering of the inlet air will extend the life of the desiccant.

9.3.2 Procedure for Desiccant Charge Replacement

- De-pressurize and de-energize the dryer.
- Remove the fill and drain plugs from desiccant tower and drain the spent desiccant. Place a container at the base of the vessel to collect the desiccant. If necessary tap the sides of the vessels with a rubber mallet to loosen desiccant.

NOTE: Use extreme care when inserting rods or other tools through the desiccant fill or drain ports to loosen packed desiccant. Internal flow diffusers at the ends of the desiccant beds can be damaged or punctured by sharp instruments. These diffusers are necessary to distribute the airflow and keep the desiccant beads within the tower. Desiccant beads in exhaust mufflers, afterfilters, or the piping connected to the desiccant towers may indicate a perforation of a diffuser.

- Amount of desiccant required for complete change.

MODELS	DESICCANT REQUIRED (Quantity per Tower)	
	lbs.	(kgs)
CBA15	26	(11.8)
CBA25	26	(11.8)
CBA35	26	(11.8)
CBA50	40	(18.1)
CBA75	55	(24.9)
CBA95	105	(47.6)
CBA135	105	(47.6)
CBA205	159	(72.1)
CBA305	229	(103.9)
CBA375	271	(122.9)

- Replace the drain plug using Teflon tape or another pipe thread sealant suitable for compressed air service.
- Fill the desiccant tower with the required quantity of dry desiccant. Do not tamp or otherwise pack the desiccant.
- Replace the fill plug using Teflon tape or another pipe thread sealant suitable for compressed air service.
- Repeat this procedure for the other tower.

9.3.3 Ensuring Desiccant Dryness

Replacement desiccant is shipped in airtight containers. Keep the covers on these containers tightly closed until use to avoid moisture contamination. If desiccant is exposed to air it can be heated in an oven at 400°F (204°C) for four hours before use. Alternatively, if the dryer is not refilled with dry desiccant, it may be necessary to operate the unit with an inlet flow rate of less than 50% of maximum rated inlet capacity until the desiccant has regenerated fully.

9.4 CC Cartridge Replacement.

- **WARNING:** Do not attempt to refill spent cartridge with catalyst. Failure to replace spent cartridge with new cartridge provided by original supplier may result in serious personal injury. Supplier bears no responsibility for the consequences of the use of equipment in which non-approved replacement procedures are utilized.
- De-pressurize and de-energize the dryer.
- Loosen the unions or grooved couplings above and below the cartridge.
- Loosen the bracket(s) surrounding the cartridge and remove cartridge.
- Install new cartridge and retighten appropriate unions, couplings, and/or brackets.
- **NOTE:** Due to the weight of the CC cartridges, a mechanical lifting device is recommended for assistance in removing spent cartridges and installing new ones.

9.5 Procedure for Filter Element Replacement

- **WARNING: THIS FILTER IS A PRESSURE CONTAINING DEVICE. DEPRESSURIZE BEFORE SERVICING.** If filter has not been depressurized before disassembly, an audible alarm will sound when the bowl begins to be removed from the head. If this occurs, stop disassembly, isolate and completely depressurize filter before proceeding.

9.5.1 Removable bowl type filters

- Isolate filter (close inlet and outlet valves if installed) or shut off air supply.
- Depressurize filter by slowly opening manual drain valve.
- Remove bowl
Unscrew the bowl from the filter head using hand, strap wrench or C spanner. Pull bowl straight down.
- Clean filter bowl
- Replace element
 - a. Replacing complete element
 - 1) Pull off old element and discard.
 - 2) Make certain that the old and new element have the same part number and the end caps are the same color.
 - 3) Wipe the wall inside the filter head to remove any dirt.
 - 4) Lubricate the new element o-ring on the element top cap.
 - 5) Align the slot in the element top cap with the projection inside the filter head.

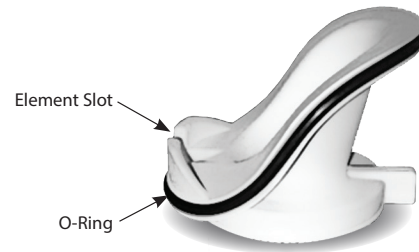
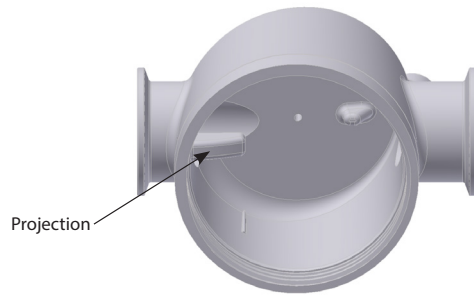

Figure 9-1

- 6) Insert the element into the head making sure the element slot and the projection inside the filter head remain aligned.

NOTE: Handle all elements by bottom end cap only.

- Replace housing o-ring (located at the top of the filter bowl) if needed. Make certain o-ring is generously lubricated (Use lubricant provided).
- Reassemble bowl to head.

NOTE: Threaded bowl to head connection, generously lubricate threads with a high grade/temperature lubricant good for 150°F, 66°C. (use lubricant provided).

9.5.2 Auto Drain Mechanism

It is recommended that drain mechanism be replaced or rebuilt after 4000 hours of service at full rated flow conditions. (Approximately six (6) months, not to exceed nine (9) months.)

9.6 Humidity Indicator Cartridge Replacement Procedure - All Models

- Depressurize and de-energize the Purifier.
- With indicator still installed, unscrew combination bleed and check valve assembly from indicator housing.
- Remove lower gasket and old indicator cartridge.
- Replace upper gasket and check to ensure that it is properly seated in housing.
- Install new indicator cartridge in housing so that thinner band of colored granules (indicator gel) is at the top.
- Insert new lower gasket.
- Screw the combination bleed and check valve assembly back into indicator housing.
- Re-pressurize and re-energize Purifier.

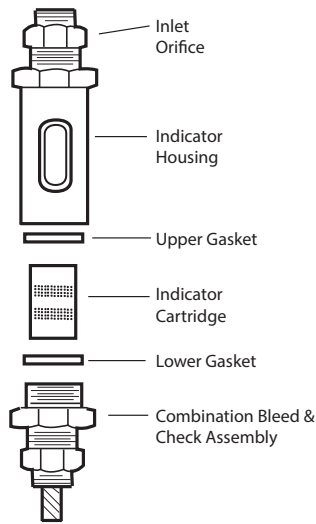

Figure 9-2
Humidity Indicator

9.7 Purge Mufflers

- Purge mufflers should be checked regularly, changed after 4000 hours of service at full rated flow conditions. (Approximately six (6) months, not to exceed nine (9) months.) Muffler disseminator elements become clogged with desiccant dust over time, creating back pressure and restricted purge flow.
- Refer to section 8.2.7.

9.8 Valves

- Process and pilot valves should be checked frequently for leaks and proper operation.
- Purge pressure adjustment valve should be checked frequently for proper adjustment.
- It is recommended that valves be replaced or rebuilt after 16,000 hours of service at full rated flow conditions. (Approximately two (2) years, not to exceed three (3) years.)
- Refer to section 8.2.8.

9.9 Pilot Air Filter Element Replacement

9.9.1 Frequency of replacement

The pilot air filter contains a filter element that should be changed after 4000 hours of service at full rated flow conditions. (Approximately six (6) months, not to exceed nine (9) months.) Replacement may be required sooner if pressure drop across cartridge prevents valves from actuating properly. Pilot air pressure should be in the range of 60-120 psig (4.2-8.4 kgf/cm²) and is controlled by a pressure regulator that has been set and sealed at 120 psig (8.4 kgf/cm²).

WARNING: The pilot air filter housing is a pressure-containing device, de-pressurize before servicing. Slowly open manual drain valve on bottom of filter bowl by turning clockwise to verify that the housing is de-pressurized before removing bowl.

9.9.2 Procedure for element replacement

- Isolate dryer from air supply
- De-pressurize dryer by running dryer and allowing system pressure to purge to atmosphere. Loss of pilot pressure will eventually prevent purge/repressurization valves from opening. Remaining pressure can be vented to atmosphere through the manual vent on the pilot air filter. The system must be fully de-pressurized before removing the bowl.
- Remove bowl
 - Unscrew the bowl from the filter head using hand, strap wrench or C spanner. Pull bowl straight down.
- Clean filter bowl
- Replace element
 - a. Replacing complete element
 - 1) Pull off old element and discard.
 - 2) Make certain that the old and new element have the same part number and the end caps are the same color.
 - 3) Wipe the wall inside the filter head to remove any dirt.
 - 4) Lubricate the new element o-ring on the element top cap.
 - 5) Align the slot in the element top cap with the projection inside the filter head.

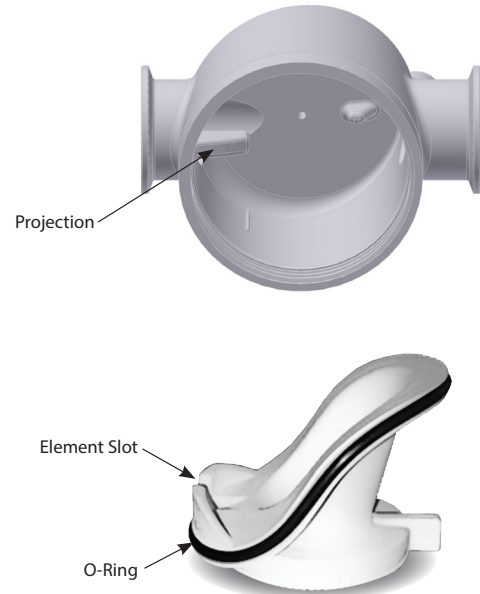

Figure 9-3

- 6) Insert the element into the head making sure the element slot and the projection inside the filter head remain aligned.

NOTE: Handle all elements by bottom end cap only.

- Replace housing o-ring (located at the top of the filter bowl) if needed. Make certain o-ring is generously lubricated (Use lubricant provided).
- Reassemble bowl to head.

NOTE: Threaded bowl to head connection, generously lubricate threads with a high grade/temperature lubricant good for 150°F, 66°C. (use lubricant provided).

10.0 Troubleshooting

SYMPTOM	POSSIBLE CAUSE(S)	CORRECTIVE ACTION
10.1 Indicator lights not illuminated	No power to unit.	Check voltage at terminal board.
	Off/On switch turned off.	Turn on.
	Blown fuse.	Replace fuse.
	Off/on switch or board malfunction.	Replace board.
10.2 Moisture indicator turns yellow (elevated outlet dew point)	Design conditions exceeded.	Refer to Sections 4 & 8 to determine if dryer is being outside of design limitations.
	Spent desiccant (useful service life has ended).	Replace desiccant.
	Contaminated desiccant (e.g. with oil)	Take corrective action. Refer to Section 4.1 to determine proper prefiltration before changing desiccant.
	Saturated desiccant (saturated with water)	Refer to 10.3 for corrective action. Operation at reduced flow may reactivate desiccant beds until desired outlet dew point is achieved.
10.3 Premature saturation of desiccant	Insufficient purge flow - Purge pressure too low	Refer to Section 8 to determine correct Purge Pressure Indicator setting.
	Incomplete tower depressurization (tower pressure greater than 2 psig) - clogged mufflers	Replace muffler inserts.
	Incomplete tower depressurization - Purge/repressurization valve fails to open	Verify voltage to pilot solenoid valve. Check pilot air pressure (60-120 psig required). Verify proper actuator operation.
	Insufficient purge time - Incorrect controller settings	Refer to Section 6 or 7 to determine correct controller cycle settings.
	Insufficient purge time - Faulty controller	Refer to Section 6 or 7 to verify proper time sequence. Replace controller board as required.
10.4 Tower fails to repressurize to line pressure	Purge/repressurization valve fails to close (air loss from mufflers during tower repressurization portion of cycle)	Verify removal of voltage to pilot solenoid valve. Verify proper actuator operation. This is a spring-assisted, normally closed valve. Check valve for obstruction or seat damage.
	Insufficient purge flow - Purge pressure too low	Refer to Section 8 to determine correct Purge Pressure Indicator setting . Purge Pressure Adjustment Valve should never be completely closed.
10.5 Excessive purge is discharged during purge cycle	Excessive purge flow - Purge pressure too high	Refer to Section 8 to determine correct Purge Pressure Indicator setting .
10.6 Excessive desiccant dust downstream	Fluidization of desiccant bed - design conditions for maximum rated flow exceeded	Refer to Section 4 or 8 to determine if dryer is being operated outside of design limitations.
	Fluidization of desiccant bed - Rapid repressurization of offstream tower due to: Faulty timer	Refer to Section 6 or 7 to verify proper time sequence.
	Insufficient purge flow - purge pressure too low	Refer to Section 8 to determine correct Purge Pressure Indicator setting .
10.7 Switching Failure Alarm	Faulty pressure switches or control board	Replace components
	Offstream tower did not de-pressurize in time and/or below 10 psig	Check mufflers, check or shuttle valve(s), inlet switching and purge/repressurization valves, purge pressure adjustment, and controller settings.
	Offstream tower did not re-pressurize in time and/or above 10 psig	Check air supply to dryer, purge/repressurization valve, purge pressure adjustment, and controller settings.

11.0 Notes

Information from the dryer serial number tag can be recorded in the following table. This information may be necessary when communicating with Service representatives.

Serial Number Tag Fields	Allowable Values from Serial Number Tag	Actual Values at Installation
Model Number:		
Serial Number:		
Service Code:		
Rated Capacity:		
Maximum Operating Temperature:		
Desiccant Type:		
VAC (AC Voltage):		
AC Phase:		
AC Frequency:		
AC Wattage:		
AC Holding Current:		
VDC (DC Voltage)		
DC Wattage:		
DC Holding Current:		
ETO DCF- Code (If Listed, Btm RH Corner)		
EC- Code (If Listed, Btm RH Corner)		

Additional information that may be useful when dealing with Service:

Location of installation (address and phone number): _____

Distributor purchased from: _____

Repair Parts List Number and Revision: _____

Indoors or outdoors installation: _____

Ambient temperature range: _____

Prefilters: _____

Drains: _____

Delta-P devices: _____

Afterfilters: _____

Delta-P devices: _____

Blocking or Isolation Valves: _____

ISO Class Operating Mode: _____

Fixed or Demand Cycle Mode (Energy Savings Controller only): _____

Outlet pressure dew point reading: _____

Additional accessories or special features: _____

12.0 Replacement Parts

Models 15 through 135

(continued on next page)

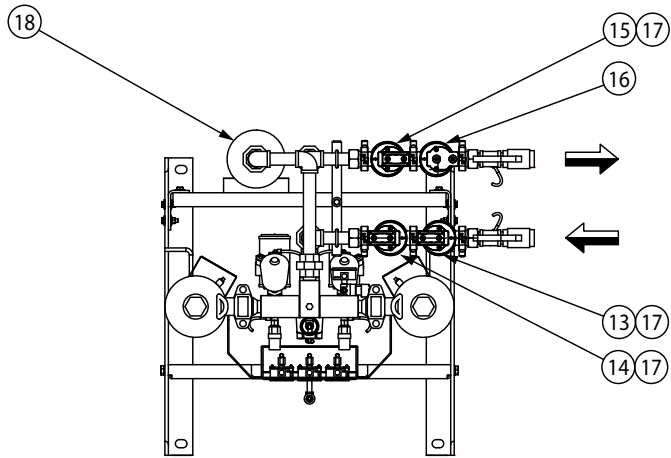

TOP VIEW

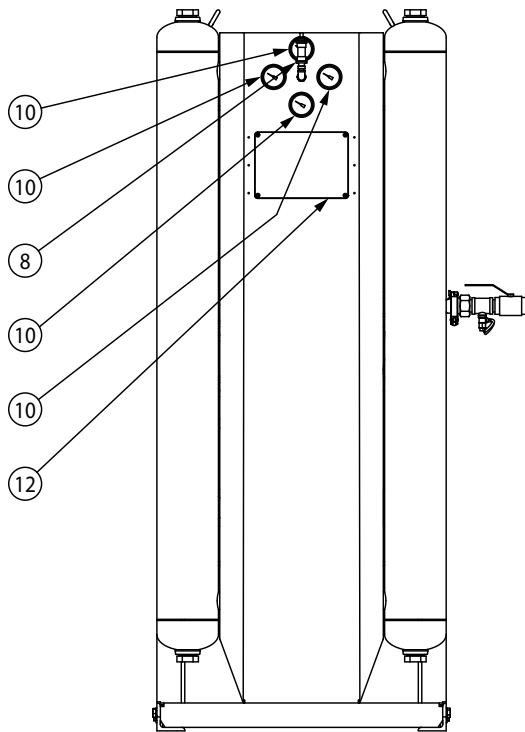

FRONT VIEW

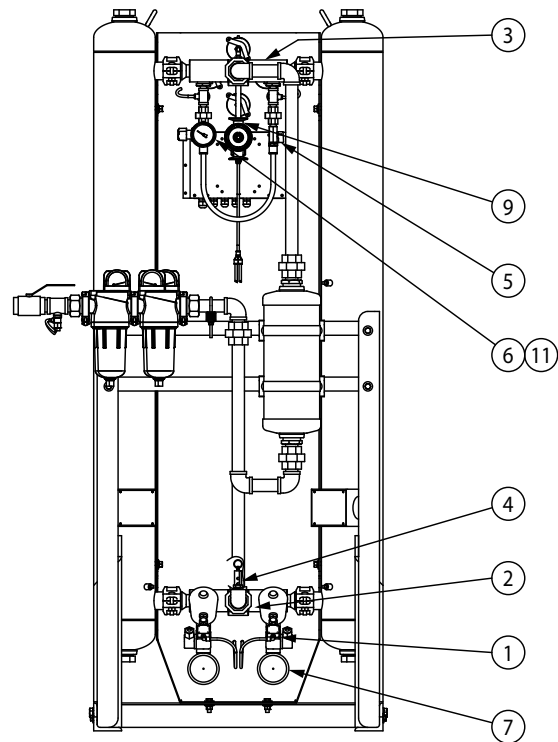

REAR VIEW

Phone: +1 724 745 1555
Email: ft.dehydration.order.entry@spxflow.com
Web: www.spxflow.com/hankison

Models 15 through 135

(continued from previous page)

REPLACEMENT PARTS			MODEL						SAFETY STOCK	DRYER QTY.	
ID#	P&ID#	DESCRIPTION	15	25	35	50	75	95			135
1	18	Purge/Repressurization Valve Assembly	7438612	7438612	7438612	7438613	7438613	7438614	7438614	1	2
*	5	Pilot Valve (with coil) 12 VDC	3203652	3203652	3203652	3203652	3203652	3203652	3203652	1	2
2	1	Inlet Shuttle Valve	3206222	3206222	3206222	3206222	3206222	3206222	3206222	—	1
3	2	Outlet Shuttle Valve	3206222	3206222	3206222	3206222	3206222	3206222	3206222	—	1
*	*	Shuttle Valve Repair Kit (Inlet/Outlet)	3214129	3214129	3214129	3214129	3214129	3214129	3214129	2	—
4	7	Pressure Relief Valve	7473401	7473401	7473401	7473401	7473401	7473401	7473401	—	1
5	3	Adjustable Purge Rate Valve	4009893	4009893	4009893	4009893	4009893	4009893	4009893	—	1
6	17	Purge Gauge Pressure Regulator	3204277	3204277	3204277	3204277	3204277	3204277	3204277	—	1
7	6	Purge Muffler	3133635	3133635	3133635	3071392	3071392	3090655	3090655	—	2
*	*	Muffler Insert	3075949	3075949	3075949	3107791	3107791	3126761	3126761	2	2
*	9	Purge Orifice	3060296	3117558	3086704	3055958	3060376	3109995	3161996	—	2
8	11	Moisture Indicator	4003168	4003168	4003168	4003168	4003168	4003168	4003168	—	1
		Moisture Indicator Repair Kit	3154165	3154165	3154165	3154165	3154165	3154165	3154165	1	—
9	16	Pilot Air Filter Replacement Cartridge (PF-02)	5005521	5005521	5005521	5005521	5005521	5005521	5005521	1	1
10	8	Tower Pressure Gauge	7417542	7417542	7417542	7417542	7417542	7417542	7417542	1	2
10	8	Tower Pressure Gauge (SST)	7450562	7450562	7450562	7450562	7450562	7450562	7450562	1	2
10	12	Inlet Pressure Gauge	7417542	7417542	7417542	7417542	7417542	7417542	7417542	—	1
10	12	Inlet Pressure Gauge (SST)	7450562	7450562	7450562	7450562	7450562	7450562	7450562	—	1
10	13	Outlet Pressure Gauge	7417542	7417542	7417542	7417542	7417542	7417542	7417542	—	1
10	13	Outlet Pressure Gauge (SST)	7450562	7450562	7450562	7450562	7450562	7450562	7450562	—	1
11	4	Purge Gauge	7450554	7450554	7450554	7450554	7450554	7450554	7450554	—	1
11	4	Purge Gauge (SST)	7450568	7450568	7450568	7450568	7450568	7450568	7450568	—	1
*	10	Pressure Switch	4006380	4006380	4006380	4006380	4006380	4006380	4006380	1	2
12	*	Standard Controller	3211224	3211224	3211224	3211224	3211224	3211224	3211224	—	1
12	*	Energy Savings Controller	3211233	3211233	3211233	3211233	3211233	3211233	3211233	—	1
*	15	Thermistor (Energy Savings Controller)	4011143	4011143	4011143	4011143	4011143	4011143	4011143	1	4
*	26	Inlet Low Pressure Switch (Energy Savings Controller)	3215749	3215749	3215749	3215749	3215749	3215749	3215749	—	1
*	27	Inlet High Temperature Switch (Energy Savings Controller)	3215750	3215750	3215750	3215750	3215750	3215750	3215750	—	1
13	21	General Purpose Prefilter Replacement Cartridge	5005521 PF-02	5005522 PF-03	5005523 PF-04	5006600 PF-06	5005524 PF-07	5005525 PF-08	5005526 PF-10	1	1
14	21A	High Efficiency Oil Removal Filter Replacement Cartridge	5005155 UF-02	5005156 UF-03	5005157 UF-04	5006584 UF-06	5005158 UF-07	5005159 UF-08	5005160 UF-10	1	1
15	22	General Purpose Afterfilter Replacement Cartridge	5005521 PF-02	5005522 PF-03	5005523 PF-04	5006600 PF-06	5005524 PF-07	5005525 PF-08	5005526 PF-10	1	1
16	22A	Oil Removal Filter Replacement Cartridge	5005196 CF-02	5005197 CF-03	5005198 CF-04	5006590 CF-06	5005199 CF-07	5005200 CF-08	5005421 CF-10	1	1
17	23	Filter Differential Pressure Gauge	5006606	5006606	5006606	5006606	5006606	5006606	5006606	1	3
18	*	Replacement Catalyst Cartridge	3209887 CC0	3209887 CC0	3209887 CC0	3209233 CC1	3209233 CC1	3209238 CC2	3209238 CC2	—	1
Replacement Desiccant			3254720	3254720	3254720	3254721	3254750	3254752	3254752		
Desiccant Evaluation Kit			7452585	7452585	7452585	7452585	7452585	7452585	7452585		

NOTES:

1. Parts are for standard builds only. Please contact the factory with your dryer serial number for assistance on identifying spare parts for your specific unit.
2. All quantities for one dryer.
3. ID# correspond to P&ID legend located on page 55 (* Not pictured in diagram and/or identified on P&ID.)

Phone: +1 724 745 1555
 Email: ft.dehydration.order.entry@spxflow.com
 Web: www.spxflow.com/hankison

Models 205 through 375

(continued on next page)

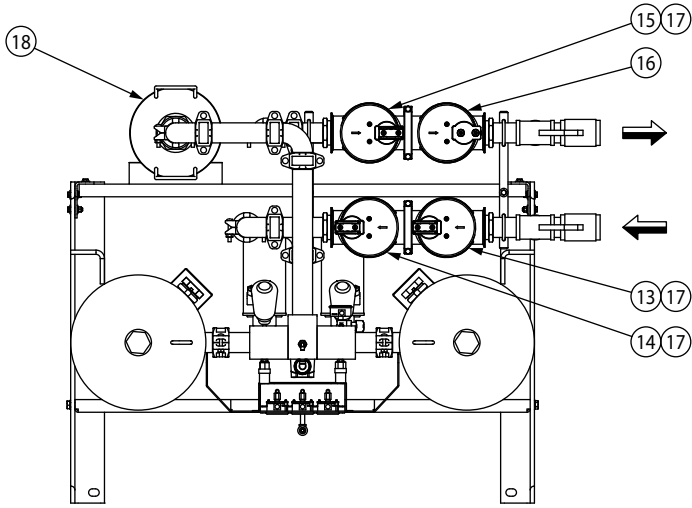

TOP VIEW

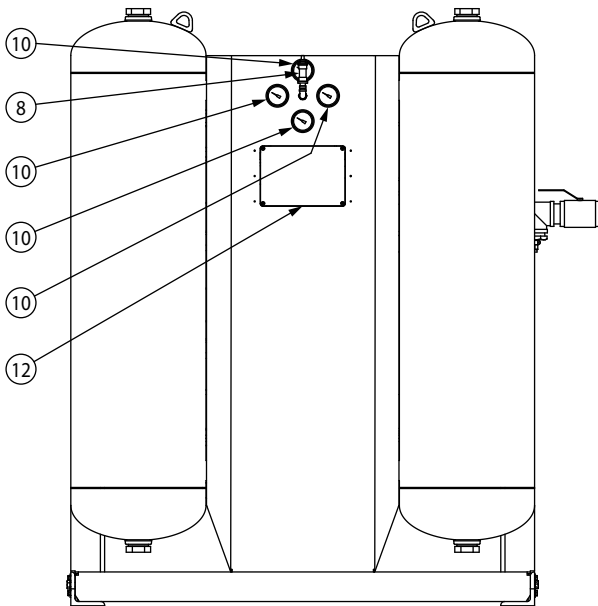

FRONT VIEW

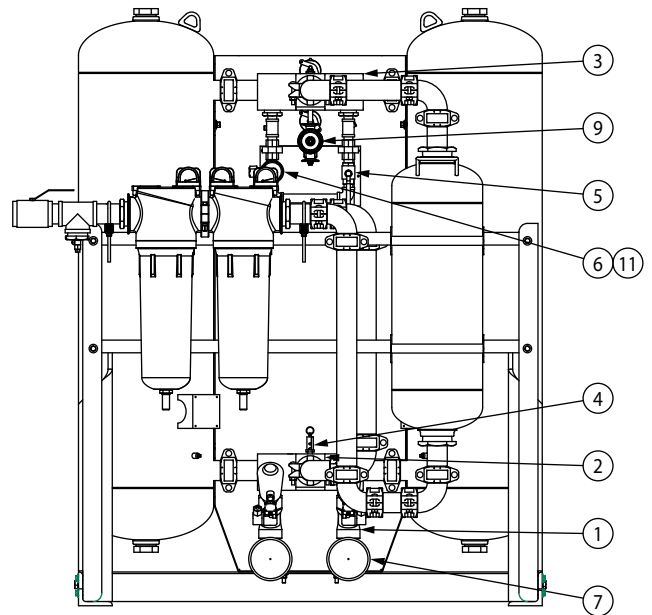

REAR VIEW

Phone: +1 724 745 1555
Email: ft.dehydration.order.entry@spxflow.com
Web: www.spxflow.com/hankison

Models 205 through 375

(continued from previous page)

REPLACEMENT PARTS			MODEL			SAFETY STOCK	DRYER QTY.
ID#	P&ID	DESCRIPTION	205	305	375		
1	18	Purge/Repressurization Valve Assembly	7438616	7438616	7438616	1	2
*	5	Pilot Valve for NEMA 4, 4X (Valve with coil)	3203652	3203652	3203652	1	2
2	1	Inlet Shuttle Valve	3206223	3206223	3206223	—	1
3	2	Outlet Shuttle Valve	3206223	3206223	3206223	—	1
		Shuttle Valve Repair Kit (Inlet/Outlet)	3260109	3260109	3260109	2	—
4	7	Pressure Relief Valve	7473402	7473402	7473402	—	1
5	3	Adjustable Purge Rate Valve	4009894	4009895	4009895	—	1
6	17	Purge Gauge Pressure Regulator	3204277	3204277	3204277	—	1
7	6	Purge Muffler	3130773	3130773	3130773	—	2
*	*	Muffler Insert	3121200	3121200	3121200	2	2
*	9	Purge Orifice	3162102	1268393	3161907	—	2
8	11	Moisture Indicator	4003168	4003168	4003168	—	1
		Moisture Indicator Repair Kit	3154165	3154165	3154165	1	—
9	16	Pilot Air Filter Replacement Cartridge (PF-02)	5005521	5005521	5005521	1	1
10	8	Tower Pressure Gauge	7417542	7417542	7417542	1	2
10	8	Tower Pressure Gauge (SST)	7450562	7450562	7450562	1	2
10	12	Inlet Pressure Gauge	7417542	7417542	7417542	—	1
10	12	Inlet Pressure Gauge (SST)	7450562	7450562	7450562	—	1
10	13	Outlet Pressure Gauge	7417542	7417542	7417542	—	1
10	13	Outlet Pressure Gauge (SST)	7450562	7450562	7450562	—	1
11	4	Purge Gauge	7450554	7450554	7450554	—	1
11	4	Purge Gauge (SST)	7450568	7450568	7450568	—	1
*	10	Pressure Switch	4006380	4006380	4006380	1	2
12		Standard Controller	3211224	3211224	3211224	—	1
12		Energy Savings Controller	3211233	3211233	3211233	—	1
*	15	Thermistor (Energy Savings Controller)	4011143	4011143	4011143	1	4
*	26	Inlet Low Pressure Switch (Energy Savings Controller)	3215749	3215749	3215749	—	1
*	27	Inlet High Temperature Switch (Energy Savings Controller)	3215750	3215750	3215750	—	1
13	21	General Purpose Prefilter Replacement Cartridge	5005526 PF-10	5005528 PF-12	7404429 PF-13	1	1
14	21A	High Efficiency Oil Removal Filter Replacement Cartridge	5005160 UF-10	5005162 UF-12	7404423 UF-13	1	1
15	22	General Purpose Afterfilter Replacement Cartridge	5005526 PF-10	5005528 PF-12	7404429 PF-13	1	1
16	22A	Oil Removal Filter Replacement Cartridge	5005421 CF-10	5005423 CF-12	7404432 CF-13	1	1
17	23	Filter Differential Pressure Gauge	5006606	5006606	5006606	1	3
18	*	Replacement Catalyst Cartridge	3209389 CC3	3209410 CC4	3209448 CC5	—	1
		Replacement Desiccant	3254753	3254754	3254755		
		Desiccant Evaluation Kit	7452585	7452585	7452585		

NOTES:

1. Parts and Maintenance Kits are for standard builds only. Please contact the factory with your dryer serial number for assistance on identifying spare parts and maintenance kits for your specific unit.
2. All quantities for one dryer.
3. ID# correspond to P&ID legend located on page 55 (* Not pictured in diagram and/or identified on P&ID.)

Phone: +1 724 745 1555
 Email: ft.dehydration.order.entry@spxflow.com
 Web: www.spxflow.com/hankison

13.0 Maintenance Kits

Models 15 through 75

(continued on next page)

MODEL				
15	25	35	50	75

MAINTENANCE KITS

4000 Hour Maintenance Kit	Filter Elements, Converter Cartridge, Pilot Air Filter Cartridge, Filter Housing O-Rings, Muffler Cores, Drain	CBA15MK-4K-NGF (7435162)	CBA25MK-4K-NGF (7435163)	CBA35MK-4K-NGF (7435164)	CBA50MK-4K-NGF (7435165)	CBA75MK-4K-NGF (7435172)
8000 Hour Maintenance Kit	All the contents of the 4000 Hour Kit, Moisture Indicator, Desiccant Kit	CBA15MK-8K-S-NGF (7435182)	CBA25MK-8K-S-NGF (7435183)	CBA35MK-8K-S-NGF (7435184)	CBA50MK-8K-S-NGF (7435185)	CBA75MK-8K-S-NGF (7435186)
12000 Hour Maintenance Kit	Filter Elements, Converter Cartridge, Pilot Air Filter Cartridge, Filter Housing O-Rings, Muffler Cores, Drain	CBA15MK-4K-NGF (7435162)	CBA25MK-4K-NGF (7435163)	CBA35MK-4K-NGF (7435164)	CBA50MK-4K-NGF (7435165)	CBA75MK-4K-NGF (7435172)
16000 Hour Maintenance Kit	All the contents of the 8000 Hour Kit, Pressure Switches, Valve Repair Kits	CBA15MK-16K-S-NGF (7435197)	CBA25MK-16K-S-NGF (7435198)	CBA35MK-16K-S-NGF (7435199)	CBA50MK-16K-S-NGF (7435200)	CBA75MK-16K-S-NGF (7435201)

CO Option (AZ1)

4000 Hour Maintenance Kit	Filter Elements, Converter Cartridge, Pilot Air Filter Cartridge, Filter Housing O-Rings, Muffler Cores, Drain	CBA15MK-4K-NGF (7435162)	CBA25MK-4K-NGF (7435163)	CBA35MK-4K-NGF (7435164)	CBA50MK-4K-NGF (7435165)	CBA75MK-4K-NGF (7435172)
8000 Hour Maintenance Kit	All the contents of the 4000 Hour Kit, CO Monitor Calibration & Sensor Kits, Moisture Indicator, Desiccant Kit	CBA15MK-8K-AZ1-NGF (7478796)	CBA25MK-8K-AZ1-NGF (7478797)	CBA35MK-8K-AZ1-NGF (7478798)	CBA50MK-8K-AZ1-NGF (7478799)	CBA75MK-8K-AZ1-NGF (7478800)
12000 Hour Maintenance Kit	Filter Elements, Converter Cartridge, Pilot Air Filter Cartridge, Filter Housing O-Rings, Muffler Cores, Drain	CBA15MK-4K-NGF (7435162)	CBA25MK-4K-NGF (7435163)	CBA35MK-4K-NGF (7435164)	CBA50MK-4K-NGF (7435165)	CBA75MK-4K-NGF (7435172)
16000 Hour Maintenance Kit	All the contents of the 8000 Hour Kit, Pressure Switches, Valve Repair Kits	CBA15MK-16K-AZ1-NGF (7478810)	CBA25MK-16K-AZ1-NGF (7478811)	CBA35MK-16K-AZ1-NGF (7478812)	CBA50MK-16K-AZ1-NGF (7478813)	CBA75MK-16K-AZ1-NGF (7478814)

CO w/ O2 Option (AZ2)

4000 Hour Maintenance Kit	Filter Elements, Converter Cartridge, Pilot Air Filter Cartridge, Filter Housing O-Rings, Muffler Cores, Drain	CBA15MK-4K-NGF (7435162)	CBA25MK-4K-NGF (7435163)	CBA35MK-4K-NGF (7435164)	CBA50MK-4K-NGF (7435165)	CBA75MK-4K-NGF (7435172)
8000 Hour Maintenance Kit	All the contents of the 4000 Hour Kit, CO Monitor Calibration & Sensor Kits, Moisture Indicator, Desiccant Kit	CBA15MK-8K-AZ2-NGF (7435242)	CBA25MK-8K-AZ2-NGF (7435243)	CBA35MK-8K-AZ2-NGF (7435244)	CBA50MK-8K-AZ2-NGF (7435245)	CBA75MK-8K-AZ2-NGF (7435246)
12000 Hour Maintenance Kit	Filter Elements, Converter Cartridge, Pilot Air Filter Cartridge, Filter Housing O-Rings, Muffler Cores, Drain	CBA15MK-4K-NGF (7435162)	CBA25MK-4K-NGF (7435163)	CBA35MK-4K-NGF (7435164)	CBA50MK-4K-NGF (7435165)	CBA75MK-4K-NGF (7435172)
16000 Hour Maintenance Kit	All the contents of the 8000 Hour Kit, Pressure Switches, Valve Repair Kits	CBA15MK-16K-AZ2-NGF (7435256)	CBA25MK-16K-AZ2-NGF (7435257)	CBA35MK-16K-AZ2-NGF (7435258)	CBA50MK-16K-AZ2-NGF (7435259)	CBA75MK-16K-AZ2-NGF (7435260)

Phone: +1 724 745 1555
 Email: ft.dehydration.order.entry@spxflow.com
 Web: www.spxflow.com/hankison

Models 15 through 75

(continued from previous page)

		MODEL				
		15	25	35	50	75
CO w/ Dew Point Option (AZ3)						
4000 Hour Maintenance Kit	Filter Elements, Converter Cartridge, Pilot Air Filter Cartridge, Filter Housing O-Rings, Muffler Cores, Drain	CBA15MK-4K-NGF (7435162)	CBA25MK-4K-NGF (7435163)	CBA35MK-4K-NGF (7435164)	CBA50MK-4K-NGF (7435165)	CBA75MK-4K-NGF (7435172)
8000 Hour Maintenance Kit	All the contents of the 4000 Hour Kit, CO Monitor Calibration & Sensor Kits, Moisture Indicator, Desiccant Kit	CBA15MK-8K-AZ3-NGF (7435281)	CBA25MK-8K-AZ3-NGF (7435282)	CBA35MK-8K-AZ3-NGF (7435283)	CBA50MK-8K-AZ3-NGF (7435284)	CBA75MK-8K-AZ3-NGF (7435285)
12000 Hour Maintenance Kit	Filter Elements, Converter Cartridge, Pilot Air Filter Cartridge, Filter Housing O-Rings, Muffler Cores, Drain	CBA15MK-4K-NGF (7435162)	CBA25MK-4K-NGF (7435163)	CBA35MK-4K-NGF (7435164)	CBA50MK-4K-NGF (7435165)	CBA75MK-4K-NGF (7435172)
16000 Hour Maintenance Kit	All the contents of the 8000 Hour Kit, Pressure Switches, Valve Repair Kits	CBA15MK-16K-AZ3-NGF (7435295)	CBA25MK-16K-AZ3-NGF (7435296)	CBA35MK-16K-AZ3-NGF (7435297)	CBA50MK-16K-AZ3-NGF (7435298)	CBA75MK-16K-AZ3-NGF (7435299)

CO w/ O2 & Dew Point Option (AZ4)						
4000 Hour Maintenance Kit	Filter Elements, Converter Cartridge, Pilot Air Filter Cartridge, Filter Housing O-Rings, Muffler Cores, Drain	CBA15MK-4K-NGF (7435162)	CBA25MK-4K-NGF (7435163)	CBA35MK-4K-NGF (7435164)	CBA50MK-4K-NGF (7435165)	CBA75MK-4K-NGF (7435172)
8000 Hour Maintenance Kit	All the contents of the 4000 Hour Kit, CO Monitor Calibration & Sensor Kits, Moisture Indicator, Desiccant Kit	CBA15MK-8K-AZ4-NGF (7435309)	CBA25MK-8K-AZ4-NGF (7435310)	CBA35MK-8K-AZ4-NGF (7435311)	CBA50MK-8K-AZ4-NGF (7435312)	CBA75MK-8K-AZ4-NGF (7435313)
12000 Hour Maintenance Kit	Filter Elements, Converter Cartridge, Pilot Air Filter Cartridge, Filter Housing O-Rings, Muffler Cores, Drain	CBA15MK-4K-NGF (7435162)	CBA25MK-4K-NGF (7435163)	CBA35MK-4K-NGF (7435164)	CBA50MK-4K-NGF (7435165)	CBA75MK-4K-NGF (7435172)
16000 Hour Maintenance Kit	All the contents of the 8000 Hour Kit, Pressure Switches, Valve Repair Kits	CBA15MK-16K-AZ4-NGF (7435324)	CBA25MK-16K-AZ4-NGF (7435325)	CBA35MK-16K-AZ4-NGF (7435326)	CBA50MK-16K-AZ4-NGF (7435327)	CBA75MK-16K-AZ4-NGF (7435328)

Phone: +1 724 745 1555
 Email: ft.dehydration.order.entry@spxflow.com
 Web: www.spxflow.com/hankison

Models 95 through 375

(continued on next page)

MODEL				
95	135	205	305	375

MAINTENANCE KITS

Maintenance Kit	Description	95	135	205	305	375
4000 Hour Maintenance Kit	Filter Elements, Converter Cartridge, Pilot Air Filter Cartridge, Filter Housing O-Rings, Muffler Cores, Drain	CBA95MK-4K-NGF (7435173)	CBA135MK-4K-NGF (7435174)	CBA205MK-4K-NGF (7435175)	CBA305MK-4K-NGF (7435176)	CBA375MK-4K-NGF (7435177)
8000 Hour Maintenance Kit	All the contents of the 4000 Hour Kit, Moisture Indicator, Desiccant Kit	CBA95MK-8K-S-NGF (7435187)	CBA135MK-8K-S-NGF (7435188)	CBA205MK-8K-S-NGF (7435189)	CBA305MK-8K-S-NGF (7435190)	CBA375MK-8K-S-NGF (7435191)
12000 Hour Maintenance Kit	Filter Elements, Converter Cartridge, Pilot Air Filter Cartridge, Filter Housing O-Rings, Muffler Cores, Drain	CBA95MK-4K-NGF (7435173)	CBA135MK-4K-NGF (7435174)	CBA205MK-4K-NGF (7435175)	CBA305MK-4K-NGF (7435176)	CBA375MK-4K-NGF (7435177)
16000 Hour Maintenance Kit	All the contents of the 8000 Hour Kit, Pressure Switches, Valve Repair Kits	CBA95MK-16K-S-NGF (7435202)	CBA135MK-16K-S-NGF (7435203)	CBA205MK-16K-S-NGF (7435204)	CBA305MK-16K-S-NGF (7435205)	CBA375MK-16K-S-NGF (7435206)

CO Option (AZ1)

Maintenance Kit	Description	95	135	205	305	375
4000 Hour Maintenance Kit	Filter Elements, Converter Cartridge, Pilot Air Filter Cartridge, Filter Housing O-Rings, Muffler Cores, Drain	CBA95MK-4K-NGF (7435173)	CBA135MK-4K-NGF (7435174)	CBA205MK-4K-NGF (7435175)	CBA305MK-4K-NGF (7435176)	CBA375MK-4K-NGF (7435177)
8000 Hour Maintenance Kit	All the contents of the 4000 Hour Kit, CO Monitor Calibration & Sensor Kits, Moisture Indicator, Desiccant Kit	CBA95MK-8K-AZ1-NGF (7478801)	CBA135MK-8K-AZ1-NGF (7478802)	CBA205MK-8K-AZ1-NGF (7478803)	CBA305MK-8K-AZ1-NGF (7478804)	CBA375MK-8K-AZ1-NGF (7478805)
12000 Hour Maintenance Kit	Filter Elements, Converter Cartridge, Pilot Air Filter Cartridge, Filter Housing O-Rings, Muffler Cores, Drain	CBA95MK-4K-NGF (7435173)	CBA135MK-4K-NGF (7435174)	CBA205MK-4K-NGF (7435175)	CBA305MK-4K-NGF (7435176)	CBA375MK-4K-NGF (7435177)
16000 Hour Maintenance Kit	All the contents of the 8000 Hour Kit, Pressure Switches, Valve Repair Kits	CBA95MK-16K-AZ1-NGF (7478815)	CBA135MK-16K-AZ1-NGF (7478816)	CBA205MK-16K-AZ1-NGF (7478817)	CBA305MK-16K-AZ1-NGF (7478818)	CBA375MK-16K-AZ1-NGF (7478819)

CO w/ O2 Option (AZ2)

Maintenance Kit	Description	95	135	205	305	375
4000 Hour Maintenance Kit	Filter Elements, Converter Cartridge, Pilot Air Filter Cartridge, Filter Housing O-Rings, Muffler Cores, Drain	CBA95MK-4K-NGF (7435173)	CBA135MK-4K-NGF (7435174)	CBA205MK-4K-NGF (7435175)	CBA305MK-4K-NGF (7435176)	CBA375MK-4K-NGF (7435177)
8000 Hour Maintenance Kit	All the contents of the 4000 Hour Kit, CO Monitor Calibration & Sensor Kits, Moisture Indicator, Desiccant Kit	CBA95MK-8K-AZ2-NGF (7435247)	CBA135MK-8K-AZ2-NGF (7435248)	CBA205MK-8K-AZ2-NGF (7435249)	CBA305MK-8K-AZ2-NGF (7435250)	CBA375MK-8K-AZ2-NGF (7435251)
12000 Hour Maintenance Kit	Filter Elements, Converter Cartridge, Pilot Air Filter Cartridge, Filter Housing O-Rings, Muffler Cores, Drain	CBA95MK-4K-NGF (7435173)	CBA135MK-4K-NGF (7435174)	CBA205MK-4K-NGF (7435175)	CBA305MK-4K-NGF (7435176)	CBA375MK-4K-NGF (7435177)
16000 Hour Maintenance Kit	All the contents of the 8000 Hour Kit, Pressure Switches, Valve Repair Kits	CBA95MK-16K-AZ2-NGF (7435261)	CBA135MK-16K-AZ2-NGF (7435262)	CBA205MK-16K-AZ2-NGF (7435263)	CBA305MK-16K-AZ2-NGF (7435264)	CBA375MK-16K-AZ2-NGF (7435265)

Phone: +1 724 745 1555
 Email: ft.dehydration.order.entry@spxflow.com
 Web: www.spxflow.com/hankison

Models 95 through 375

(continued from previous page)

		MODEL				
		95	135	205	305	375
CO w/ Dew Point Option (AZ3)						
4000 Hour Maintenance Kit	Filter Elements, Converter Cartridge, Pilot Air Filter Cartridge, Filter Housing O-Rings, Muffler Cores, Drain	CBA95MK-4K-NGF (7435173)	CBA135MK-4K-NGF (7435174)	CBA205MK-4K-NGF (7435175)	CBA305MK-4K-NGF (7435176)	CBA375MK-4K-NGF (7435177)
8000 Hour Maintenance Kit	All the contents of the 4000 Hour Kit, CO Monitor Calibration & Sensor Kits, Moisture Indicator, Desiccant Kit	CBA95MK-8K-AZ3-NGF (7435286)	CBA135MK-8K-AZ3-NGF (7435287)	CBA205MK-8K-AZ3-NGF (7435288)	CBA305MK-8K-AZ3-NGF (7435289)	CBA375MK-8K-AZ3-NGF (7435290)
12000 Hour Maintenance Kit	Filter Elements, Converter Cartridge, Pilot Air Filter Cartridge, Filter Housing O-Rings, Muffler Cores, Drain	CBA95MK-4K-NGF (7435173)	CBA135MK-4K-NGF (7435174)	CBA205MK-4K-NGF (7435175)	CBA305MK-4K-NGF (7435176)	CBA375MK-4K-NGF (7435177)
16000 Hour Maintenance Kit	All the contents of the 8000 Hour Kit, Pressure Switches, Valve Repair Kits	CBA95MK-16K-AZ3-NGF (7435300)	CBA135MK-16K-AZ3-NGF (7435301)	CBA205MK-16K-AZ3-NGF (7435302)	CBA305MK-16K-AZ3-NGF (7435303)	CBA375MK-16K-AZ3-NGF (7435304)

CO w/ O2 & Dew Point Option (AZ4)						
4000 Hour Maintenance Kit	Filter Elements, Converter Cartridge, Pilot Air Filter Cartridge, Filter Housing O-Rings, Muffler Cores, Drain	CBA95MK-4K-NGF (7435173)	CBA135MK-4K-NGF (7435174)	CBA205MK-4K-NGF (7435175)	CBA305MK-4K-NGF (7435176)	CBA375MK-4K-NGF (7435177)
8000 Hour Maintenance Kit	All the contents of the 4000 Hour Kit, CO Monitor Calibration & Sensor Kits, Moisture Indicator, Desiccant Kit	CBA95MK-8K-AZ4-NGF (7435314)	CBA135MK-8K-AZ4-NGF (7435315)	CBA205MK-8K-AZ4-NGF (7435316)	CBA305MK-8K-AZ4-NGF (7435317)	CBA375MK-8K-AZ4-NGF (7435318)
12000 Hour Maintenance Kit	Filter Elements, Converter Cartridge, Pilot Air Filter Cartridge, Filter Housing O-Rings, Muffler Cores, Drain	CBA95MK-4K-NGF (7435173)	CBA135MK-4K-NGF (7435174)	CBA205MK-4K-NGF (7435175)	CBA305MK-4K-NGF (7435176)	CBA375MK-4K-NGF (7435177)
16000 Hour Maintenance Kit	All the contents of the 8000 Hour Kit, Pressure Switches, Valve Repair Kits	CBA95MK-16K-AZ4-NGF (7435329)	CBA135MK-16K-AZ4-NGF (7435330)	CBA205MK-16K-AZ4-NGF (7435331)	CBA305MK-16K-AZ4-NGF (7435332)	CBA375MK-16K-AZ4-NGF (7435333)

Phone: +1 724 745 1555
 Email: ft.dehydration.order.entry@spxflow.com
 Web: www.spxflow.com/hankison

14.0 Drawings

P&ID Drawing

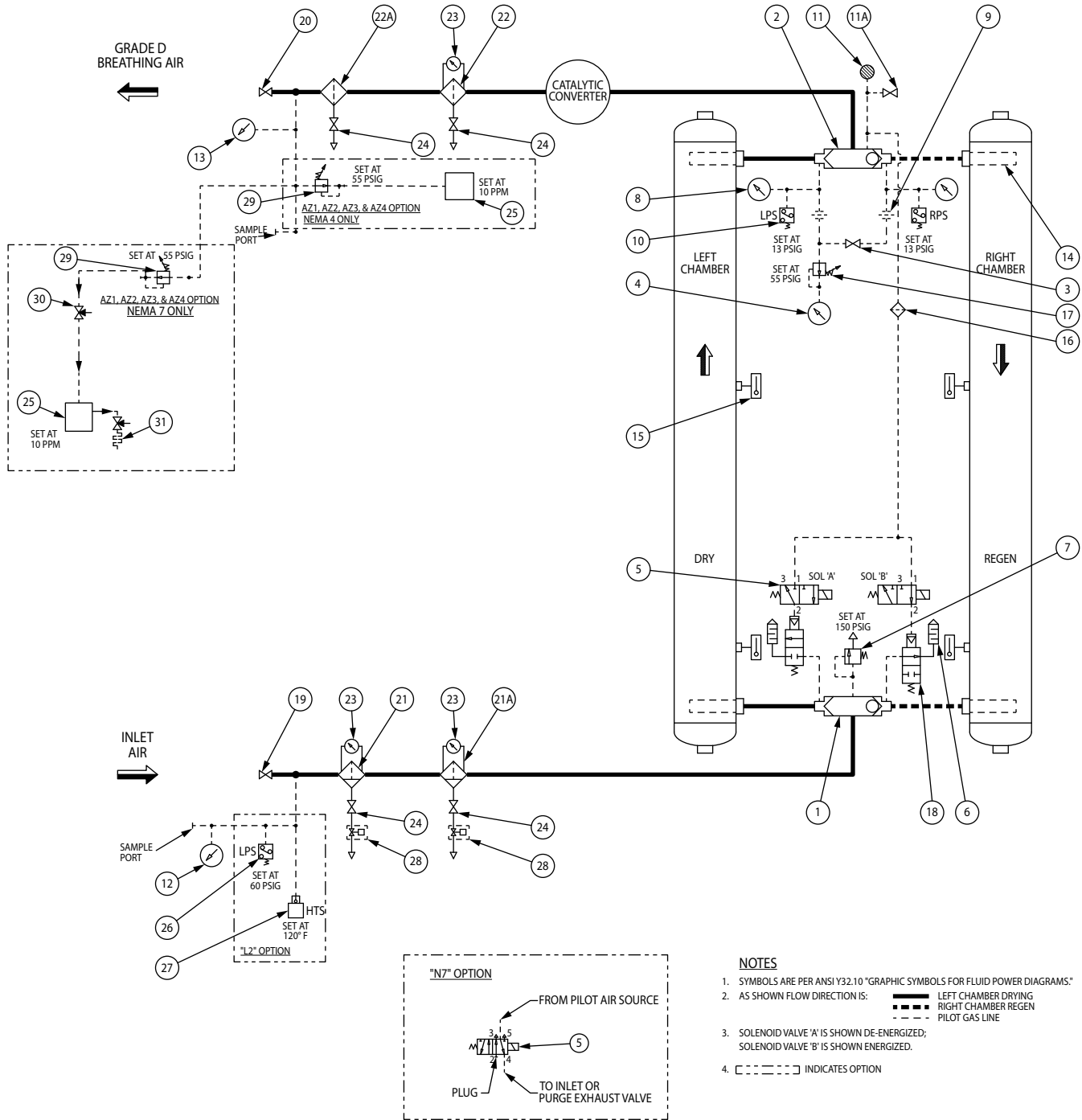

NOTES

1. SYMBOLS ARE PER ANSI Y32.10 "GRAPHIC SYMBOLS FOR FLUID POWER DIAGRAMS"
2. AS SHOWN FLOW DIRECTION IS:
 - LEFT CHAMBER DRYING
 - - - RIGHT CHAMBER REGEN
 - · · · · PILOT GAS LINE
3. SOLENOID VALVE 'A' IS SHOWN DE-ENERGIZED;
SOLENOID VALVE 'B' IS SHOWN ENERGIZED.
4. □ □ □ □ INDICATES OPTION

LEGEND

- 1. Inlet Shuttle Valve Assembly
- 2. Outlet Shuttle Valve Assembly
- 3. Purge Adjusting Valve
- 4. Purge Flow Indicator
- 5. Solenoid Valve
- 6. Muffler
- 7. Relief Valve
- 8. Chamber Pressure Gauge
- 9. Orifice
- 10. Pressure Switch
- 11. Moisture Indicator
- 11A. Bleed Valve
- 12. Inlet Pressure Gauge
- 13. Outlet Pressure Gauge
- 14. Bushing Screen
- 15. Sensatherm (Energy Savings Controller Option Only)
- 16. Pilot Gas Filter
- 17. Pressure Regulator
- 18. Purge Exhaust Valve
- 19. Inlet Shutoff Ball Valve
- 20. Outlet Shutoff Ball Valve
- 21. Prefilter - Air Line Filter
- 21A. Prefilter - High Efficiency Oil Removal Filter
- 22. Afterfilter - Dry Desiccant Afterfilter
- 22A. Afterfilter - Oil Removal Filter
- 23. Filter Differential Pressure Gauge
- 24. Service Valve
- 25. Carbon Monoxide Monitor
- 26. Inlet Low Pressure Switch (Energy Savings Controller Option)
- 27. Inlet High Temperature Switch (Energy Savings Controller Option)
- 28. Electric Drain Valve (Model 375 ONLY)
- 29. Pressure Regulator 55PSI Preset (AZ1, AZ2, AZ3, and AZ4 options)
- 30. Needle Valve (for AZ1, AZ2, AZ3, and AZ4 options in hazardous location)
- 31. Diffusion Coil (for AZ1, AZ2, AZ3, and AZ4 options in hazardous location)

Electrical Schematic For Mounted Multi-Function Monitor in Hazardous Location

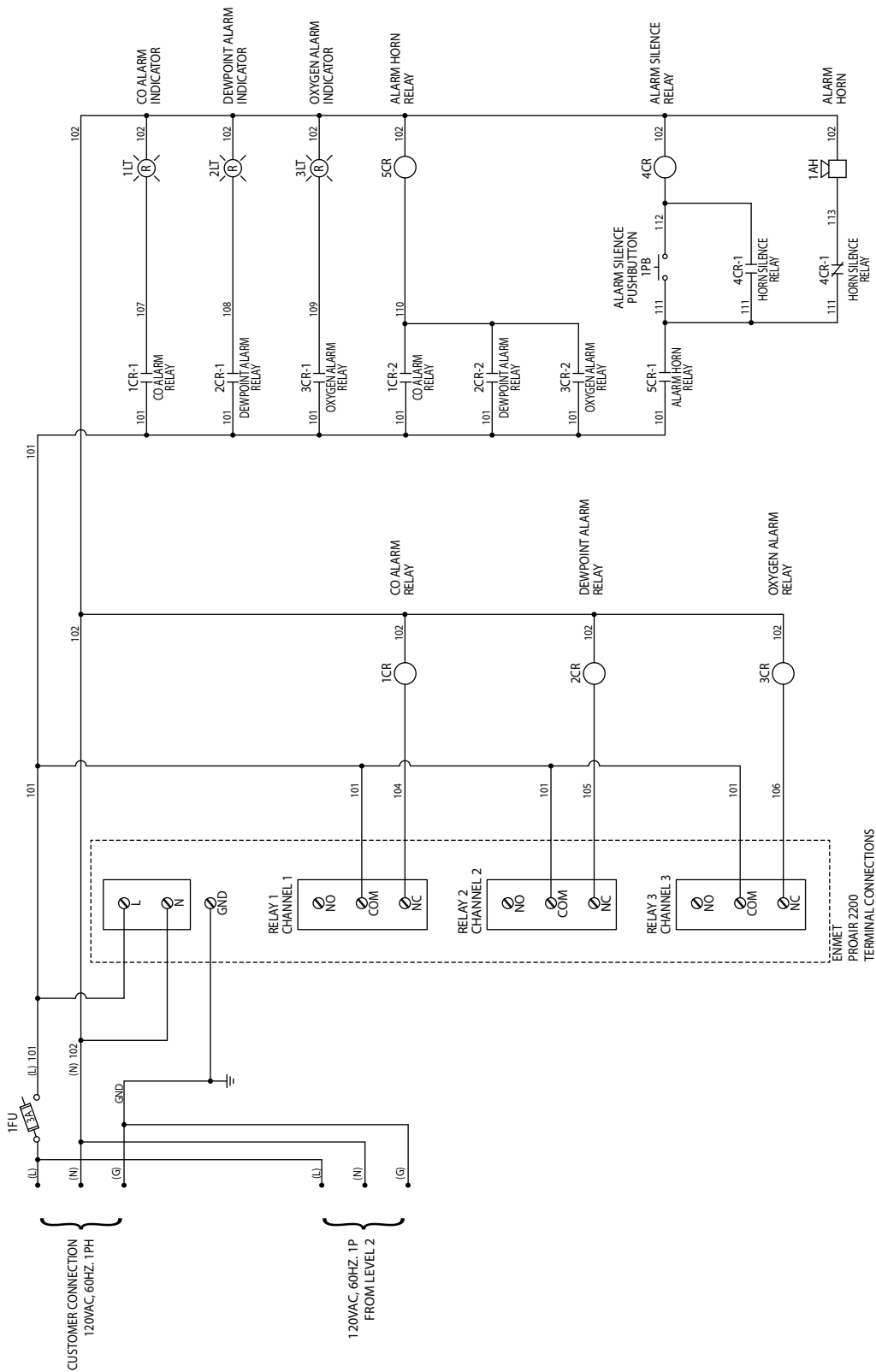

WARRANTY

The manufacturer warrants the product it manufactures, when properly installed, operated, applied, and maintained in accordance with procedures and recommendations outlined in manufacturer's instruction manuals, will be free from defects in material or workmanship for a period as specified below, provided such defect is discovered and brought to the manufacturer's attention within the aforesaid warranty period.

The manufacturer will repair or replace any product or part determined to be defective by the manufacturer within the warranty period, provided such defect occurred in normal service and not as a result of misuse, abuse, neglect or accident. Normal maintenance items requiring routine replacement are not warranted. The warranty covers parts and labor for the warranty period unless otherwise specified. Repair or replacement shall be made at the factory or the installation site, at the sole discretion of the manufacturer. Although not required for warranty consideration, it is recommended that the manufacturer be contacted prior to doing any warranty related service work. This action will provide guidance and instruction on the repair often times authorization to perform the work. NOTE: The manufacturer reserves the right to repair, replace in the case of warranty approval or reject the warranty claim once submitted.

Unauthorized service and use of unauthorized or pirated parts voids the warranty and any resulting charges or subsequent claim will not be paid. Products repaired or replaced under warranty shall be warranted for the unexpired portion of the warranty applying to the original product.

The foregoing is the exclusive remedy of any buyer of the manufacturer's product. The maximum damages liability of the manufacturer is the original purchase price of the product or part.

THE FOREGOING WARRANTY IS EXCLUSIVE AND IN LIEU OF ALL OTHER WARRANTIES, WHETHER WRITTEN, ORAL, OR STATUTORY, AND IS EXPRESSLY IN LIEU OF THE IMPLIED WARRANTY OF MERCHANTABILITY AND THE IMPLIED WARRANTY OF FITNESS FOR A PARTICULAR PURPOSE. THE MANUFACTURER SHALL NOT BE LIABLE FOR LOSS OR DAMAGE BY REASON OF STRICT LIABILITY IN TORT OR ITS NEGLIGENCE IN WHATEVER MANNER INCLUDING DESIGN, MANUFACTURE OR INSPECTION OF THE EQUIPMENT OR ITS FAILURE TO DISCOVER, REPORT, REPAIR, OR MODIFY LATENT DEFECTS INHERENT THEREIN. THE MANUFACTURER, HIS REPRESENTATIVE OR DISTRIBUTOR SHALL NOT BE LIABLE FOR LOSS OF USE OF THE PRODUCT OR OTHER INCIDENTAL OR CONSEQUENTIAL COSTS, EXPENSES, OR DAMAGES INCURRED BY THE BUYER, WHETHER ARISING FROM BREACH OF WARRANTY, NEGLIGENCE OR STRICT LIABILITY IN TORT.

Please note that the manufacturer's warranty for this product is intended to cover manufacturing defects and therefore does not cover consumable components (desiccants, filter elements, soft goods, standard maintenance kit wear items, etc.) or components that require periodic user adjustment (expansion valve, hot gas bypass valve or cooling water regulating valve) or calibration (dew point elements/sensors, gauge calibration, etc.).

Warranty Period

One (1) year parts and labor from the date of shipment from the manufacturer or the manufacturer's authorized distributor (not to exceed eighteen (18) months from the date of shipment from the factory, whichever occurs first).

**AUTHORIZATION FROM THE SERVICE DEPARTMENT IS NECESSARY BEFORE
MATERIAL IS RETURNED TO THE FACTORY OR IN-WARRANTY REPAIRS ARE MADE.**

SERVICE DEPARTMENT: (724) 746-1100

CATALITE® BREATHING
AIR PURIFIERS

CBA SERIES

SPXFLOW®

SPX FLOW, INC.

4647 S.W. 40th Avenue

Ocala, Florida 34474-5788 U.S.A.

P: (724) 745-1555

E: ft.dehydration.order.entry@spxflow.com

www.spxflow.com/hankison

Improvements and research are continuous at SPX FLOW, Inc.

Specifications may change without notice.

ISSUED 04/2022 Form No.: 3215426 Revision: L

COPYRIGHT ©2019 SPX FLOW, Inc.