

4

3

2

1

- REVISIONS -

ZONE	REV	DESCRIPTION	CHG BY	CHK BY	APP BY	REL BY	DATE
-	A	UPDATE PILOT AIR FILTER TO NGF STYLE.	NDM	SDM	DEH	SDM	07/02/14
-	B	310 PRE AND AFTERFILTERS WERE 308.	SDM	DEH	DEH	SDM	07/17/15

NOTES:

- THIS DRAWING, TOGETHER WITH P&ID AND SPECIFICATION SHEET, PROVIDES OPERATING CONDITIONS, SPECIFICATIONS, INSTALLATION, MOUNTING AND CONNECTION REQUIREMENTS.
- DESICCANT DRYER CHAMBERS ARE DESIGNED AND BUILT IN ACCORDANCE WITH THE CURRENT CODE AND ADDENDA OF SECTION VIII, DIV. I, OF THE A.S.M.E. CODE FOR UNFIRED PRESSURE VESSELS.
- ELECTRICAL CONSTRUCTION IS IN ACCORDANCE WITH THE NATIONAL ELECTRICAL CODE.
- ANCHOR BOLTS ARE TO PROJECT A MINIMUM OF 2" ABOVE THE FOUNDATION. ANCHOR BOLTS SHOULD BE INSTALLED IN SLEEVES TO ALLOW SOME ADJUSTMENT AT TIME OF INSTALLATION.
- EXTERNAL PIPING MUST BE RIGIDLY MOUNTED AND NOT SUPPORTED BY THIS UNIT.
- FOR MAINTENANCE PURPOSES, RECOMMENDED CLEARANCE AROUND UNIT IS 4 FEET [1220 MM].
- BREATHING AIR PURIFIERS CANNOT BE SUPPLIED WITH, OR REACTIVATED BY, ANY GAS OTHER THAN AIR. DO NOT PIPE PURGE EXHAUST TO A REMOTE LOCATION WITHOUT CONSULTING THE FACTORY.
- CUSTOMER SHOULD REQUEST A COPY OF QMS-013 IF PLANNING ON STORING UNIT LONG TERM BEFORE PLACING INTO SERVICE.

9. OPERATING CONDITIONS:

INLET AIR PRESSURE:

MAXIMUM:	150	PSIG	10.5	KGF/CM2
MINIMUM:	60	PSIG	4.2	KGF/CM2
DESIGN:	100	PSIG	7.0	KGF/CM2

INLET AIR TEMPERATURE:

MAXIMUM:	140	°F	60	°C
MINIMUM:	35	°F	1.7	°C
DESIGN:	100	°F	37.8	°C

AMBIENT AIR TEMPERATURE:

MAXIMUM:	120	°F	48.9	°C
MINIMUM:	35	°F	1.7	°C
DESIGN:	100	°F	37.8	°C

AIR FLOW:

INLET:	162	SCFM @ 100 PSIG & 100 °F
	275	M3/HR @ 7.0 KGF/CM2 & 37.8 °C
OUTLET:	135	SCFM @ 100 PSIG & 100 °F
	229	M3/HR @ 7.0 KGF/CM2 & 37.8 °C

10. SUPPLY POWER:

85-264 VAC, 1 PH, 47-63 HZ OR 11.5-28 VDC

11. AVAILABLE OPTIONS:

- L2 - ADVANCED CONTROLLER WITH:  
VACUUM FLUORESCENT TEXT DISPLAY  
PURGE SAVER(R) AUTOMATIC ENERGY SAVINGS  
HIGH INLET AIR TEMPERATURE ALARM  
LOW INLET AIR PRESSURE ALARM
- N7 - NEMA7 ELECTRICAL RATING
- CB - COPPER INSTRUMENT TUBING
- SS - STAINLESS STEEL INSTRUMENT TUBING, FITTINGS, AND GAUGES
- AZ1 - CO MONITOR
- AZ2 - CO & OXYGEN MONITOR
- AZ3 - CO & DEW POINT MONITOR
- AZ4 - CO, OXYGEN, & DEW POINT MONITOR
- 10 - SSPC-SP10 SANDBLAST & EPOXY PAINT

12. WEIGHTS: SHIPPING WEIGHT

	820	LBS. (APPROX.)
	373	KGS
OPERATING WEIGHT	820	LBS. (APPROX.)
	373	KGS

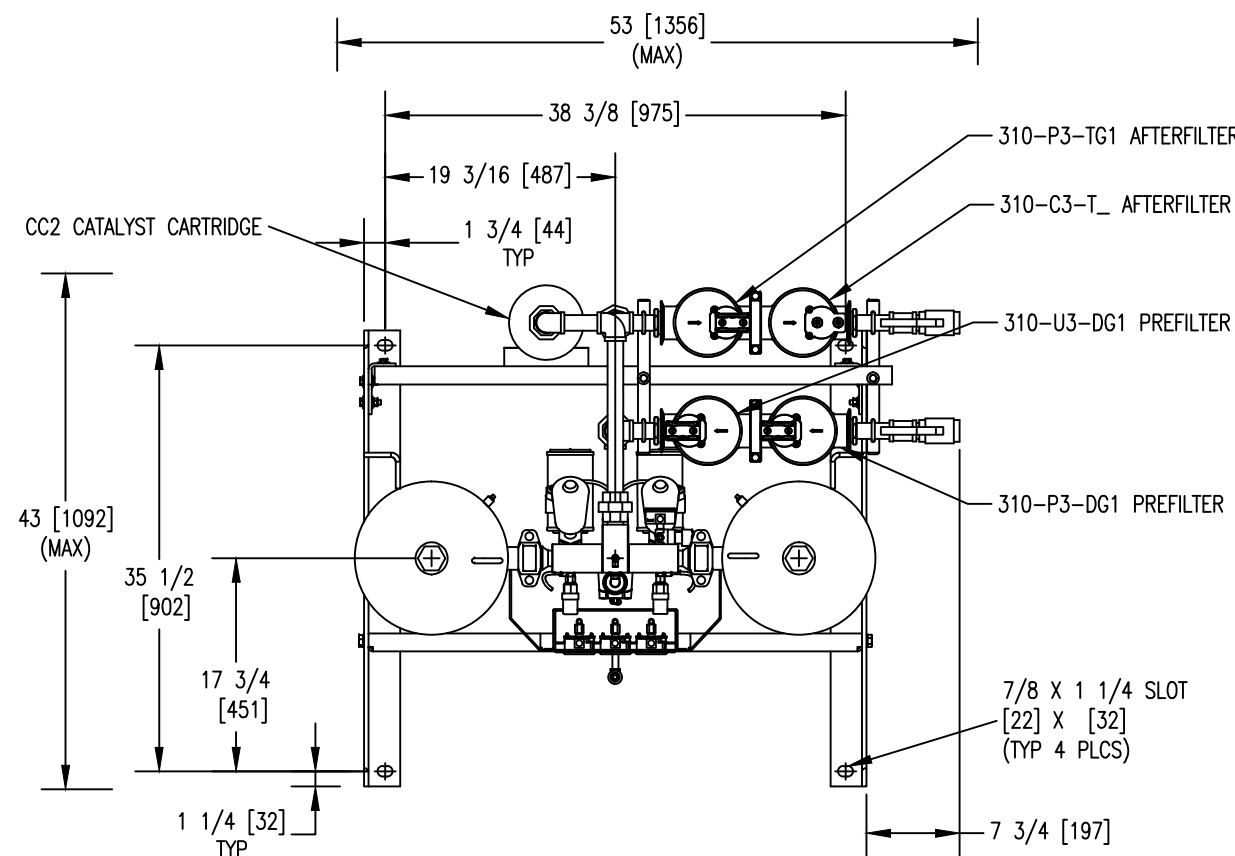

TOP VIEW

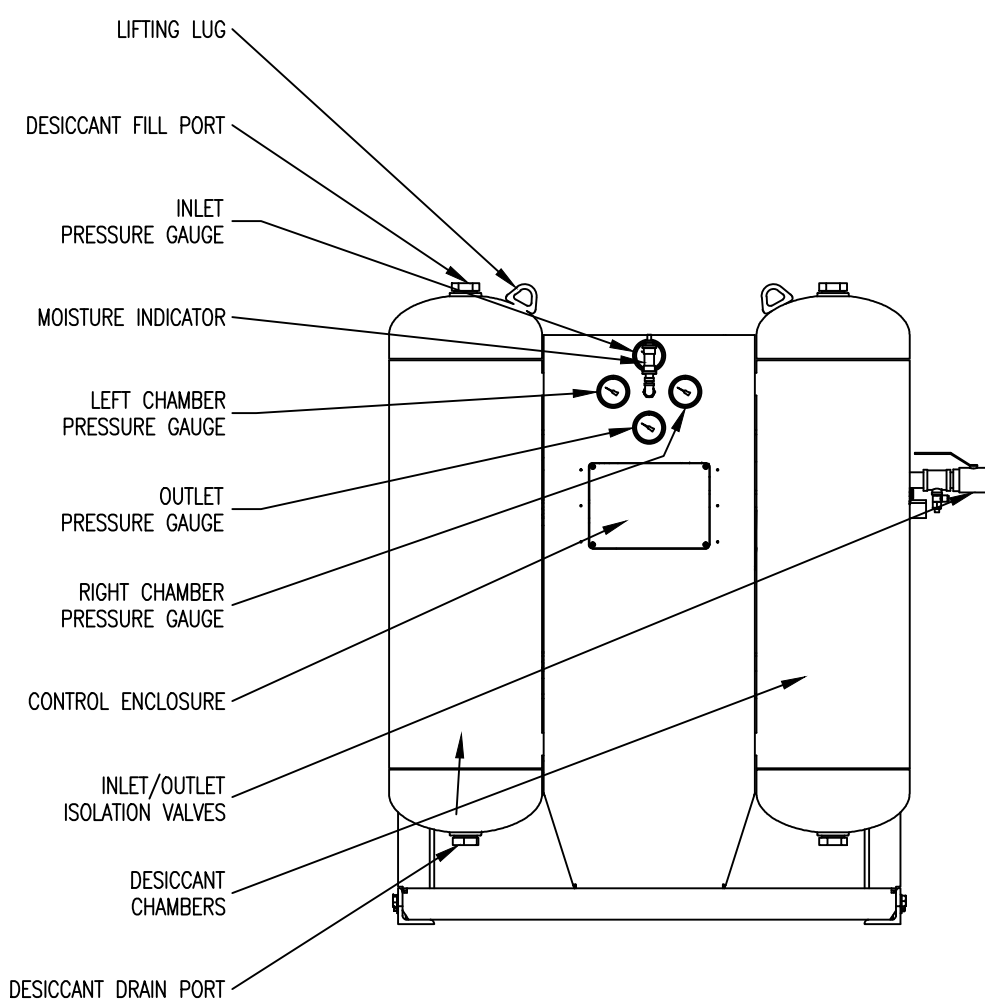

FRONT VIEW

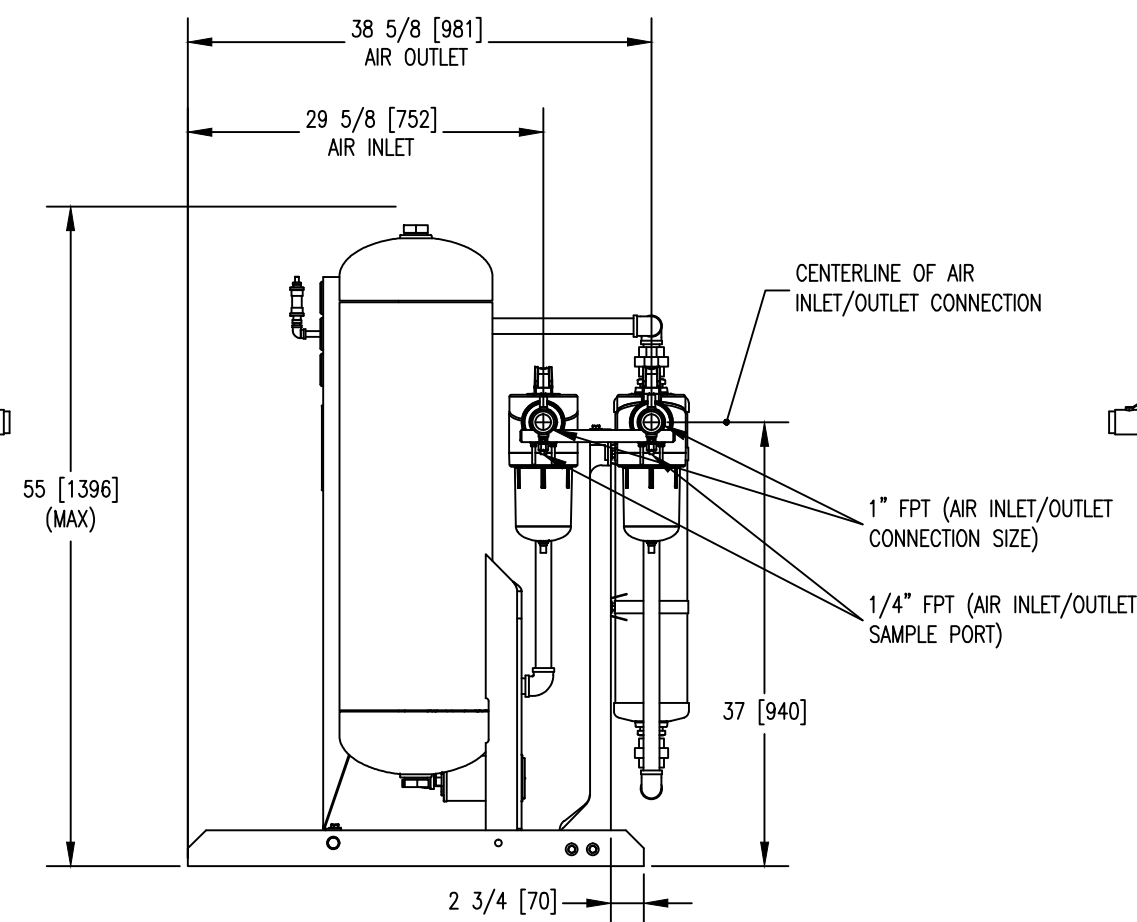

SIDE VIEW

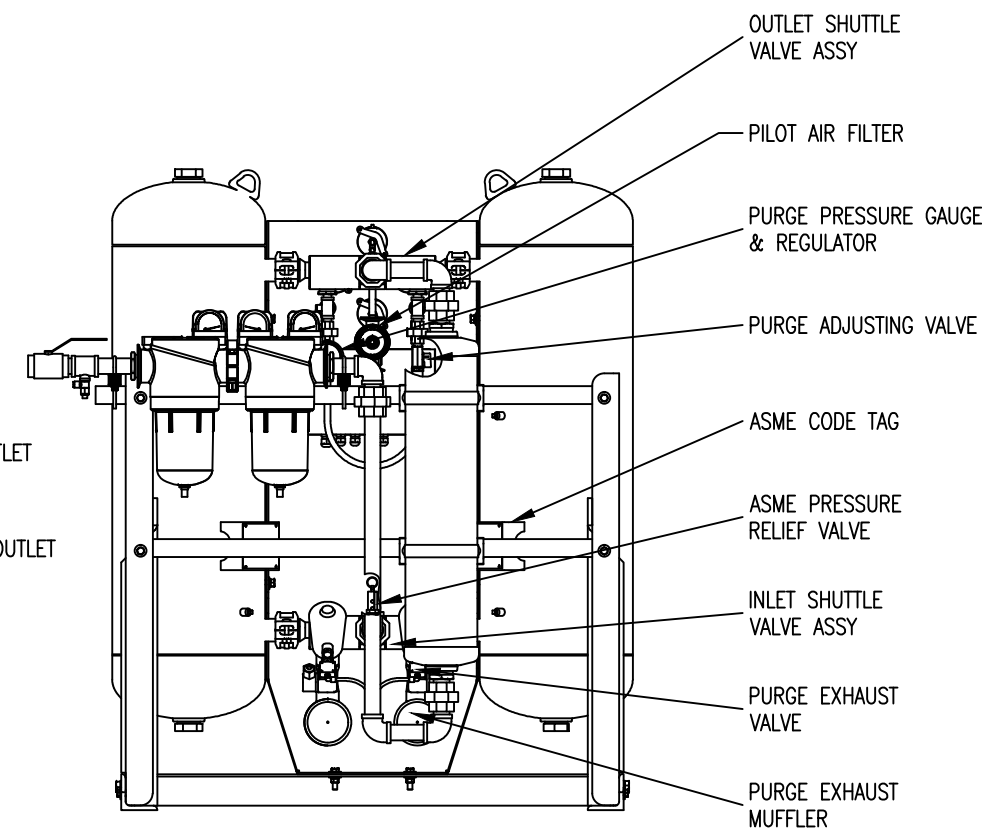

REAR VIEW

UNLESS OTHERWISE SPECIFIED:		NAME	DATE	UNAUTHORIZED USE, MANUFACTURE, OR REPRODUCTION IN WHOLE OR IN PART IS PROHIBITED. DRAWING DESIGN AND OTHER DISCLOSURES ARE PROPERTY OF:
DIMENSIONS ARE IN INCHES/MM		DWN BY	NDM 04/30/14	
SURFACE FINISH: N/A ✓		ENG BY	SDM 04/30/14	<b>Deltech</b> * DO NOT SCALE. USE DIMENSIONS ONLY *
TOL.	MM INCHES	CHK BY	SDM 04/30/14	
.X	- -	APP BY	SDM 04/30/14	
.XX	- -	REL BY	SDM 04/30/14	
.XXX	- -	MAT NO.	----	GENERAL ARRANGEMENT DM 135, BREATHING AIR PURIFIER, NGF
FRACT: ±1/2 ANG: ±2° SCALE: 1/16 WT: N/A		SIZE	C	
			DWG. NO.	0072208-135
			REV.	B 1/1

4

3

2

1